

SERVICE MANUAL

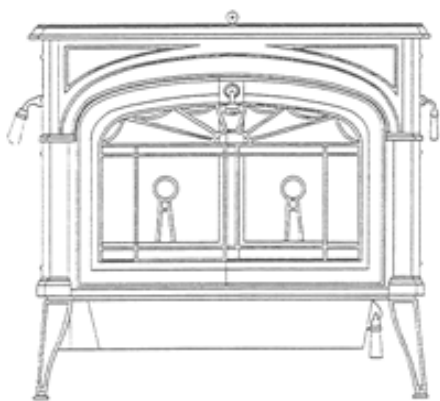

For the

VERMONT CASTINGS
1995 Encore

Model 2550

TABLE OF CONTENTS

History of Changes
Exploded View and Parts List
Service Procedures
Assembly and Disassembly
Gasketing
Appendix

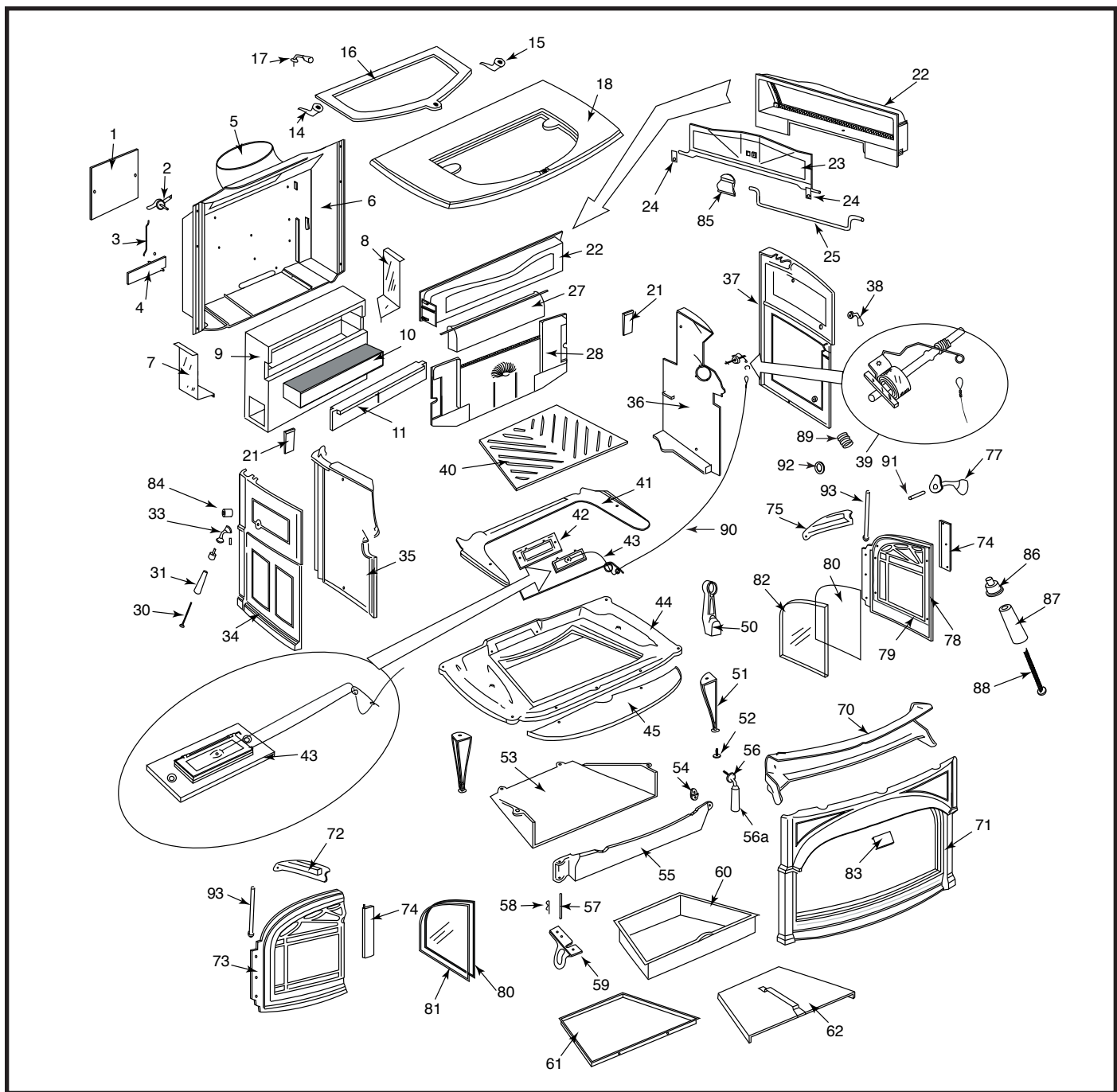

CFM Corporation reserves the right to make changes in design, materials, specifications, prices and discontinue colors and products at any time, without notice.

Encore Woodburning Stove

Model 2550

Item Description	Part Number
1. Secondary Air Cover Plate	1601492
2. Secondary Air Probe Assy	1601489
3. Secondary Air Link II, ENC	1601486
4. Secondary Air Flap	1601490
5. Flue Collar (8")	See Chart Pg. 35
6. Back	1308620

Item Description	Part Number
7. Left Heat Deflector	1608629
8. Right Heat Deflector	1608630
9. Refractory Assy w/Access Panel	1602510
10. Catalytic Combustor	1602505
11. Refractory Access Panel	1602511
14. Left Griddle Quad	1301807

Encore Woodburning Stove

Model 2550 (continued)

Item Description	Part Number
15. Right Griddle Quad	1301832
16. Griddle	1300797
17. Griddle Handle Assy	30002775
18. Top	See Chart Pg. 35
21. Wedge	1301810
22. Upper Fireback ¹	1308644
23. Damper ¹	1308631
24. Damper Tabs (3) ¹	1601488
25. Damper Rod ¹	1600851
27. Combustion Throat Hood	1301145
28. Lower Fireback	1308646
30. Damper Handle Screw 1/4-20 x 3/8" NT	1201294
31. Damper Handle, Wood	1600664
33. Steel Handle Stub	30002720
34. Left Side	See Chart Pg. 35
35. Left Air Plate (Inner side)	1308621
36. Right Air Plate (Inner side)	1308622
37. Right Side	See Chart Pg. 35
38. Thermostat Handle Assy	5004224
39. Thermostat Assy	5005470
40. Grate	1307434
41. Primary Air Tube Cover Plate	1308609
42. Primary Air Frame	1307411
Primary Air Valve Only	1301412
Primary Air Rod Only	1601493
43. Primary Air Regulatory System	5000337
44. Bottom	1308604
45. Ashlip	See Chart Pg. 35
50. Andiron (2)	1307419
51. Leg	See Chart Pg. 35
52. Leg Leveler	1201745
53. Ashdrop	1308603
54. Pawl Assembly Short Adjustment	30002362
55. Ashdoor	1308607

Item Description	Part Number
56. Ashdoor Handle (Wood)	1600663
57. Ashdoor Hinge Pin	1208608
58. Cotter Pin, Ashdoor	30001749
59. Ashdoor Hinge Support	1308605
60. Ashpan	1601025
61. Ashpan Bracket	1601039
62. Ashpan Cover	1601027
70. Airwash Manifold	1308615
71. Front II	See Chart Pg. 35
72. Left Door Air Manifold	1307403
73. Left Door	See Chart Pg. 35
74. Door Hinge Strip (2)	1308634
75. Right Door Air Manifold	1307404
77. Door Handle Assy w/Set Screw	30002721
78. Right Door II	See Chart Pg. 35
79. Door Gasket 5/16 Med. Density 6ND	1203588
80. Glass Gasket	1203556
81. Left Door Glass ²	1408630
82. Right Door Glass ²	1408629
83. Door Latch	1408628
84. Spacer 3/8 x 1-Z	1201779
85. Damper Ramp ¹	1301811
Socket Set Screw Adjuster	1200436
PH Flat Hd Screw	1200809
Hex Nuts	1203210
86. Handle Base Stub ³	30002714
87. Ceramic Handle 2.78 Lg ³	20006381
88. Handle Bolt ³	1201294
89. Friction Spring	1201846
90. Primary Air Cable w/Clips	5005471
91. 7/16-20 x 1 Socket Set Screw	1200334
92. Washer	1202471
93. Pin, Long, Door	30002727

1. Included in #5008649 upper fireback assembly.
2. Not interchangeable, due to a heat-reflective coating on the room side of the panels.
3. Included in #0004345 ceramic handle assembly.

Shell Enamel Parts - Encore Model 2550							
Part Name	Classic	Biscuit	Bordeaux	Chestnut Brown	Ebony	Midnight Blue	Vermont Green
Top	1306618	30003007	2328618	30003019	30003031	2378618	30003044
Front	1308635	30003004	2328635	30003016	30003028	2378635	30003041
Left Side	1308623	30003006	2328623	30003018	30003030	2378623	30003043
Right Side	1308619	30003005	2328619	30003017	30003029	2378619	30003042
Flue Collar	1304280	30003008	2324280	30003020	30003032	2374280	30003045
Ashlip	1307406	30003002	2377406	30003014	30003026	2377406	30003039
Left Door Sub Assy	5008648	30003012	30001144	30003024	30003037	30001345	30003049
Left Door	1308637	30003010	2328637	30003022	30003034	2378637	30003047
Right Door Sub Assy	5008647	30003011	30001143	30003023	30003036	30001344	30003048
Right Door	1308636	30003009	2328636	30003021	30003033	2378636	30003046
Single Leg	1307427	30003003	2327427	30003015	30003027	2377427	30003040

ENCORE 2550 HARDWARE

120-1745	¼ -20 x 1" Zinc Hex Head Leveller Bolt (1-in each of the four legs)	120-0334	7/16-20 x 1" Socket Set Screw (1-door insert for handle)
120-1337	¼ -20 x ⅜" Hex Head Cap Screw (2-left hinge plate, 2-right hinge plate)	120-0643	10-24 x 7/16" Black Socket Head Cap Screw (1-door handle stop)
120-2470	Washer, ¼ Plain Flat (2-ends to bottom, 2-upper firebk to back)	120-1392	¼ -20 x 2" Zinc Hex Head Cap Screw Gr 2 (1-air manifold to front)
120-8608	Pin, Hinge (1-ashdoor)	120-0992	10-24 x 1" Zinc Phillips Pan Head Screw (1-left manifold to door left screw, 2-right manifold to door)
30001749	Pin, Cotter (1-ashdoor hinge pin)	120-0991	10-24 x ¾" Zinc Phillips Pan Head Screw (1-left manifold to door right screw)
120-1376	¼ -20 x 1" Black Hex Head Cap Screw Gr 5 (2-right air plate, 2-left air plate)	120-2471	Washer, ¼" Flat .294 id x .620 od SS (primary air assembly)
30001794	¼ -20 x ⅜" Black Socket Head Cap Screw (1-primary air valve)	120-1373	¼ -20 x ⅜" SS Hex Head Cap Screw (2-andirons) {replaced 120-1340 - ½" June 05}
120-0896	¼ -20 x ⅜" Black Phillips Round Head Screw (2-primary air valve to bottom)	120-0881	¼ -20 x ¾" Phillips Flat Head Screw (1-top to front)
120-1374	¼ -20 X ¾" Hex Head Cap Screw (4-ashdrop to bottom, 3-hinge to ashdrop, 2-front to ends, 2-ends to bottom)	120-2473	Washer, Black ¼" Narrow Flat (2-ashpan bracket)
120-2474	Washer, Zinc ¼" Flat (3-ashdrop hinge, 4-ashdrop to bottom, 2-front to ends, 1-front to bottom, 2-left air plate, 2-right air plate, 2-top to ends, 4-front door hinge plates, 1-ashdoor adjust.)	120-0907	¼ -20 x 1" Black Phillips Round Head Screw (2-flue collar to top, 1-griddle handle)
120-0417	¼ -20 x ¼" Knl Cup Point Socket Set Screw (1-thermostat stub, 1-ashdoor pawl, 1-front door handle stub)	120-3329	Nut, ¼ -20 Plain Square (2-flue collar)
120-0563	5/16-16 x 5/16" Socket Set Screw (1-damper handle)	120-1396	¼ -20 x 1½" Zinc Hex Head Cap Screw Gr 5 (2-upper fireback to back)
120-0436	¼ -20 x 1" Oval Point Socket Set Screw (1-damper ramp adjuster)	120-1243	8-32 x 2" – Z Slot Round Head (1-thermostat knob)
120-0809	¼ -20 x 1" Phillips Flat Head Screw (1-damper ramp)	120-1986	Shim Ring, 18 Ga Nickel (1-secondary air flap)
120-3210	¼ -20 Hex Nut (2- top to ends, 2-damper ramp, 1-griddle handle stub, 1-ashdoor pawl, 1-front to bottom)	120-0980	10-24 x ¼" Phillips Pan Head Screw (3-glass clips right door, 4- glass clips left door, 2-secondary air assembly)
120-3290	⅜-16 Toplock Z Hex Head Jam Nut (1-ashdoor pawl)	120-4212	¼ -20 x 1¼" Threaded Rod (or 120-4214 – 1½") (2-top to ends)
120-1378	¼ -20 x 1¼" Hex Head Cap Screw (1-front to bottom)	120-1846	Friction Spring (1-primary air assembly)
120-1338	¼ -20 x ½" Hex Head Cap Screw (1-each griddle quad, 2-damper tabs ufb, 2-ashpan bracket, 1-damper rod stop)	120-0993	¼ -20 x ⅜" Phillips Pan Head Screw (2-secondary cover plate to back)
120-0482	¼ -20 x ½" Socket Flat Head Screw (2-ashlip)	120-2061	#10 x ¾" Black Phillips Pan Head SMS (3-flue collar to connector pipe)
120-1322	10-24 x ½" - Z inc Hex Head Cap Screw (4-heat shield taps in ashdrop)	120-1308	8-32 x 1" Zinc Slotted Pan Head Screw (1-griddle handle)
120-2488	Washer, Zinc ⅜" Flat (4-legs to bottom)	120-1310	¼ -20 x 3" Zinc Slotted Pan Head Screw (1-damper handle)
120-8610	⅜-16 x 1¼" Socket Head Allen Bolt (1-front left leg)	120-1294	¼ -20 x 3⅜" Zinc Slotted Pan Head Screw (1-fallaway handle)
120-1443	⅜-16 x 1¼" Zinc Hex Head Bolt (3-Leg Bolts)	120-4867	1/32" Stainless Steel Control Cable (3.7'–air thermostat)
120-0848	¼ -20 x 2" Black Phillips Flat Head Screw (2- side primary air cover plate to bottom)	120-4874	1/32" Oval Copper Sleeve (2–air thermostat control cable)
120-0998	10-24 x ½" Phillips Truss Head Screw (4-rear heat shield taps)	120-1899	5/16 Hole Plug (1-stove back)
120-1779	Spacer, 7/16" Narrow (1-damper rod)	120-1337	¼ -20 x ⅜" Hex Head Cap Screw (2-each door hinge strip)
120-2560	Washer, ⅜" Narrow (1-damper rod)	120-2907	Rivet, Pop 1/8 dia x 5/16 Grip (6-safety listing)
120-2423	Washer, Flat #10 SAE (2-under door latch)	160-0600	Handle Holder (1-right front leg)
		160-0547	Pin, Long (2-each door hinge)
		160-1488	Tab, Damper
		120-0983	10-24 x ⅜" Phillips Pan Head Screw (2-door latch to front)

HISTORY OF CHANGES

1995 DEFIANT ENCORE

Model 2550

This section covers the Defiant Encore Model 2550, built beginning in March, 1995.

In March 1995, *Vermont Castings* changed the Defiant Encore stove to simplify assembly and minimize enamel chipping.

- The visible parts of the front doors are now one casting instead of two. This ensures a good enamel colour match and minimizes chipping during assembly.
- The front door latch is lower than on earlier models, and catches on a steel fitting bolted to the stove front. This keeps the latch from chipping the enamel lip above the doors.
- The damper handle is relocated toward the back edge of the left stove side. Damper operation is reversed from the previous design; you pull the handle toward the front of the stove (counter-clockwise) to close the damper. The damper now has an adjusting screw, visible through the firebox and no linkage as it is a direct straight through design.

In March 1997, in order to avoid confusion with stove names, *Vermont Castings* changed the Defiant Encore stove name to ***Encore*** as the new Defiant 1910 was just introduced.

SERVICE PROCEDURES

1995 DEFIANT ENCORE

Model 2550

This section covers repairs and adjustments to the model 2550 Defiant Encore stoves built since March, 1995. Service procedures for this model are identical to those for the previous model 2190 Defiant Encore, except in three areas: *damper adjustment; the removal, re-gasketing, and replacement of the upper fireback / damper assembly, and adjustments to the front door.*

****Wear gloves, a dust mask and protective eyewear when servicing a stove. ****

Replacing the Refractory Package

1. Open the damper and remove the handle stub ("faucet").
2. Remove the andirons; one 7/16" hex head bolt each.
3. Remove the throat hood; swing its bottom edge forward and then slide hood to one side until the trailing end drops from its support. Take it out of the stove.
4. Remove the two wedges that hold the lower fireback in place.
5. Remove the lower fireback. Simply lift it out of the firebox.
6. Remove the left and right wear plates; two 7/16" hex head bolts each
7. Remove the upper fireback. Two hex head bolts hold it in place. The heads are on the outside of the stove back. Swing the right end of the upper fireback assembly forward and let it drop into the fireback.
8. Carefully pull the entire refractory package straight forward. Leave the steel heat exchangers in place in the left and right sides of the stove back.
9. Install the new refractory package. Replace the catalyst. Install the access panel.
10. Inspect, clean; or replace the fireback as needed.
11. Re-install the upper fireback assembly; fasten it in place with two ¼"-20 x 1-½" hex bolts.
12. Attach the handle and its 'faucet' to the handle rod with the Allen bolt, and test the damper for smooth action.
13. Re-install the left and right wear plates, with their two bolts each.

14. Re-install the lower fireback, and secure it with two wedges.
15. Replace the throat hood.
16. Re-install the andirons.

Replacing the Primary Air Cable

1. Remove the throat hood.
2. Remove the right wedge, between the right wear plate and the lower fireback.
3. Remove the right wear plate (bolts at top and bottom, 7/16" heads).
4. Remove the thermostat handle from the thermostat stem with an Allen wrench.
5. Pull the thermostat and stem assembly into the firebox. Be sure to hang onto the friction spring on the stem.
6. Remove the primary air frame and valve assembly. Pull the frame away from the stove bottom and to the right gently, to protect the primary air rod.
7. Detach the old cable from both ends. Be sure to keep the small clip that joins the upper end of the cable to the thermostat.
8. Fish the new cable through the primary air opening at the bottom of the right side of the firebox and through the primary air frame opening at the back bottom of the stove.
9. Attach both ends of the cable. Be sure the cable hangs properly from the rod on the thermostat stem, and passes under the stem. Be sure the friction spring is on the thermostat stem; push the stem through its hole in the stove side and re-attach the handle with the Allen bolt. Swing the handle back and forth to ensure that there's a bit of tension on the friction spring. If there's not enough tension on the spring to hold the thermostat assembly in place when you release it, loosen the Allen bolt on the handle stem and push the stem further out through the stove side, and re-attach the handle.
10. Clean the primary air frame and its mating surface of any old stove cement. Bolt the frame back into position, and test the thermostat action to be sure the valve nearly closes when the handle is swung fully to the rear.
11. Replace the right wear plate, with the two hex bolts, and replace the wedge that held the lower fireback in place.
12. Replace throat hood.

Adjusting the Damper

To adjust the damper to compensate for compression of the gasket, start by removing the griddle. Then:

1. Loosen the lock nut in the centre of the damper.
2. Use an Allen wrench to turn the pressure screw about one-half turn clockwise.
3. Test the damper's closing action. Do not over-tighten the screw, as this can cause binding when the parts expand under heat.
4. When the damper closes smoothly and snugly, tighten the lock nut and replace the griddle. (Fig. 1)

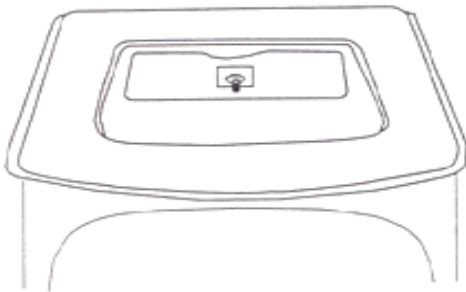

Fig. 1 Damper lock nut

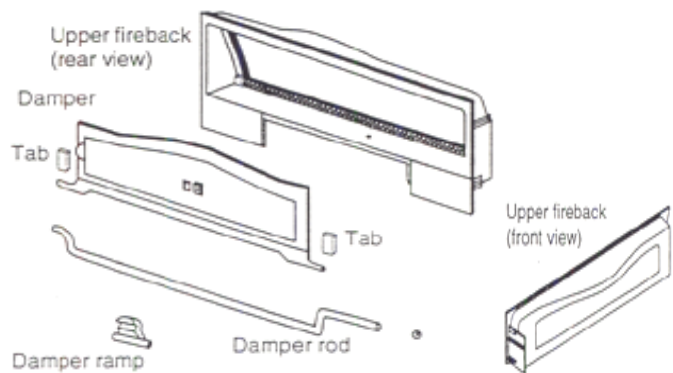

Fig.2 Damper components

Adjusting the Positions on the Front Doors

The doors are factory-set to ensure a good seal between them and the stove front. If necessary you can adjust their position slightly by loosening the bolts that hold them to the hinge strips on their edges. Loosen the bolts only enough to enable you to nudge them up or down; do this with the doors fully open to avoid hitting them against the front of the stove. Re-position the doors as necessary (being sure that the latch engages its catch properly) and then tighten the bolts. Check the fit with a slip of paper, and adjust the latch as needed.

DISASSEMBLY and ASSEMBLY

1995 DEFIANT ENCORE

Model 2550

Disassembly

1. Lift off the griddle and the front doors. Remove the ash pan and dump the ashes. The pan will be a convenient place to store hardware during disassembly.
2. Lift out the grate and loosen the bolts holding the andirons in place. Lift out the andirons.
3. Loosen the Allen bolts holding the thermostat and damper handles in place, and remove the handles.
4. Remove the throat hood by pulling its bottom edge forward till it clears the ribs on the lower fireback; then slide it to either side. It will fall into the firebox. Tap out the wedges holding the lower fireback in place. Let the fireback fall forward and lift it out.
5. Remove the two hex-head bolts holding the left and right inner walls ('wear plates') in place, and remove the wear plates. You may need to pry the forward edges of the plates to get them out of position. Be sure to pad the edges of the enameled stove front if you use a prying tool.
6. Remove the upper fireback assembly. It is held in place with two bolts going inward from the outer stove back. When the bolts are out, pry the right end of the assembly forward, and remove the assembly through the firebox.
7. Remove the flue collar. It is held by bolts and square nuts.
8. Remove the left and right stainless-steel heat deflectors from the back of the stove. Carefully slide the refractory chamber, including the combustor, forward into the firebox, and lift it out. Handle it carefully, as it's fragile.
9. Disconnect the thermostat cable from the thermostat rod, and remove the thermostat assembly by pulling it into the firebox. Be sure to keep the small coil spring that is on the main stem.
10. Remove the stove top. There are nuts on two vertical threaded stems at the left and right rear corners of the firebox, and one counter-sunk Phillips bolt in front, under the griddle handle notch. Since the top traps the stove back in place, either have a helper hold the back up while you remove the top, or put a rope or strap around the stove body before you remove the top. Then remove the back.

11. Remove the one side, then the other. They each have one bolt joining them to the stove front, and one bolt joining them to the bottom. When the hardware is out, break the cement seals and lift the parts off.
12. Remove the stove front. It has one bolt going through the middle of its bottom and into the stove bottom. The air manifold will come with the front when you remove it.
13. Remove the air tube cover. It has one bolt at each side, going downward into the stove bottom.
14. Flip the bottom assembly over, and remove the legs. The left front leg bolt head captures the ashdoor will then come off.
15. Remove the ashlip. It has two bolts going upward into the stove bottom.
16. Remove the ashdrop. It has four hex-head bolts joining it to the stove bottom.
17. Remove the air manifold from the stove front. It has one hex-head bolt at the top.
18. Examine all castings for cracks, chips, or distortions. Repair or replace as needed. Repair all old gasket material. Use a cold chisel or an old screwdriver to remove old stove cement from cement channels and mating surfaces.
19. Remove the damper from the upper fireback, and remove the gasket. Examine the damper tabs and replace as needed.

ASSEMBLY

Gasketing

If new parts need to be gasketed, or old parts re-gasketed, **do all of the gasketing before starting to assemble the stove.**

Parts which need to be gasketed include:

Part	Gasket Size	Gasket Part No.
Left front door	5/16" x 58"	120-3588
Right front door	5/16" x 42"	120-3588
Front door (each glass)	3/16" x 36"	120-3556
Ashdoor	5/16" x 42"	120-3588
Griddle	5/16" x 44"	120-3668
Flue collar	5/16" x 40"	120-3591
Upper fireback (damper opening)	5/16" x 42"	120-3588
Left wear plate	3/8" x 52"	120-3589
Right wear plate	3/8" x 60"	120-3589
Primary air valve	Preformed Gasket	120-3518
Lower fireback	5/16" x 36"	120-3588

Instructions and illustrations are given at the end of this section of the manual.

Cementing

Prepare parts which will need to be cemented before starting to assemble the stove, but **do not apply cement until just before installing the parts.**

Cementing instructions are given below. Illustrations showing where to apply cement are given as needed in the assembly instructions.

Prepare parts carefully so that new cement makes a tight seal between the parts to be joined. The channels and edges to be cemented must be free of old cement and dust.

Use high quality stove cement.

New cement hardens quickly when exposed to air.

- Clean and prepare parts ahead of time.
- Apply cement just before putting the parts in place.

****Work in an area where there is plenty of light, and a level work surface. Wear gloves and protective eyewear.****

If the parts to be cemented are new, start with step 2. If old parts are to be re-cemented, they will need to be cleaned. Start with step 1.

1. Clean old cement from the channels and edges to be joined. Use a hammer and cold chisel, or screwdriver to remove old cement. Use a wire brush to finish cleaning the channels and edges. Vacuum the channels to remove dust.
2. Wipe the surfaces to be cemented with a damp cloth. Apply a generous bead of cement in the channel. Excess cement may squeeze out of the joint.

Excess cement which shows on the outside of the unit may be removed with a damp sponge. Clean up the excess promptly.

Excess cement on the inside of the unit will not usually be a problem. If clean-up is necessary, instructions will be given.

3. Join the two parts. Move the parts as little as possible after they have been put together.

Assembly

You will need at least 6 tubes of stove cement to re-assemble a Defiant Encore. Cut the tips of the tubes so you can apply an unbroken bead of cement to the cement channels and mating surfaces.

1. Place the stove bottom upside-down. Put a generous bead of cement around the top edge of the ashdrop (**Fig. 3**). Attach the ashdrop to the bottom with four hex bolts.

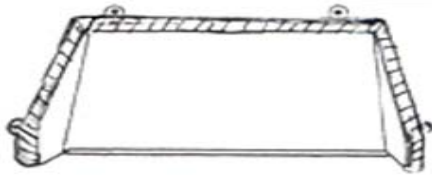
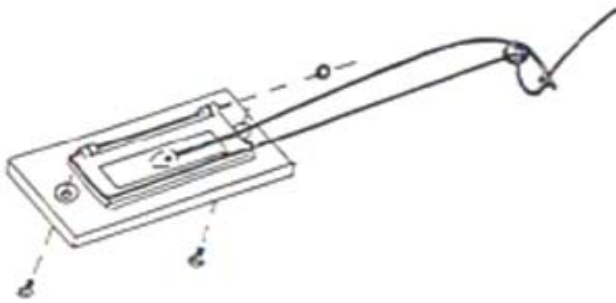

Fig. 3 Ash Drop

Thread a leg leveler into each leg, and install the legs. Put the handle holder on the right front leg. Use an Allen bolt to secure the left front leg, to accept the ashdoor hinge.

2. Attach the ashdoor bottom hinge to the bottom of the ashdrop. Attach the ashlip to the bottom with two countersunk bolts. Attach the ashdoor by running its hinge pin through the left end of the ashdoor and into the socket head of the left front leg's Allen bolt. Run the cotter pin through the hinge pin to hold it in place.
3. Assemble the primary air valve assembly. Put the air frame facedown with the drilled bosses up. Thread the primary air rod through the hole in the bottom of the air valve and just start it into the left top (hinge) hole of the frame. Put the valve and rod in the



frame so that the air rod holes align. Push the air rod from left to right through the aligned holes and secure the rod in the frame with a 1/8" friction clip (**Fig. 4**). Turn the assembly over and install the socket head cap (adjusting) screw, 1/4-20 x 3/18", in the centre of the air valve, finger tight.

4. Install the primary air valve assembly on the stove bottom with the hinged side down (**Fig. 5**). Secure the assembly with two Phillips round head bolts, 1/4-20 x 5/8".

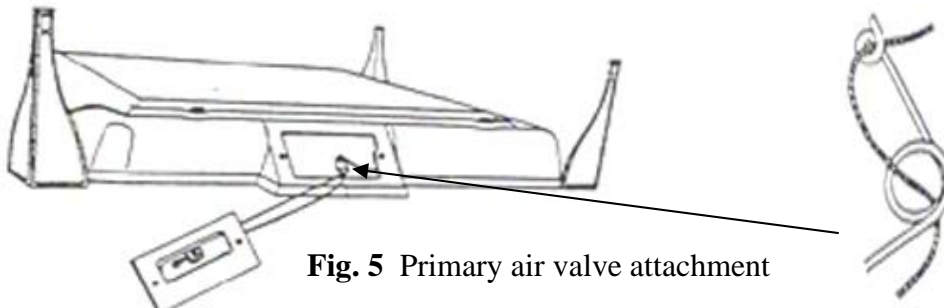

Fig. 5 Primary air valve attachment

- Turn the stove bottom over onto its legs. Thread the running end of the thermostat cable down through the small hole and up through the large hole in the air rod.

Pull the running end of the cable over to the valve and thread it through the small hole in the centre of the valve. Pull 6" of cable outside the valve. Tighten the set screw finger tight (**Fig. 4 and 5**). Pass the thermostat cable through the right-hand gap between the air cover and the stove bottom. Bolt the primary air cover to the stove bottom.

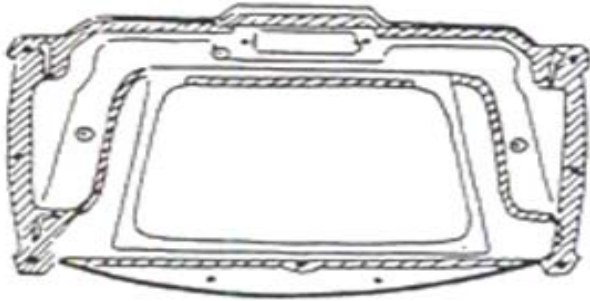

Fig. 6 Bottom

- Cement all the channels, flanges and mating surfaces indicated in **Fig. 6**. Keep the cement off the thermostat cable.
- Put the stove front in its cemented channel on the stove bottom and secure with one $\frac{1}{4}$ -20 x 1" hex bolt.

- Install threaded stems in the tapped holes in the left and right back edges of the stove front. Cement all mating surfaces on the stove front as shown in **Fig. 7**. Put the air manifold in position on the inside of the stove front and secure with one hex bolt, $\frac{1}{4}$ -20 x 2" long.

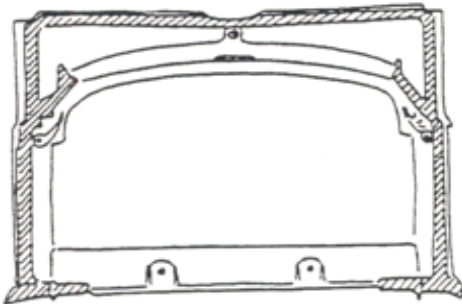

Fig. 7 Front

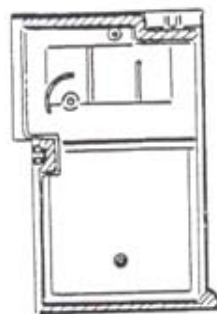

Fig. 8 Left End



Fig. 9 Right End

- Cement the channels and mating surfaces on the left stove end as shown in **Fig. 8**. Put the left stove end into its mating channels in the stove front, swing the back of the end onto the stove bottom so that the hole in the inside bottom flange of the end aligns with the tapped hole in the stove bottom. Secure the end to the bottom with a $\frac{1}{4}$ -20 x $\frac{3}{4}$ " hex bolt and a washer.
- Cement the mating surfaces as shown in **Fig. 9**. Put the right stove end into its mating channel on the stove front, swing the back of the end onto the stove bottom so that the hole in the inside bottom flange of the end aligns with the tapped hole in the stove bottom. Secure the end to the bottom with a $\frac{1}{4}$ -20 x $\frac{3}{4}$ " hex bolt and a washer.

11. Mount the front to the stove bottom and to the stove ends. The threaded stems on the back edges of the stove front pass through clevises on the front edges of the stove ends, and are secured with hex nuts and washers. The front attaches to the stove bottom with a ¼-20 hex bolt and washer.
12. Put a 1-½" threaded stems into the two holes at the rear corners of the underside of the stove top. Apply stove cement to the grooves around the underside of the stove top, and to the rear edges of the stove sides (**Fig. 10**).

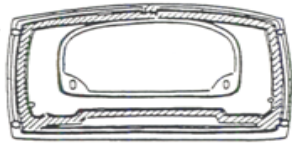

Fig. 10 Top (underside)

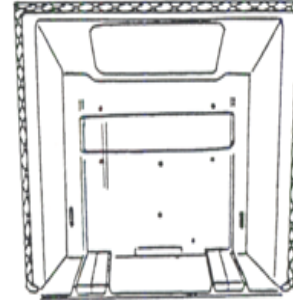

Fig. 11 Back (inside view)

13. Apply cement to the grooves in the back – **Fig. 11**. Put the stove back into position. It will be easiest to have a helper hold it in place temporarily. Install the stove top, which captures the top edge of the back, and secure it with washers and hex nuts on the two threaded stems at the rear corners. Secure the front of the stove top to the stove front with one Phillips-head bolt, ¼-20 x 1", passing downward through the notch where the griddle handle fits.
14. Install the refractory chamber. It should fit snugly against the outer back of the stove, and downward against ribs on the bottom of the back panel. Install the left and right heat deflectors in the heat-exchange passages to the left and right of the refractory chamber.
15. Assemble the upper fireback assembly. This will include the damper, the torsion bar, and the upper fireback, along with damper tabs.
16. Install the upper fireback assembly. Put the left end into position first, then lift the right end and swing it out to meet the back of the stove. Secure it with washers and two ¼-20 x 1-½" hex bolts going in from the outside.
17. Attach the damper 'faucet' to the damper rod and tighten the set screw.
18. Install the Left Inner Side; it secures with two ¼-20 bolts. Re-test the damper system for smooth operation.

19. Install the thermostat. Be sure that the friction spring is on the stem, between the outer end and 'ears' pressed onto the stem, and that the wire stem coming off the bi-metal coil passes over the stem and toward the front of the stove. Loosely attach the thermostat handle to the stem, on the outside of the stove. Attach the thermostat cable to the end of the wire stem, and check the system for smooth operation. The primary air valve should close to within ¼" of the valve frame with the thermostat cable swung fully to the rear. Be sure that the friction spring provides enough friction to keep the valve open when the handle is positioned fully forward.
20. When the thermostat is working well, install the right inner side. It secures with two ¼-20 hex bolts and washers.
21. Put the catalytic combustor into the refractory package, ensuring that it is fully to the rear. Install the refractory access cover.
22. Install the lower fireback. Ribs on its back side channel secondary air to the combustor. Be sure the panel is fully down in its bottom channel. Secure it with a wedge on each end. Install the throat hood; put one of its end pins on a support on the lower edge of the upper fireback, and slide the hood toward that side until the other end pin is within the other support, then slide it back until it is centered on the lower fireback. Let the lower edge of the hood rest against the lower fireback.
23. Install the slotted grate. It simply rests in place, with the wider side of the slots downward, toward the ashdrop. Bolt the andirons into place.

24. Install the secondary probe assembly see **Fig. 12** for positioning guidance. If necessary, loosen the lock nuts on the probe shaft and adjust the position of the tab on the thermostat coil so that it is at 4 'o' clock as you face it from the rear, with the mounting tab at 12 'o' clock.

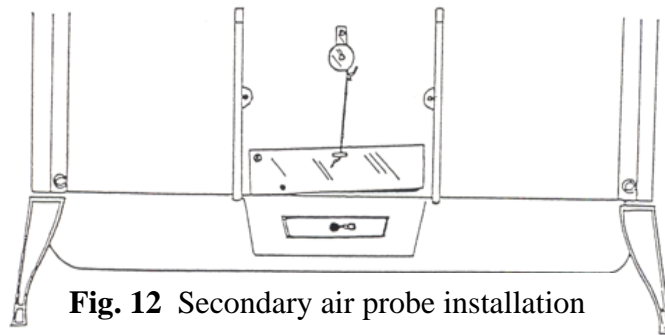

Fig. 12 Secondary air probe installation

Insert the double-bent end of the thermostat air link through the hole in the tab end of the thermostat coil. Insert the single-bent end through the hole in the tab on the secondary air flap. Insert the probe through the hole in the stove back and secure it with a Phillips pan-head bolt, #10 – 24 x ¼". Secure the secondary air flap to the stove back with a similar bolt and a shim ring. Tighten the bolt holding the air flap until it is snug, then back it off ¼ turn. Insure that the flap moves freely up and down and that the flap rests at or near the closed position.

25. Install the secondary air cover plate. Secure it with two Phillips pan-head bolts, ¼-20 x 3/8".

26. Assemble and install the ashdoor. Screw the socket, button head bolt into the stepped side of the latch pawl (**Fig. 13**). Thread the hex nut onto the end of the bolt and tighten it finger tight against the flat side of the pawl. Slide the ashdoor handle shaft through its hole in the ashdoor. Slide the pawl onto the shaft so that the pawl offset is opposite the handle curve. Ensure that the pawl is against the door and that the handle turns without binding. Tighten the set screw in the pawl. Thread the jam nut onto the handle shaft and tighten it against the pawl. Position the ashdoor between the bottom hinge panel and the bottom of the stove; slide the ashdoor hinge pin upward through the bottom hinge, through the ashdoor, and into the socket of the Allen bolt holding the left leg to the stove bottom. Secure the hinge pin with a clevis pin just above the bottom hinge.

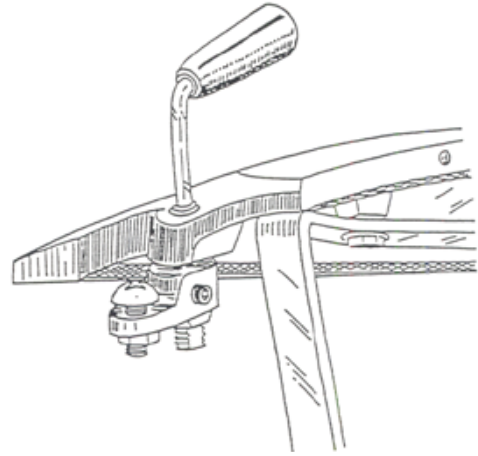

Fig. 13 Ashdoor handle assembly

27. Test the door seal with a 'paper test', closing the door on a slip of paper and latching the door. The easier it is to pull the paper out, the looser the seal is at that spot. Adjust the latch as needed to ensure a good seal all around the door. If latch adjustments don't provide a good seal, replace the gasket with a thicker one, or remove it and apply a thin bead of stove cement to the bottom of the channel. Let this bead dry before you replace the gasket before it hardens, resulting in a poor seal.
28. Install the ashpan bracket on the ashdoor. Secure it with two $\frac{1}{4}$ -20 x $\frac{1}{2}$ " hex bolts and washers. Close and open the ashdoor. If the bracket hits the ashlip, adjust it as needed by tapping the bracket or twisting it. Insert the ashpan and re-test the ashdoor operation to ensure that there's no impact between the pan and anything else.
29. Paint the front doors, and then assemble them. Mask the gasket channels to avoid over-spray. Re-gasket them if necessary. Put them facedown on a flat surface, and install the glass. Check the edges of the glass for markings indicating the coated side of the panes; the coated sides go outward, away from the fire. Install the air manifolds.
30. Install the flue collar. It mounts with two Phillips round-head bolts, and nuts inside the stove.
31. Prepare the stove for painting. Clean up any excess cement with a putty knife, and mask the handles, the secondary air cover, and the safety plate. It's better to apply two light coats of paint than one heavy coat.
32. Install and adjust the front doors. The latch assembly adjusts with one turn of the handle faucet. Remove the small Allen socket-head bolt from the right door to allow the faucet to spin fully. Use the paper test here to ensure that the doors provide a snug seal all around, including where the right door overlaps the left door.

33. Install the griddle. Gently tap the perimeter of the griddle to seat it against the gasket.
34. If you have replaced any major iron panels, tell the customer to re-cure the stove with a series of four small fires, each hotter and longer than the last, to acclimate the iron to the stresses of heat.

GASKETING

If you are replacing gaskets as part of standard maintenance, refer to the Maintenance Section of the **Owner's Guide**.

If you are replacing all gaskets as while re-building a firebox, follow the instructions given below. Prepare parts carefully. Channels must be free of old gasketing, cement and paint, and free of dust.

Use high quality gasket cement.

****Work in an area where there is plenty of light and a level work surface. Wear gloves and protective eyewear.****

If you will install gaskets on clean, new parts, start with step 3. If you are going to re-gasket old parts, they will need to be cleaned. Start with step 1.

1. Remove old gaskets. If the ends of the gasket meet, note where the joint is.
2. Clean the channels. Use a hammer and cold chisel or screwdriver to remove old cement. Vacuum the channel to remove dust.
3. Choose the correct size gasket. Cut it to the right length, allowing an inch extra for trimming.
4. Wipe the channel to be gasketed with a damp cloth. Place an unbroken 1/8" bead of cement in the channel. Avoid using too much cement. The cement should not saturate the gasket, just hold it in place.
5. Starting with one end, lightly press the gasket into the cemented channel. Trim excess gasket with shears or side cutting pliers. Do not leave any ragged ends. If the ends of the gasket meet, there should be no gaps or overlaps. Do not stretch the gasket as this will make it too thin. A thin gasket may not make a good seal.
6. If possible, place the gasketed part against the surface it will meet. This will seat the gasket evenly.
7. Clean any excess cement that has squeezed out around the gasket.

8. After installing new gaskets, it may be necessary to make adjustments on the damper or load door. Refer to your **Owner's Guide**.

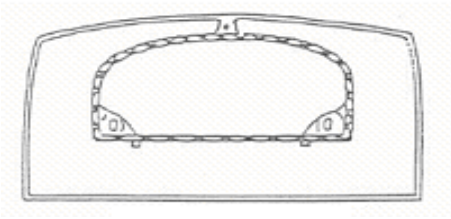

Fig. 14 Top
5/16" x 44" Griddle Gasket

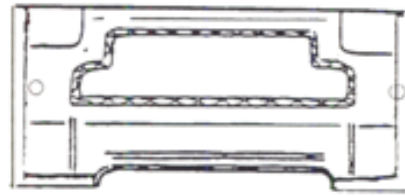

Fig. 15 Upper Fireback
5/16" x 42" for damper opening

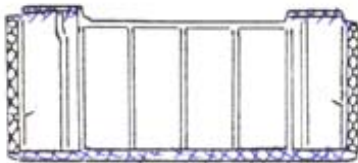

Fig. 16 Lower Fireback
5/16" x 36" Fiberglass

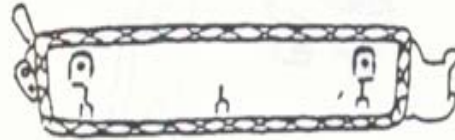

Fig. 17 Ashdoor
5/16" x 42" Fiberglass

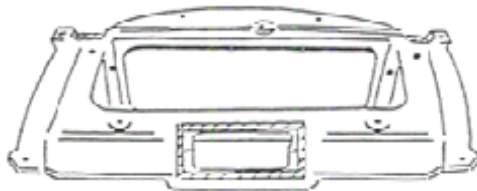

Fig. 18 Bottom
Formed Gasket for Primary Air Valve

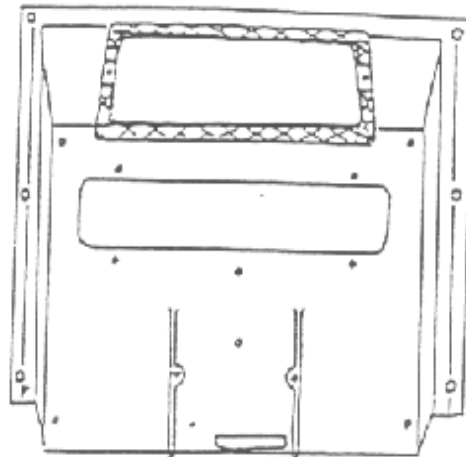

Fig. 19 Back (flue collar to stove back)
5/16" x 30" Adhesive Backed Gasket

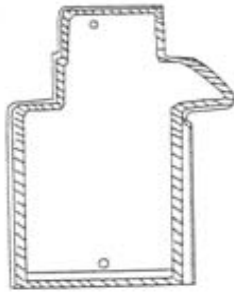

Fig. 20 Left Inner Side (outside view)
3/8" x 54" Fiberglass

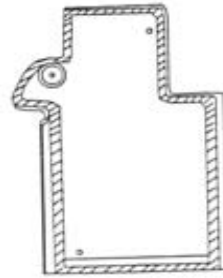

Fig. 21 Right Inner side (outside view)
3/8" x 58" Fiberglass

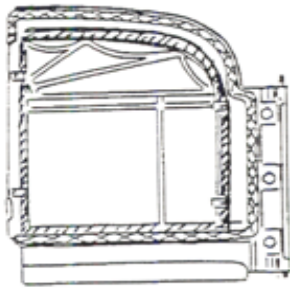

Fig. 22 Left Door (inside view)
3/16" x 36" Fiberglass to Seal Glass
5/16" x 58" Fiberglass to Seal Door



Fig. 23 Left Door (outside view)
Gasket which wraps around from the back.

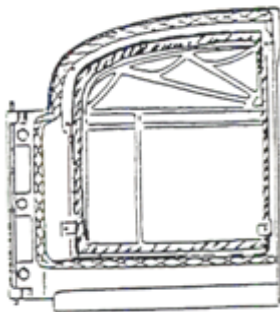

Fig. 24 Right Door (inside view)
3/16" x 36" Fiberglass to Seal Glass
5/16" x 42" Fiberglass to Seal Door

Gasketing the Damper/Upper Fireback

1. Remove the throat hood from the fireback by swinging it upward and then sliding it to either side (**Fig. 25**).

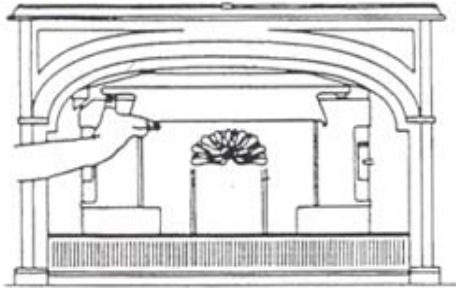

Fig. 25 Removing the Throat Hood

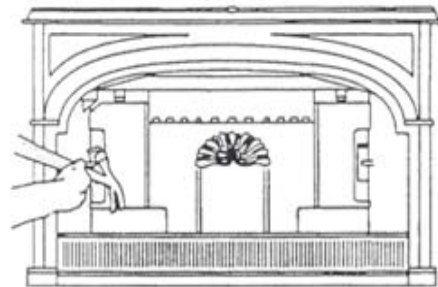
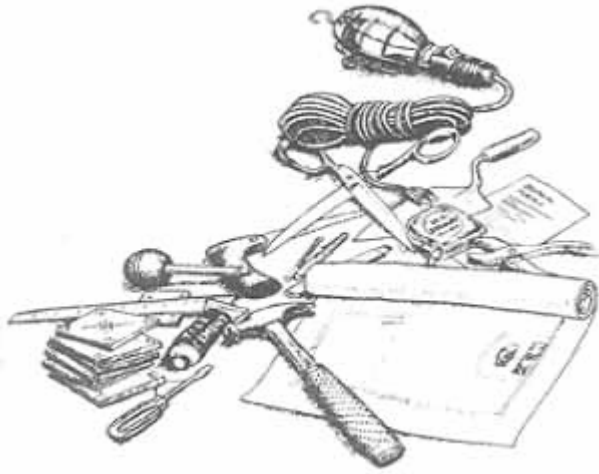

Fig. 26 Removing the Wedges

2. Remove the left and right wedges that hold the lower fireback in place, and remove the lower fireback (**Fig. 26**)
3. Remove the left and right inner walls – each has a hex-head bolt at top and bottom. These inner walls are gasketed so you're not breaking a cement seal here. You may need to pry these walls out with a screwdriver going into notches at their forward edges--if the stove is enameled, protect the surfaces near the notch.
4. Remove the Allen bolt from the damper handle, and slide the handle off.
5. Remove a hex-head bolt from each side of the stove's outer back, near the top.
6. Remove the upper fireback assembly through the firebox. You may need to use a large screwdriver to pry it loose from the stove back. As you face the stove, remove the right-hand end first.
7. Remove the damper from the upper fireback by removing bolted tabs at each end.
8. Remove the original gasketing by pulling it out of its channel, and then clean the channel with a wire brush.
9. Apply a narrow bead of stove cement to the bottom of the gasket groove, and lay the gasketing into the channel. Do not stretch or bunch the gasket unless you need to compensate for parts that have changed shape slightly. Close the damper and lock it closed; check the seal with a slip of paper to ensure tightness. Leave the damper closed for a few hours if you can, to ensure that the cement sets up well.
10. Work in reverse order to re-install the upper fireback; apply cement to the backs of the ends of the upper fireback before re-installing.



APPENDIX #1

YEARLY MAINTENANCE SUGGESTIONS

The 2550 Defiant Encore is a sophisticated combustion machine, and regular “fine tuning” will give you the full benefits of its operating potential.

GENERAL CHECKLIST

- Inspect the chimney for blockage such as squirrels, nests, branches, etc.
- Have a chimney sweep inspect and clean the chimney if necessary.
- Inspect the connector pipe for wear and replace if necessary.
- Make sure each length of connector pipe, if single wall, is joined by three screws.
- Inspect the stove gaskets for wear using the “Dollar Bill Test” and replace as necessary.
- Remove any surface rust and repaint any heat shields or chimney connectors.

INSPECT THE CATALYTIC COMBUSTOR

Fly ash can accumulate on top of the combustor. If sufficient quantity accumulates, it can block the flow of gases through it and cause restriction and back-puffing.

- Remove the throat hood from the stove by swinging it upward and sliding it to either side.
- Remove the left and right wedges that hold the lower fireback in place, and remove the lower fireback by pulling forward from the top first.
- Gently pry off the refractory catalyst cover with a flat blade screwdriver. Remember the proper alignment for reinstalling the cover.
- Visually inspect the catalyst for fly ash using a small mirror. It is not necessary to remove the catalyst for this purpose.
- If the catalyst appears coated with fly ash, carefully remove the catalytic combustor. The catalyst element is contained within a stainless steel jacket (can). You may have to grasp the element with two flat bladed screwdrivers at the element ends to draw the element from the stove. If the honeycomb is clogged, take the element outside for cleaning. Blow gently through the honeycomb.

Inspect the element. Although small hairline cracks will not affect performance, the element should essentially be intact. If elements are broken or missing, the catalyst should be replaced. If the catalyst is in good shape and all the fly ash has been removed, re-install the combustor in the stove by sliding it into the opening, making sure that it is resting on the refractory shelf. Gently reinstall the catalyst cover. The refractory cover should be flush with the other refractory surfaces.

CLEAN THE SECONDARY AIR PASSAGE

Fly ash can also accumulate in the secondary air passageway. Once a year it is a good idea to vacuum out this opening.

- The secondary air cover is located immediately below the catalyst access panel. Remove the two Phillips pan head screws holding the secondary air cover to the back of the stove.
- Push the secondary air flap up to the open position with your finger and place a vacuum nozzle at the opening.
- Replace the cover.

CHECK THE GASKET SEALS ON THE DAMPER AND ASH PAN DOOR

In addition to the gaskets on the front doors and griddle, the Encore has seals on the damper and the ash pan door that are important for proper stove performance.

- Test the ash pan door seal by placing pieces of note paper or dollar bills at three locations across both the bottom and top of the door. Close and latch the door. If the paper is easily moved or pulled out, the door is not properly sealed and the gasket should be replaced using 3/8" fiberglass gasket.
- To replace the gasket, first pull out the old gasket. Clean the channel with a wire brush. Next, lay the new gasket in place and trim to the correct length. Place a 1/8" bead of gasket cement in the channels and press the trimmed gasket into place. Close the door. Seat the gasket in the door by pushing in hard against the door (a rubber mallet may be used). Open the door and remove any excess cement that has squeezed out around the gasket.
- The door gasketing will compress within the first few weeks, so you will need to readjust the latch. To do this, loosen the hex lock nut with an open end wrench and back off the striker screw. Tighten the screw until the door seals securely and the latch still operates. Then tighten the hex lock nut.

CHECK THE DAMPER

The Encore's damper is designed to snap into a locked position. When closing the damper, push the handle past the point at which you feel resistance until it snaps into the locked position.

- Place several pieces of note paper along the top and bottom of the damper and lock the damper.
- As with the ash pan door, if the pieces can be easily pulled out (very little resistance), replace the 5/16" gasket.
- This is most easily done through the flue collar opening (the flue collar may also be removed). Pull out the old gasket and clean the channel.
- Place a thin bead of gasket cement in the channel.
- Cut a length of gasket to size and press it into the channel.
- Allow the cement to harden for 24 hours before firing the stove.

CLEAN THE GLASS

The Encore's glass is designed to stay free of carbon deposits, even under low fire conditions. However, periodic cleaning is necessary to prevent permanent etching of the glass with fly ash or carbon. Use a commercial wood stove glass cleaner supplied by your dealer or you may wish to make your own cleaning paste. Take a damp cloth and dip it into the fine grey ash in the ash pan. Wipe the glass with this and a paste will form and continue until the glass is cleaned. Buff with a clean cloth.