

# WinterWarm Fireplace Insert or System

Homeowner's  
Installation and  
Operating Manual

For Use in North America

**SAFETY NOTICE: IF THIS APPLIANCE IS NOT PROPERLY INSTALLED, OPERATED AND MAINTAINED, A HOUSE FIRE MAY RESULT. TO REDUCE THE RISK OF FIRE, FOLLOW THE INSTALLATION INSTRUCTIONS. FAILURE TO FOLLOW INSTRUCTIONS MAY RESULT IN PROPERTY DAMAGE, BODILY INJURY OR EVEN DEATH. CONTACT LOCAL BUILDING OFFICIALS ABOUT RESTRICTIONS AND INSTALLATION INSPECTION REQUIREMENTS IN YOUR AREA.**



We recommend that our woodburning hearth products be installed and serviced by professionals who are certified in the U.S. by the National Fireplace Institute® (NFI) as NFI Woodburning Specialists or who are certified in Canada by Wood Energy Technical Training (WETT).



**Do Not Discard This Manual: Retain for Future Use**

# Introduction

Thank you for purchasing a Vermont Castings' WinterWarm, an efficient fireplace carefully engineered to bring you the latest in wood combustion principles and modern foundry technology.

The WinterWarm masonry Fireplace Insert turns a traditional masonry fireplace into a powerful heater; the WinterWarm Fireplace System combines an insulated metal cabinet with the Fireplace Insert so that it may be installed in close-clearance situations where no masonry fireplace and chimney exists.

Whichever you have purchased, you can count on years of comfortable heating and pleasureable fire viewing if you treat it properly and operate it according to the directions in this owner's guide.

The WinterWarm Fireplace Insert, and the WinterWarm Fireplace System that utilizes the WinterWarm Fireplace Insert, are listed by Underwriter's Laboratories of Canada, and are in compliance with the standards set forth by the Federal Environmental Protection Agency, 40 CFR Part 60.532(b), as stated on the permanent label attached to each appliance.

This manual describes the installation and operation of the WinterWarm catalytic-equipped wood heater. This heater meets the U.S. Environmental Protection Agency's emission limits for wood heaters sold after July 1, 1990. Under specific test conditions this heater has been shown to deliver heat at a rate ranging from 10,300 to 30,000 Btu's/hr.

For more complete details on WinterWarm performance and specifications, please refer to page 3.

The WinterWarm is designed, tested and listed for burning wood. Do not burn other fuels.

We recommend that you hire a professional installer certified by Wood Energy Technical Training (WETT) to install your WinterWarm, or to advise you on the installation should you attempt to install it yourself.

Please read the appropriate sections of this manual before you install and use your WinterWarm. For information on the installation of a WinterWarm into a masonry fireplace, read Sections III and V. To learn how to install the WinterWarm and its Cabinet that make up the fireplace system, read Sections IV and V. For information on Operation and Maintenance of the WinterWarm, read Sections I and II.

Failure to follow instructions may result in property damage, bodily injury or even death.

## Save These Instructions For Future Reference

### Table of Contents

Introduction.....	2
Specifications .....	3
Operation.....	4
Maintenance.....	9
Preparing a Masonry Chimney .....	16
Installing the Fireplace System Cabinet .....	21
Appendices.....	38

#### Before you begin, here's a timesaving tip on using this manual.

- To learn how to operate and maintain the WinterWarm, read Sections I and II.
- To install a WinterWarm Fireplace Insert into a masonry fireplace, read Sections III and V.
- To install a WinterWarm Fireplace System, read Sections IV and V.

**Proposition 65 Warning:** Fuels used in gas, wood-burning or oil fired appliances, and the products of combustion of such fuels, contain chemicals known to the State of California to cause cancer, birth defects and other reproductive harm.  
California Health & Safety Code Sec. 25249.6

# Specifications

## WinterWarm

Range of heat output\* ..... 10,300 - 30,000 BTU/hr  
 Maximum heat output\*\* .....50,000 BTU/hr  
 Area heated\*\*\* ..... Up to 1500 sq. ft. (140sq. m)  
 Size of wood splits ..... 20-24" (508-610 mm)  
 Fuel Capacity ..... 40lbs. (18 kg)  
 Loading .....Front  
 Flue size ..... 8" (203 mm)  
 Fireplace Insert weight ..... 475lbs. (216 kg)  
 Fireplace System weight ..... 840lbs. (380 kg)  
 Primary Air Control .....Manual/thermostatic  
 Secondary Air Control .....Self-regulating  
 Glass panel ..... High-temperature ceramic  
 Flue exit position ..... Top  
 Blower rating .....106cfm. (115V, 60Hz)

\*Under specific test conditions used during EPA emissions standard testing.

\*\*This value can vary depending on how the unit is operated, and the type and moisture content of the fuel used. Figure shown is based on maximum fuel consumption obtained under laboratory conditions and on average efficiencies.

\*\*\*These values are based on operation in building-code conforming homes under typical winter climate conditions in New England. If your home is of nonstandard construction (e.g. unusually well insulated, not insulated, built under ground, etc.) or if you live in a more severe or more temperate climate, these figures may not apply. Since so many variables affect performance, consult your Vermont Castings' Authorized Dealer to determine realistic expectations for your home.

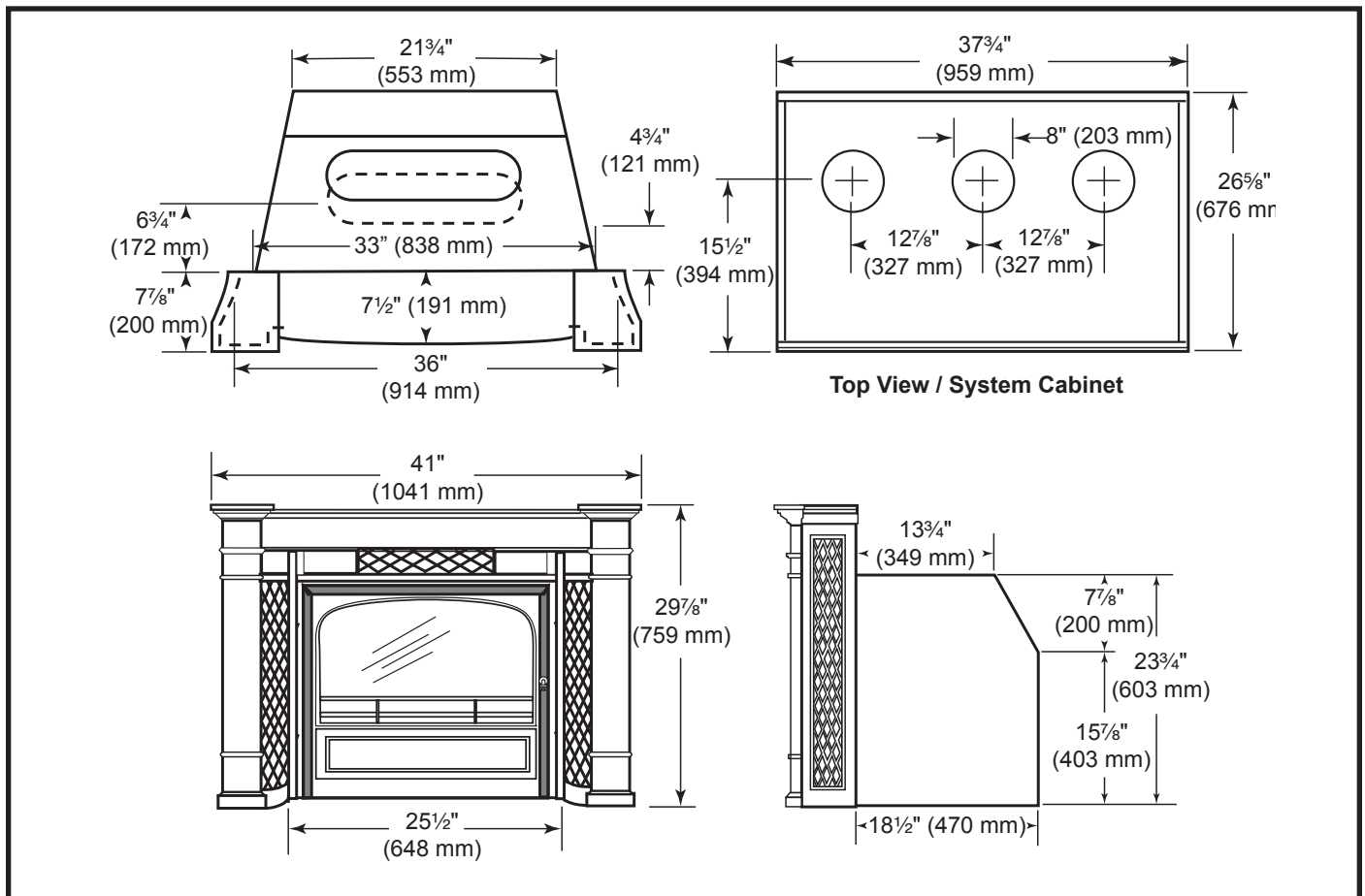


Fig. 1 WinterWarm dimensions.

## Section I Operation

### Your WinterWarm's Controls and What They Do

Three controls regulate the performance of your WinterWarm: A primary air control supplies oxygen for the fire, a damper directs air flow within the fireplace, and a variable-speed fan control, or rheostat, regulates the warm air flow into the room. (Fig. 2)

#### Primary Air Control

A single air control regulates the amount of heat the fire will produce and how long it will burn.

The **primary air control** is located above the upper left corner of the door. It is the top-most of the two brass-capped controls located there (the brass knob on the bottom regulates the fan), and is the primary source of air for starting, maintaining, and reviving the fire.

Generally, more air entering the stove makes the fire burn hotter and faster, while less air prolongs the burn.

The WinterWarm's air supply is open to the maximum when the control lever is moved to the left, and closed when moved to the far right. It may be set anywhere between the two extremes, however, depending on the amount of heat desired.

To complement the manual setting of the air control, the WinterWarm has an internal automatic thermostat that ensures an even delivery of heat at the manual setting you select.

#### The Damper

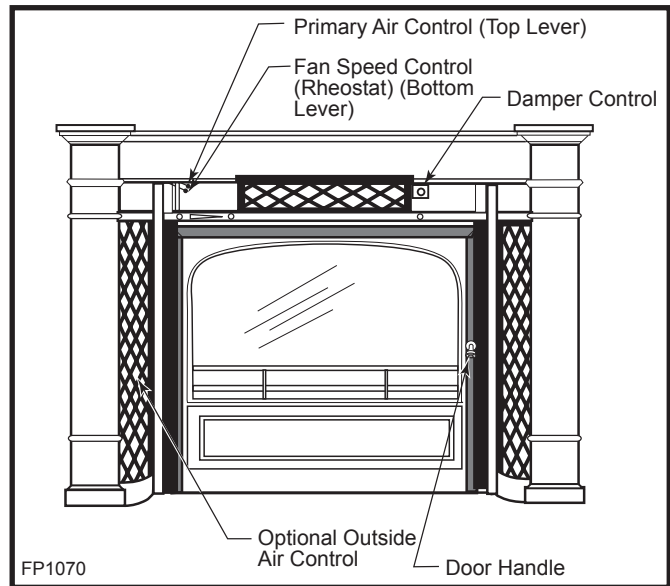
**The damper directs air flow within the fireplace.**

The **damper** is operated by moving the lever located above the upper right corner of the door. It has two positions: Open, to start or revive the fire (Fig. 3); and closed (Fig. 4), for normal operation. The damper is open when the lever is to the far left, and closed when to the far right. There are no intermediate settings for damper position.

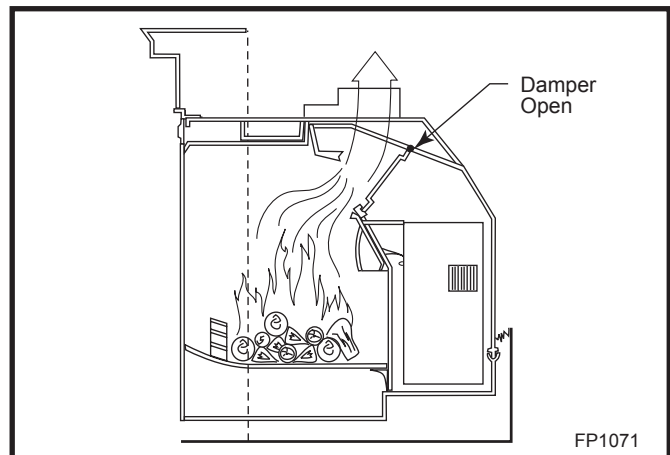
When the damper is closed, the front door automatically locks to prevent the door being inadvertently opened when the fireplace is in its catalytic mode. This could cause smoke to spill into the room.

To open the damper, lift up on the lever and move it to the far left. The lock will disengage, allowing you to open the front door.

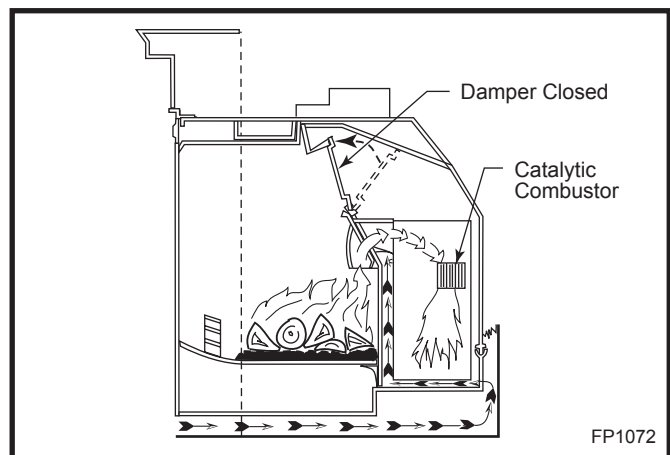
To close the damper, move the lever to the right, continuing past the resistance to lock the damper in position. (The door handle must be positioned vertically before the lock mechanism will engage.)



**Fig. 2** All WinterWarm controls are located conveniently on the front.



**Fig. 3** The damper is open; Smoke is vented directly to the chimney.



**Fig. 4** Damper is closed: Smoke is channelled through the catalytic combustor where much of it can be burned.

## The Fans

Two fans deliver a steady stream of warm air.

Heated air from your WinterWarm is forced into the room by two internal fans. The control for the fans is below the brass primary air control knob, just above the upper left corner of the door. (Fig. 5)

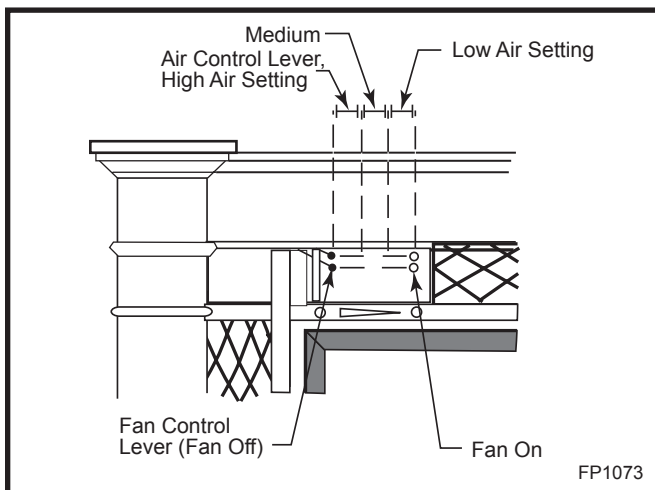
“Off” is to the far left.

“High” is just to the right of “Off.”

“Low” is to the far right.

Variable adjustment of the fans is possible with any setting between “high” and “low.”

For best results, coordinate fan speed with the setting of your thermostat. For example, when the thermostat lever is set at “low,” also set the fans at “low.” With the thermostat set for maximum heat, set the fans at “high.”



**Fig. 5** Variable settings for both the fans and the air control are possible between the two extreme settings.

## Burn Only High-Quality Wood

The WinterWarm is designed to burn natural wood only; do not burn fuels other than that for which it was designed.

You'll enjoy the best results when burning wood that has been adequately air-dried. Avoid burning “green” wood that has not been properly seasoned.

The best hardwood fuels include oak, maple, beech, ash, and hickory that has been split, stacked, and air-dried outside under cover for at least one year.

For areas that do not have a supply of hardwood, commonly burned softwoods include tamarack, yellow pine, white pine, Eastern red cedar, fir, and redwood. These too should be properly dried. Your WinterWarm will accept wood up to 24” (610mm). Longer wood pieces work better than short ones.

Wood should be stored under cover to maintain dryness, and should be dried at least six months for optimum heating and fire-viewing performance. Even for short-term storage, however, keep wood a safe distance from the heater and keep it out of the areas around the heater used for refueling and ash removal.

## Use the Air Control Settings that Work Best for You

No single air control setting will fit every situation. Each installation will differ depending on the quality of the fuel, the amount of heat desired, and how long you wish the fire to burn.

The control setting also depends on your particular installation's “draft,” or the force that moves air from the stove up through the chimney. Draft is affected by such things as the length, type, and location of the chimney, local geography, nearby obstructions, and other factors.

Too much draft may cause excessive temperatures in the WinterWarm, and could even damage the combustor. On the other hand, too little draft can cause backpuffing into the room and/or the “plugging” of the chimney or combustor.

How do you know if your draft is excessively high or low? Symptoms of too much draft include an uncontrollable burn or a glowing-red part of the WinterWarm front. A sign of inadequate draft is smoke leaking into the room through the stove or chimney connector joints, low heat, and dirty glass.

In some newer homes that are well-insulated and weather-tight, poor draft may result from insufficient air in the house. In such instances, an open window near the stove on the windward side of the house will provide the fresh air needed.

Another option for getting more combustion air to the stove is to duct air directly from the outside to the stove. In fact, in some areas provisions for outside combustion air are required in all new construction.

Your WinterWarm is designed so that it is possible to incorporate outside air for combustion. Directions for installing the optional outside air duct may be found beginning with Step 4 on Page 31.

When first using the stove, keep track of the settings of the air controls. You will quickly find that a specific setting will give you a fixed amount of heat. It may take a week or two to determine the amount of heat and the length of burn you should expect from various settings.

Most installations do not require a large amount of combustion air, especially if adequate draft is available. **Do not for any reason attempt to increase the firing of your heater by altering the air control adjustment range outlined in these directions.**



Use the following air control settings as a starting point to help determine the best settings for your installation. Each is described as a fraction of the total distance the lever may be moved from right to left.

#### WinterWarm Control Settings

<u>Burn Rate</u>	<u>Primary Air Control</u>
Low	From far right to 1/3 the distance to left
Medium	From 1/3 to 2/3 the distance to left
High	From 2/3 the distance to left to far left

### How To Build a Wood Fire and Keep It Going

A WinterWarm leaves the factory with the combustor installed.

In the United States, it is against the law to operate this wood heater in a manner inconsistent with operating instructions in this manual, or if the catalytic combustor is deactivated or removed.

### High-Efficiency Wood Burning with Catalytic Combustion

The components of the catalytic combustion system in your WinterWarm work together to produce optimum conditions for secondary combustion.

When the damper is closed, smoke is directed through the **catalytic element**, which causes ignition of smoke at temperatures of 500-600°F (260-315°C), half the temperature normally required for unaided secondary combustion.

The catalytic element is a ceramic “honeycomb” coated with the catalytic material. The element is located in the **secondary combustion chamber**, molded from a special **high-temperature insulating refractory** material. The design of the chamber provides the correct environment necessary for secondary combustion of the fuel (smoke).

Catalytic combustion is activated by closing the damper, thereby exposing the smoke to the combustor.

Closing the stove damper may also reduce the draft, so to avoid putting out the fire or deactivating the combustor, close the damper only when a fire is well-established. When starting a fire, wait until the fire is well established and there is an ember bed of at least 3-4” (76 - 102mm) before closing the damper.

Never kindle a fire with colored paper or paper that has colored ink or a glossy surface, and never burn treated wood, garbage, solvents, or trash. All of these may poison the catalyst and prevent it from operating properly. Never burn cardboard or loose paper except

for kindling purposes. Never burn coal; doing so can produce soot or large flakes of char or fly ash that can coat the combustor and cause smoke to spill into the room. Coal smoke also can poison the catalyst so that it won't operate properly.

In general, the fire must be sufficiently well-established to ensure that catalytic activity is initiated. When first starting a fire, a medium- to high- firing rate must be maintained for at least twenty minutes. This ensures that the stove, catalyst, and fuel are all stabilized at the proper operating temperatures.

Even though it is possible for the fire to get quite hot within a few minutes after a fire is started, the combustor may stop working or the fire may go out if the fire is allowed to die down immediately as a result of the damper being closed. Once the combustor starts working, heat generated by burning the smoke will keep it working.

To determine whether the combustor is operating, observe the amount of smoke leaving the chimney when the damper is activated and when it is not. This procedure is described on Page 12.

### Starting and Maintaining a Wood Fire

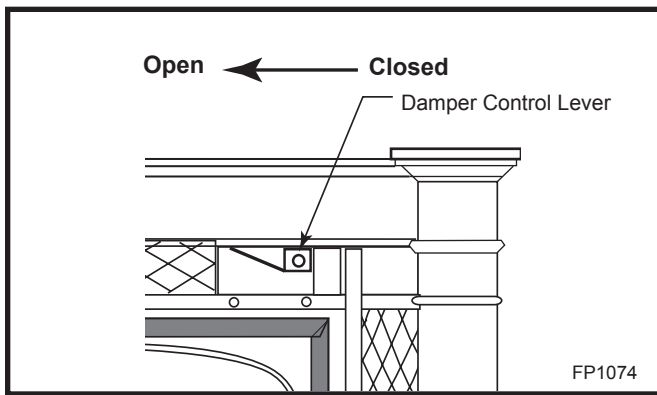
**Burn solid wood fuel only in the WinterWarm, and burn it directly on the grate. Do not elevate the fuel. Do not burn coal or other fuels.**

Cast iron is a superior material for solid fuel stoves but it must be treated with respect. It is extremely strong, but can be broken with a sharp blow from a hammer or from the thermal shock of rapid and extreme temperature changes.

The cast plates expand and contract with changes in temperature. Minimize thermal stress by allowing the plates to adjust gradually during an initial break-in fire by following Steps 1-3 below.

Always be certain that the damper is open when starting a fire or when refueling. This rule is easy to remember, as the WinterWarm's integrated door/damper interlock design does not permit opening the door unless the damper is already open. To open the damper, lift up on the lever and move it to the left. (Fig. 6)

**WARNING: Operate your WinterWarm only with the door fully closed and either the glass panel or spark screen in place. If the door is left partially open, gas and flame may be drawn out of the fireplace opening, creating risks of both fire and smoke.**



**Fig. 10** When the damper is closed, the front door automatically locks to prevent opening while a fire is burning.

1. Open the stove damper, and open the primary air control fully.
2. Lay some crumpled newspapers on the bottom grate. Place on the paper six or eight pieces of dry, finely-split kindling. On the kindling lay two or three larger sticks of split dry wood approximately 1-2" (25-51mm).

**Do not use chemicals or fluids to start the fire. Do not burn garbage or flammable fluids such as gasoline, naphtha, or engine oil.**

Also, never use gasoline-type lantern fuel, kerosene, charcoal lighter fluid, or similar liquids to start or "freshen up" a fire in this heater. Keep all such liquids well away from the heater while it is in use.

3. Light the newspaper and close the door. Gradually build up the fire by adding a few 3-5" (76 - 127mm) diameter splits.

If this is your initial break-in fire, let the fire burn brightly, but not to excess. Control the fire's intensity by adjusting the air control lever. After an hour or so stop adding wood so that the fire dies out gradually.

For ongoing operation after the initial break-in, continue to add a few sticks at a time of a progressively larger size. Be sure to keep the fuel load behind the front grate bar at all times. Continue until you have a live ember bed at least 3-4" (76 - 102mm) deep. This may take an hour or longer, particularly when the WinterWarm is vented to an exterior masonry chimney or when you are just starting a fire.

You'll soon find out that the WinterWarm is **HOT WHILE IN OPERATION! KEEP CHILDREN, CLOTHING, AND FURNITURE AWAY. CONTACT MAY CAUSE SKIN BURNS.**

**NOTE:** Some chimneys need to be "primed," or warmed up, before they will draw sufficiently to start a fire. To correct this situation, roll up a couple pieces of newspaper, place them on top of the kindling and toward the back of the stove, light them, and close the doors. This should heat the chimney enough to initiate a draft.

Once the draft is established, open the front door and light the rest of the fuel from the bottom. Do not light the main bed of fuel until the chimney begins drawing, and repeat the procedure as often as necessary if the initial attempt is unsuccessful.

4. Once a good ember bed of at least 3-4" (76 - 102mm) has formed, close the damper to activate the combustor. To ensure continued operation of the combustor, let the fire burn hot for an additional ten to fifteen minutes after the damper is closed.
5. Close the primary air control to a medium-low setting, or about 1/3 the distance from right to left in its travel range as described on Page 4. The fire volume will diminish immediately, but the WinterWarm will continue to heat up. Maintain control of the fire using the primary air control, and remember: reduce the setting for less heat, increase the setting for more heat. Refer back to the air control settings chart on Page 4 for recommended settings at different burn rates.

**DO NOT OVERFIRE THIS HEATER.** Overfiring may cause a house fire, or can result in permanent damage to the stove and to the catalytic combustor. If an exterior part of the WinterWarm glows, you are overfiring.

### Reloading and Reviving a Wood Fire

Open the stove damper, set the air control on "High," and wait at least fifteen seconds for the draft to increase. Open the door slowly.

Check the ash level, and empty the ash pan if necessary. Replace the pan.

Add the fuel, smaller pieces first. If it is necessary to use wood smaller than the 24" (610mm) optimum size, be sure to fill the firebox as completely as possible by loading the wood pieces alternately on the left and right. Split wood will fill the firebox more completely and reduce the frequency of reloading.

If you have an ember bed of at least 3 - 4" (76 - 102mm), leave the damper open and the thermostat set on "high" for 10-15 minutes, then close the damper. If the ember bed is less than 3 - 4" (76 - 102mm), you may have to let it burn longer.

Finally, adjust the air control and fan speed for your desired heat level.

**NOTE:** If the charcoal bed is relatively thick and your fuel is well-seasoned, it is possible to add fresh fuel (smaller pieces first), close the door and damper, and reset the air control within five minutes.

### Special Tactics for Cold-Climate Heating

The WinterWarm is capable of producing up to 50,000 Btu's/hour and heating an area of up to 1,500 ft.<sup>2</sup> (140 m<sup>2</sup>) However, many factors affect heating performance and can influence the extent to which the WinterWarm can heat a given area.

A well-insulated home, located in a moderate climate and with the WinterWarm Fireplace Insert or Fireplace System located centrally in an open floor plan, will be easier to heat than a drafty home in the far north in which a WinterWarm is installed on an exterior wall at the end of a long house.

In Fireplace Insert installations, over-sized chimneys can produce less effective results than those that are properly sized, and interior chimneys usually perform better than those located outside the house.

Different results may be experienced even in the same installation if you switch from burning good, dry wood to wood that is partially rotted or inadequately seasoned.

To compensate for these factors in cold climates, it may be necessary to operate the WinterWarm for longer periods of time than described above before closing the damper, or to leave the air control set to a higher level more of the time.

### Open-Fire Viewing with the Screen Cassette

The cassette screen that was included with your WinterWarm is interchangeable with the glass cassette, enabling you to convert from closed-door wood burning to protected open-fire viewing. Always leave the damper open when operating the WinterWarm with the screen in the open-fire mode.

To change cassettes, use this procedure:

Let the WinterWarm cool completely

- Open the door
- Loosen the two short retainer clips, one at each top corner of the cassette frame, and turn them to clear the frame.
- Tilt the top edge of the cassette away from the door frame.
- Carefully remove the cassette, being especially careful with the glass cassette. Store the unused cassette for future use.

- Examine the gasket that seals the cassette to the perimeter of the door frame. Contact your local dealer if you need a replacement gasket.
- Check the bottom channel of the door frame for debris, and clean if necessary.
- Insert the new cassette, bottom edge first, then the top edge.

**IMPORTANT:** The glass used in your WinterWarm is coated with a special material on one side that reflects heat back into the fire chamber. Before replacing a glass cassette that has been removed, examine the metal frame. One side has smooth, mitered corner joints; the other side has rough weld marks.

To install the glass correctly, the smooth mitered corners must be facing the gasket and the rough weld marks must be positioned toward the fire chamber.

- Replace the two retainer clips, applying just enough pressure to secure the cassette evenly against the gasket.

### Remove and Store Ash Safely

Check the ash pan before reloading the stove, and empty if necessary using the following procedure:

- Open the damper
- Open the load door (Fig. 7)
- Pull open the ash chamber door with the hooked end of the fall-away handle.
- If the ash level is nearing the top, place the removable cover over the pan and make sure it is completely engaged. Ash may contain hot coals and must be treated with extreme care.
- Take the pan outdoors and empty the ash into your ash container.

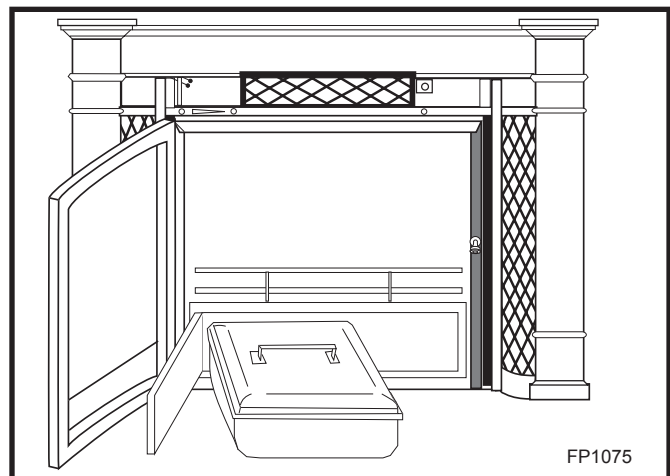


Fig. 7 Carefully remove ash pan.



- Before replacing the ash pan, clear away any ash that has spilled over the sides and back of the pan.
- Replace the ash pan and close the ash door and front door.

Empty the ash pan regularly, typically every one to three days. The frequency will vary depending on how you operate your WinterWarm: You burn more wood at higher heat output settings, and ash will accumulate faster.

Ash should be removed frequently and placed outdoors in a metal container with a tight-fitting lid. The closed container of ash should be placed on a noncombustible floor or on the ground, well away from all combustible materials, pending final disposal. If the ash is disposed of by burial in soil or otherwise locally dispersed, it should be retained in the closed container until all cinders have thoroughly cooled. -Wood ash may be used as a garden fertilizer.

**CAUTION:** Never use your household or shop vacuum cleaner to remove ash from the fireplace; always remove and dispose of the ash properly.

## Section II Maintenance

### Keep your WinterWarm Looking New and Working Its Best

#### Care of the Cast Iron Surface

An occasional dusting with a dry rag will keep the painted cast iron of your WinterWarm looking new.

If the paint needs retouching, first allow the surface to cool completely. Wire-brush areas needing to be painted. Touch-up with high temperature stove paint available from your local dealer. Apply the paint sparingly. Two light coats are better than one heavy one.

#### Care of the Porcelain Enamel Surface

Use a soft brush as necessary. Do not use water or other liquids on your WinterWarm. Fingerprints usually can be buffed off porcelain enamel with a dry, soft cloth. If marks remain, allow the WinterWarm to cool completely, then buff with a slightly damp, soft cloth. Dry completely before starting a fire to avoid streaking.

Never use abrasives or harsh chemical cleaners on the porcelain enamel finish. The enamel may scratch and expose the cast iron, which can then stain or rust. If you must remove spills or stains from porcelain surfaces, make sure that the fire is out and that the WinterWarm has cooled completely before cleaning. Use a kitchen appliance cleaner and polish especially formulated for enamel surfaces. Apply the cleaner sparingly with a soft cloth, and buff away all traces.

#### Cleaning the Glass

The WinterWarm glass system requires a minimum amount of cleaning. Most carbon deposits that accumulate will burn off during hot fires.

Ash residue that accumulates on the glass should be removed periodically to prevent etching. To clean the glass, follow this procedure:

- Be sure the glass is completely cool.
- Cleaning with water will work in most cases. Use a glass cleaner especially made for this purpose only if deposits are especially heavy. (If heavy deposits are a frequent occurrence, however, evaluate your operating techniques.)
- Rinse the glass thoroughly.
- Dry the glass completely.

**NOTE:** The WinterWarm glass is coated with a special material on one side that helps reflect heat back into the fire chamber. Do not attempt to remove this coating.

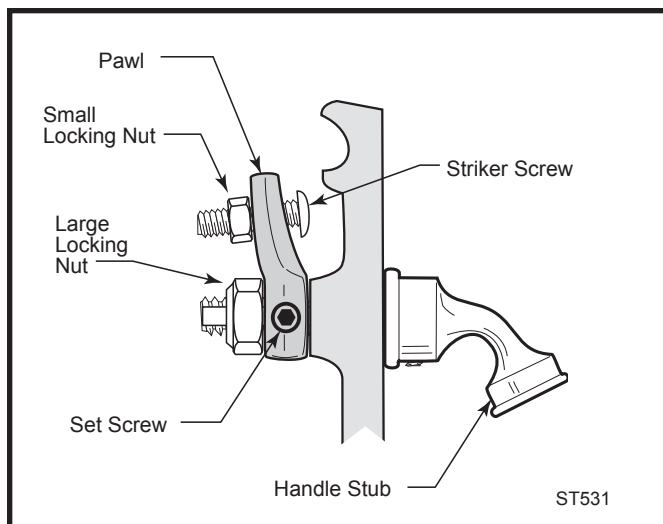
## Adjust the Door Latch Periodically

The front door of the WinterWarm should close securely to prevent accidental opening and should close tightly to prevent air from leaking into the fire chamber. The door handle will be positioned vertically when the door is closed.

Over a period of time, the gasket around the door will compress and the latch may need adjustment. To adjust the handle, follow this procedure (Fig. 8):

1. Loosen the small lock nut with a wrench.
2. Extend the striker screw one turn by turning it with an Allen wrench.
3. Re-tighten the lock nut, while at the same time holding the striker screw with the Allen wrench to prevent its turning.

Test the door seal. Close the door on a dollar bill and attempt to pull it free. If the bill is freed with little resistance, the gasket isn't snug enough at that spot. Contin-



**Fig. 8** An adjustable latch lets you restore a tight seal to the WinterWarm's door.

ue to make small adjustments until the setting is right.

If additional adjusting of the latch does not enable the door to seal sufficiently in one area, try "adjusting" the gasket in that area. Pack more cement or a smaller diameter gasket into the channel beneath the gasket so the main gasket is raised and makes contact with the door frame. This procedure should solve the problem. If it doesn't, replace the gasket following the directions below.

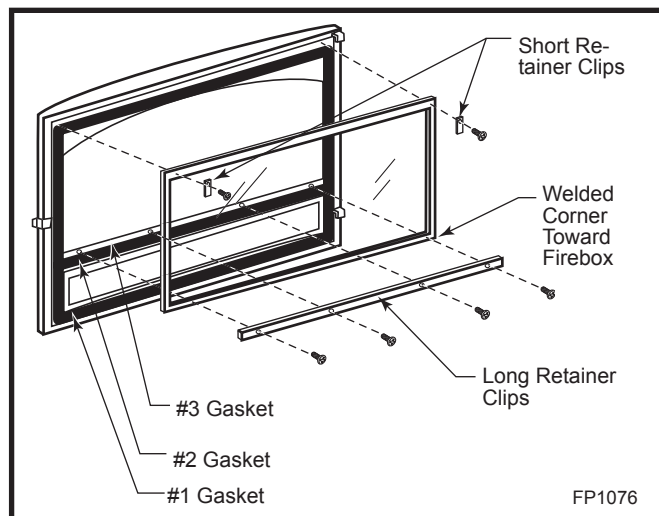
## How to Replace Gaskets

Your WinterWarm uses rope-type fiberglass gaskets to make a tight seal between some parts. With use, particularly on those parts that move, gaskets can become brittle and compressed and can begin to lose their effectiveness. These will need periodic replacement.

All of the gaskets used are made of fiberglass. The three sizes of replaceable gasket are listed below, along with their application.

### Replaceable WinterWarm Fiberglass Gaskets

<u>Gasket Size...</u>	<u>...And The Parts It Seals</u>
1/2"	The door to the front (#1)
1/2"	The door to the front edge of the grate (#2)
3/16"	The cassette glass seal to the door (#3)
3/8"	The damper to the upper fireback (#4)



**Fig. 9** Front door components allow replacement of the glass, gaskets or both.

Should you need to change a replaceable gasket, wait until the fire is out and the stove has cooled. Be sure to follow the standard safety procedure for working with dusty materials: Wear safety goggles and a dust mask. The procedure for replacing gaskets is the same, regardless of the gasket location. Four easily-accomplished steps are involved:

1. Remove the existing fiberglass gasket by grasping an end and pulling firmly.
2. Use a wire brush or the tip of a screwdriver to clean the channel of any remaining cement or bits of gasket.
3. Apply a thin bead of stove cement to the newly-cleaned groove.
4. Pack a new gasket into the groove. Wait until you have placed all but a couple inches from the end before you trim the end to an exact fit.

## Replacing the Door Gaskets

Remove the door by lifting it straight up off its hinge pins. Lay it face down on a padded surface.

Follow steps 1-4 as described above.

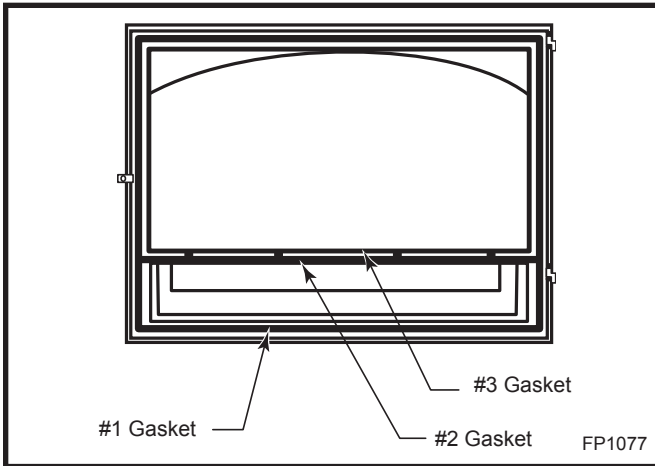


Fig. 10 Location of door gaskets.

## Replacing the Damper Gasket

Remove the front grate, bottom grate, ash pan, and ash pan frame.

Follow steps 1-4 as described above.

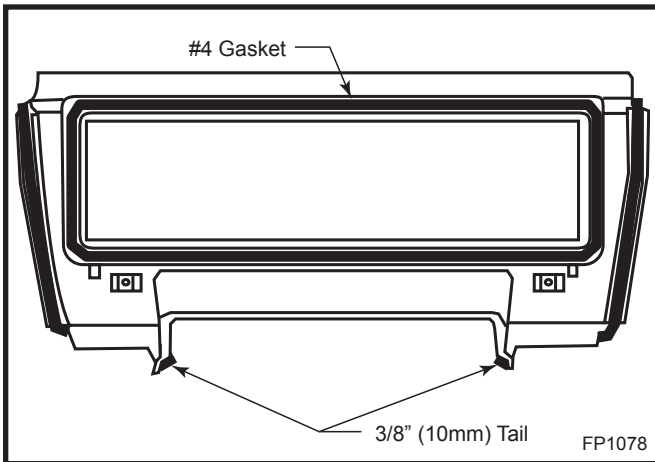


Fig. 11 Location of damper gaskets.

Other gaskets form seals between non-moving parts, but these are not subject to the same wear and deterioration as gaskets on moving parts. It is unlikely that you will ever need to replace these gaskets unless the involved parts are disassembled and then put back together. In any event, this is a job that should be done only by qualified service personnel.

## Permanent WinterWarm Gaskets

Gasket size...	...And The Parts It Seals
1/2"	The underside of the top plate to the top edge of the air manifold
5/16"	The flue collar to the top plate
5/16"	The right end of the air manifold to the right side plate
5/16"	The left end of the firechamber to the left end of the air manifold
5/16"	The bottom edge of the lower fireback to the bottom plate
5/16" and 3/8"	The ends of the upper fireback to the lower fireback and to the ribs of the right and left side plates

## Replace Damaged Door Glass Immediately

Do not operate the WinterWarm with a damaged glass (or screen) cassette. Use the following procedure for cassette replacement.

**NOTE:** Replace glass only with CFM Corporation high temperature ceramic glass, available from your Vermont Castings' Authorized Dealer.

- Open the door and loosen the two retaining clips, one at each upper corner, which hold the cassette to the door frame. Swing the clips out of the way. Tilt the cassette away from the door frame and lift up. Use caution when handling a cassette that contains broken glass.

- Examine the gasket that seals the cassette to the door frame. Replace if necessary with gasket obtained from your local Vermont Castings' Authorized Dealer. See the directions for gasket replacement on page 9.

- Check the channel at the bottom of the door frame, and clear away debris if necessary.

**IMPORTANT:** The glass used in your WinterWarm is coated with a special material on one side that reflects heat back into the fire chamber. Before replacing a glass cassette that has been removed, examine the metal frame. One side has smooth, mitered corner joints; the other side has rough weld marks.

To install the glass correctly, the smooth mitered corners must be facing the gasket and the rough weld marks must be positioned toward the fire chamber.

- Secure the clips, being careful not to over-tighten. Be sure the cassette is firmly seated against the gasket. Close the door gently to confirm that the clips have been properly positioned. It is possible for the glass to be damaged if the clips have been installed incorrectly and the door is closed with force.

## Adjust the Damper as Needed

Examine your WinterWarm's damper after the first 50 hours of use and adjust it if necessary. Thereafter, check the damper at least once a year and adjust as needed.

Both fine and coarse adjustments to the damper are possible. Begin with the fine adjustment, which modifies the pressure on the damper plate directly; it will take care of most sealing problems. Proceed to the coarse adjustment, which adjusts the pressure at the damper latch, only if you cannot achieve a satisfactory seal with the fine adjustment.

To inspect how well the damper seals, first make sure that the fire is out and that the WinterWarm is cool. Open the front door, and close and lock the damper. Visually inspect the seal between the damper plate and the damper frame; there should be no gaps. Now, push gently on the damper — there should be some give, but no rattle. If there is a gap in the seal or a rattle, adjust the damper.

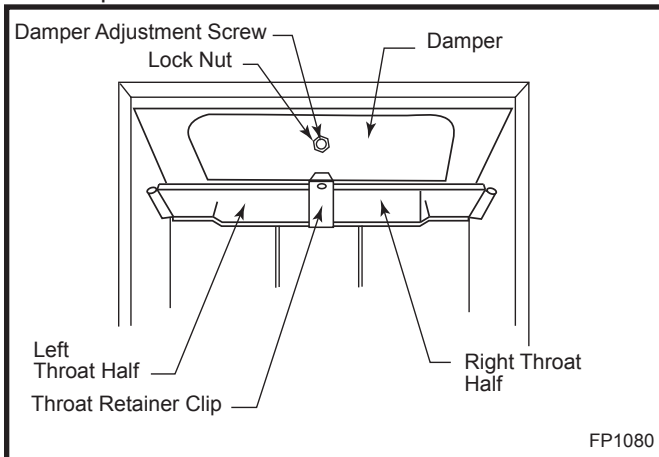


Fig. 12 A view of the damper as seen through the front door.

### Try the Fine Adjustment First

1. Open the door.
2. Close and lock the damper.
3. Locate the damper adjustment set-screw in the center of the damper plate, and loosen its lock nut.
4. Turn the set-screw 1/4 to 1/2 turn clockwise.
5. Check the damper seal for gap or rattle.
6. When the set screw position provides a good seal, tighten the lock nut. Be careful not to overtighten the set screw.

### Use the Coarse Adjustment Only If Necessary

Follow Steps 1-3 of the fine adjustment procedure, then;

1. Turn the set screw counter-clockwise several full turns.
2. Lift off the mantel piece to expose the damper latch.

3. With the damper open, loosen the latch retaining screw.
4. Move the latch approximately 1/8" (3mm) to the right, and retighten the retaining screw.
5. Close and lock the damper, and check for gap and rattle. Adjust the set screw as described under "Fine Adjustment."

Repeat the coarse adjustment if necessary.

For further assistance, contact your Vermont Castings' Dealer.

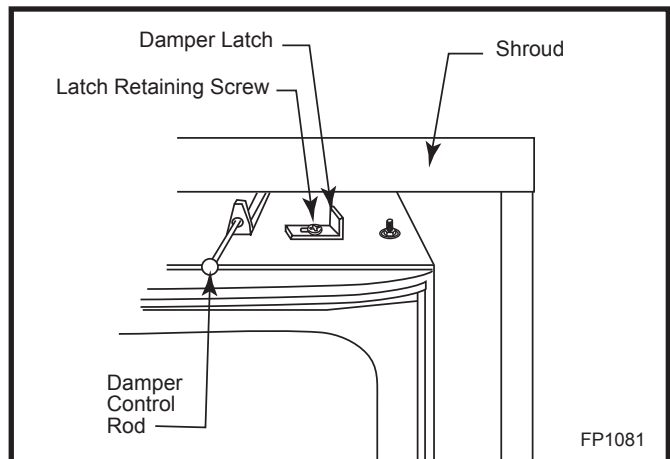


Fig. 13 With the mantel removed, the damper latch is exposed for adjustment.

## Care of the Catalytic Combustor

This wood heater contains a catalytic combustor, which needs regular inspection and periodic replacement for proper operation. It is against the law in the United States to operate this wood heater in a manner inconsistent with operating instructions in this manual, or if the catalytic element is deactivated or removed.

Under normal operating conditions, the catalytic combustor should remain active for two to six years (depending on the amount of wood burned). However, it is important to monitor the combustor periodically to ensure that it is functioning properly, as well as to determine when it needs to be replaced. A non-functioning combustor will result in a loss of heating efficiency, and an increase in creosote and emissions.

The combustor should be visually inspected "in place" for fly ash accumulation and physical damage three times per year. Actual removal of the combustor is not recommended unless a more detailed inspection is warranted because of diminished performance as outlined below.

The refractory package that houses the catalytic combustor should be inspected annually for a build-up of fly ash and cleaned if necessary. This may be done during examination of the catalytic combustor.

The catalytic combustion system includes an air supply for secondary combustion. The probe which controls the supply should also be inspected annually.

## When to Suspect a Combustor Problem

The best way to evaluate the performance of your WinterWarm's combustor is to observe the amount of smoke leaving the chimney — both when the combustor has achieved “light-off” and when it has not. Follow this simple two-step procedure:

- With a fire going and the combustor properly activated with the damper closed to route smoke through it as described in the Operation Section, go outside and observe the smoke leaving the chimney.
- Then, open the stove damper and once again observe the smoke leaving the chimney.

Significantly more smoke should be observed after the second step when the stove damper is open and exhaust is not routed through the combustor. Be careful not to confuse smoke with steam from wet wood.

If this test indicates a problem, consider other possible factors as well, such as the time of year or a change in the quality of your fuel. In spring and fall, draft is weaker than it is in colder winter weather, and fires can burn sluggishly. Small, hot fires are a good solution under these conditions.

Burning “green” (insufficiently seasoned) wood will result in poorer performance than when burning properly seasoned fuel. You may have to run your stove hotter (more air) to achieve good performance if you are burning green or wet wood.

Also, consider any changes in your operating routine as well.

Once you have ruled out any other possible causes for a decline in performance, you may proceed with an inspection of the combustor.

## Inspection and Removal of the Combustor

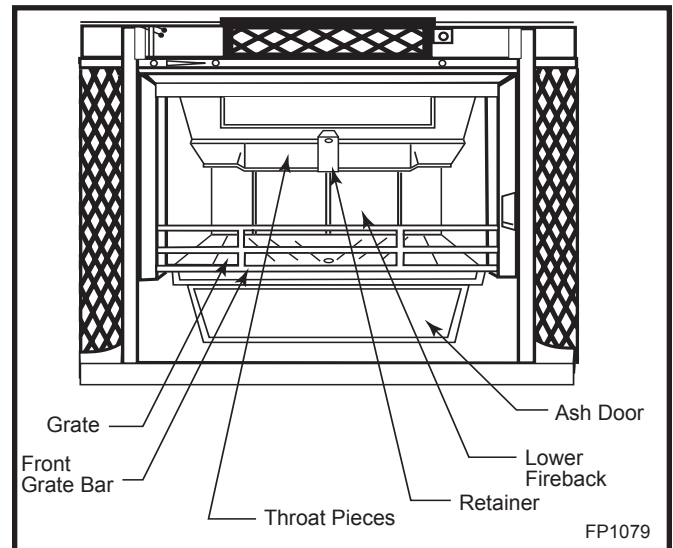
Before you begin, observe the basic safety precautions for working with dusty materials: always wear safety glasses, a recommended dust mask, and gloves. To expose the combustor, first remove the throat pieces by tapping upward at the far left and right corners with a soft-faced hammer. Leave the bolt in the retainer loose, and leave the retainer in place.

Examine the top surface of the catalytic element, which will be visible. A small mirror and flashlight may provide a better view. Unless the element shows a heavy fly ash accumulation or major damage, do not remove it.

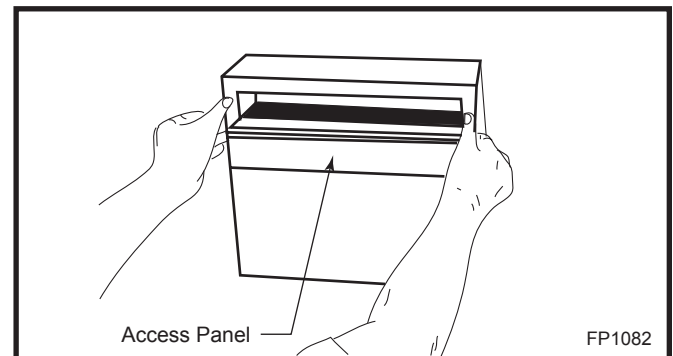
If combustor removal is necessary for cleaning or closer inspection, follow these steps (Fig. 14):

1. Remove the front grate bar.
2. Remove the grate.
3. Remove the throat pieces as described above

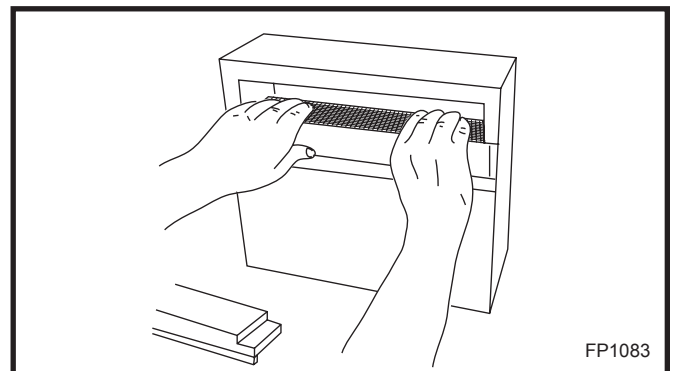
4. Tip the lower fireback forward, and remove it by lifting it up and toward you.
5. Carefully remove the access panel. (Fig. 15) It is extremely delicate and should be handled as little as possible.
6. Slide the catalytic element out. (Fig. 16) Handle it carefully, as the element is fragile.



**Fig. 14** To reach the catalytic combustor, remove front grate bar, grate, throat pieces and lower fireback.



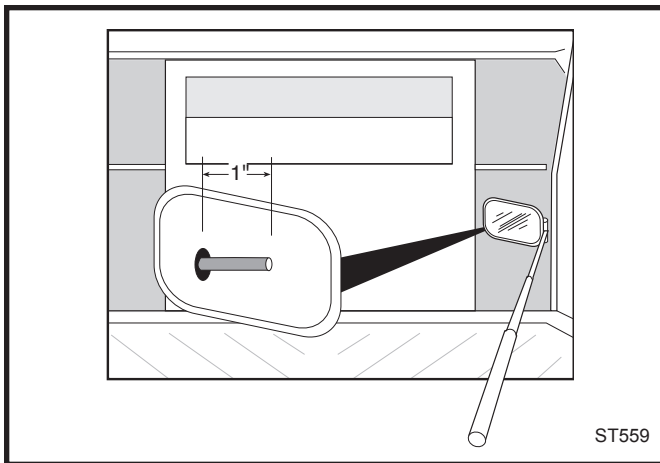
**Fig. 15** Remove the access panel.



**Fig. 16** Removing the catalytic element.



- Check the combustor and the bottom of the refractory chamber for a build-up of fly ash, and remove any ash by taking the combustor outside and gently blowing air through the element. Do not brush the surface, as this could damage the element. Carefully vacuum ash from the refractory chamber.
- Refer to the “Catalytic Combustor Appendix” on Page 37 for information on what kinds of damage or deterioration to look for. Although small hairline cracks will not affect performance, the combustor should be essentially intact. If the combustor is broken in pieces or has sections missing, it should be replaced. Call your local Vermont Castings’ dealer for a replacement combustor, item #30001152. Consult the warranty section at the back of this manual for further information on catalytic combustor replacement.
- While the catalytic element is removed, check the condition of the secondary air probe. Use an inspection mirror to locate the probe within the combustion chamber. (Fig. 17) The probe should extend 1 to 1½” (25 - 38mm) into the chamber and show no signs of deterioration, (warping, short length). Refer to the next illustration. A damaged secondary air probe could affect catalytic performance. If the probe needs to be replaced, call your local dealer.



**Fig. 17** Use an inspection mirror to check the secondary probe.

If the combustor is in good condition and clean, re-install it following this procedure:

1. Slide the element carefully back into the refractory chamber, seating it securely. The element must be fully to the rear of the support slot.
2. Install the access panel, making sure that it is flush with the outer surface of the main refractory package.
3. Check the slot in the rear bottom plate for debris, and clean if necessary.
4. Reinstall the lower fireback by inserting the base of the fireback in the slot. Tip the fireback up into place.
5. Reinstall the throat pieces, center edges first, then outer edges. Tap the throat pieces downward firmly to seat the lower fireback.
6. Replace the grate.
7. Replace the front grate bar. With the horizontal bars pointing down and away from you, angle the bar inside the firebox to seat the right end. Then, bring the left end forward and lower it into position.

### Watch for Better Results

Finish up by cleaning the chimney and chimney connector. Then, use your WinterWarm in a typical manner for two weeks and observe its performance, taking particular note of the smoke observation test described on Page 11.

If a problem persists, contact your local dealer for further advice about your particular situation.

### The Chimney System

#### A Clean Chimney System is Safer and Works Better

Although the catalytic combustion system in your WinterWarm can reduce creosote formation dramatically, it is not a substitute for regular inspection and cleaning of the chimney and chimney connector.

#### Learn to Recognize — and Avoid — Creosote

Your WinterWarm has been designed to reduce creosote build-up significantly. However, regular chimney inspection and maintenance must still be performed. For safety, good stove performance, and to protect your chimney and chimney connector, inspect your chimney and chimney connector on a regular schedule. Clean the system if necessary. Failure to keep the chimney and connector system clean can result in a serious chimney fire.

When wood is burned slowly, it produces tar, organic vapors and moisture which combine to form creosote. The creosote vapors condense in the relatively cool chimney flue of a slow-burning fire. As a result, creosote residue accumulates on the flue lining. When ignited, this creosote makes an extremely hot fire within the flue system that can damage the chimney and overheat adjacent combustible material. If a significant layer of creosote has accumulated — 1/8” (3mm) or more — it should be removed to reduce the risk of a chimney fire.

If you do experience a chimney fire, act promptly to:

- Close the damper and thermostat lever.
- Get everyone out of the house.
- Call the Fire Department.

You should inspect the system every two weeks during the heating season as part of a regular maintenance schedule. To inspect the chimney, let the WinterWarm cool completely. Then, using a strong light, sight up through the flue collar into the chimney flue. If it is not possible to inspect the flue system in this fashion, the firechamber must be removed to provide better viewing access.

If it is necessary to remove the firechamber to inspect or clean the chimney, this is how to do it:

- Let the WinterWarm cool.
- Disconnect the fan power cord.
- Remove the load door, grate bar, grate and ash door.
- Retract all four levelling screws until they bear no weight.
- If you installed the CFM Corporation Flex Connector System, bend the four retaining tabs on the Starter Piece until they are straight. Push the Starter Piece upward until it is clear of the shroud.
- Slide the firechamber forward until you have access to the fireplace opening.
- Remove any sealing plates and the chimney connector from the fireplace damper frame area.

You can now inspect the smoke shelf area and the chimney. Before replacing the WinterWarm, this area should be inspected for signs of deterioration and cleaned thoroughly with a chimney brush.

Clean the chimney using a specially designed brush the same size and shape as the flue liner. Flexible fiberglass rods are used to run the brush up and down the liner, causing any deposits to fall to the bottom of the chimney where they can be removed through the clean-out door.

The chimney connector should be cleaned by disconnecting the sections, taking them outside, and removing any deposits with a stiff wire brush. Reinstall the connector sections after cleaning, being sure to secure the individual sections with sheet metal screws.

If you can't do the chimney inspection yourself, contact your local Vermont Castings' Authorized Dealer, or engage a professional chimney sweep to perform the inspection and cleaning of the chimney.

If you are the owner of a WinterWarm Fireplace System, the prefabricated chimney used with your fireplace should be cleaned from above using an 8" round brush and the appropriate number of extension rods for complete access.

The chimney cap first must be removed following the procedure recommended by the manufacturer. After thoroughly cleaning the chimney, reinstall the chimney cap according to the manufacturer's directions.

## WinterWarm Maintenance Schedule

### Fireplace:

#### Daily:

- Ash should be removed before the level reaches the top of the pan. Check each time you re-load, or at least once a day.
- Keep the area around the fireplace clear of any combustible material.

#### Yearly Spring Cleaning:

- Remove ash from the fire box and replace with a moisture-absorbing material (such as Kitty Litter) to keep the interior of the fireplace dry.
- Touch up painted surfaces with black paint.

### Flex Connector:

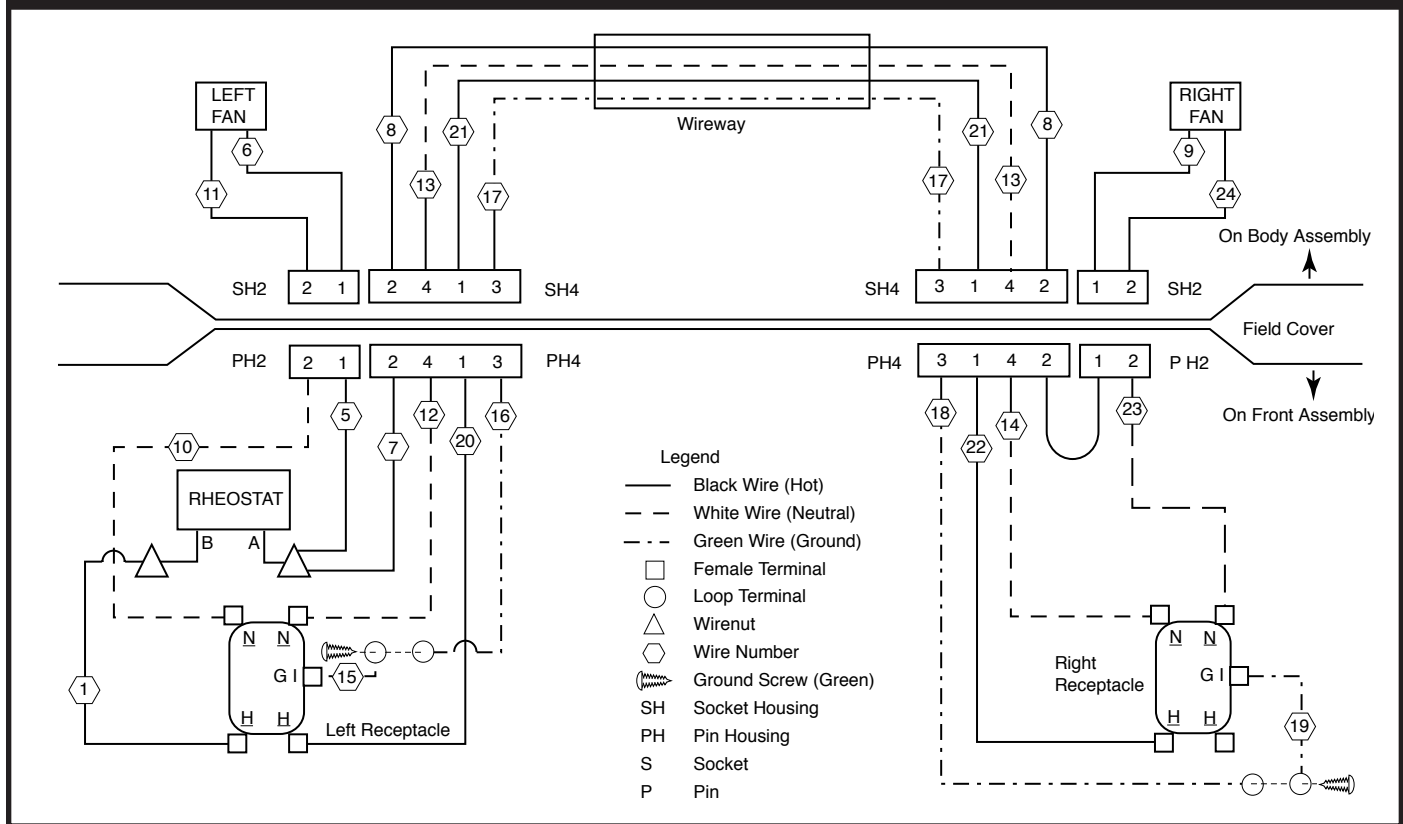
#### Two Weeks:

- Inspect the chimney and flex connector. Clean the system if necessary.

#### YEARLY SPRING CLEANING:

- Disassemble the flex connector and take it outdoors for inspection and cleaning. Replace weak sections of connector.
- Inspect the chimney for signs of deterioration. Repairs to a masonry chimney should be made by a professional mason. Replace damaged sections of prefabricated chimney. Your local Vermont Castings' dealer or a chimney sweep can help determine when replacement is necessary.

### Large WinterWarm Wiring Diagram



## Section III: Preparing a Masonry Chimney

Installing the WinterWarm into a masonry fireplace is an effective way to add an efficient heater to your home.

### Requirements for the Existing Masonry Fireplace

The WinterWarm Fireplace Insert is listed only for installation within a properly built masonry or heat circulating, masonry-type fireplace that is constructed in accordance with the requirements of recognized building codes. A heat-circulating masonry-type fireplace must conform to building code standards for masonry fireplaces, and must consist of a factory-built metal firebox with air circulation pathways that are surrounded by masonry materials.

**NOTE: The WinterWarm is not listed for use in “zero-clearance” prefabricated fireplaces, except when used as part of the Vermont Castings’ WinterWarm Fireplace system, including the WinterWarm Fireplace Energy Cabinet, item #2110 (referred to on the WinterWarm safety label as Fireplace Cabinet Model 1283).**

The fireplace and chimney must be clean and structurally sound. Have it inspected by a qualified professional chimney sweep, a mason, or your Vermont Castings’ Authorized Dealer before the WinterWarm is installed. Any deterioration (cracks, loose mortar or loose bricks) must be repaired.

The fireplace should not be modified to install the WinterWarm without first checking with your local building inspector or fire marshal. Do not remove bricks or mortar that may jeopardize the compliance of the fireplace with local building codes.

### Requirements of your Existing Masonry Chimney

Your fireplace chimney must be well-constructed and must meet minimum code requirements. The chimney flue should have a code-approved liner made of masonry or pre-cast refractory tiles, straight or flexible stainless steel pipe, or a poured-in-place liner. An unlined chimney must be relined professionally. Chimney height should be no less than 15’ (4.6m) above the hearth and no more than 35’ (10.7m).

The chimney must have a nominal flue size of 8” x 8” (203 x 203mm) or larger, with a maximum size of 12” x 12” (305 x 305mm). Some chimneys originally designed for fireplace use may perform differently when used to vent an air-controlled appliance such as your WinterWarm. A chimney on an outside wall with a large

flue, for example, may not heat up enough to sustain an adequate draft. Such a flue can often be improved if it is relined to reduce its size and/or insulated to keep it warmer.

The chimney should extend at least 3’ (914mm) above the highest point where it passes through a roof, and at least 2’ (610mm) higher than any portion of a building within 10’ (3m). (Fig. 18)

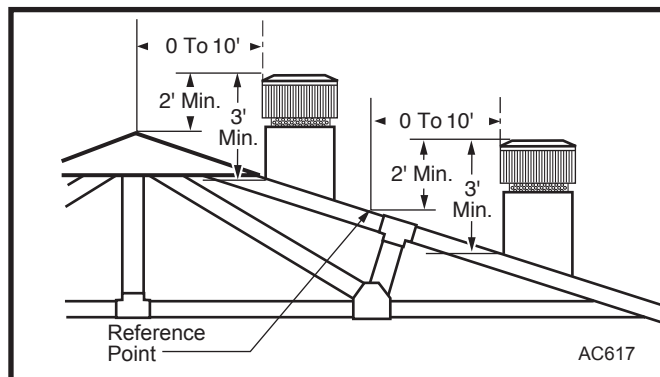


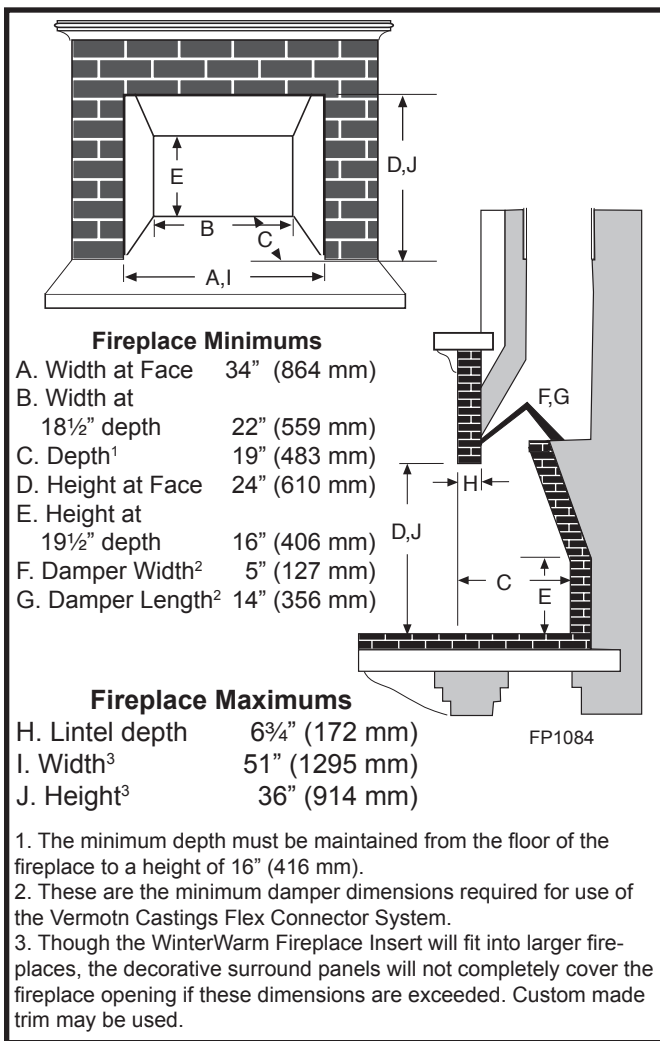
Fig. 18 The 2’3’10’ rule for chimneys.

Existing masonry fireplace chimneys, especially older ones, may have one or more openings used at an earlier time to connect stoves in different rooms to the fireplace chimney. These openings must be sealed with masonry to the thickness of the chimney wall. Unused openings sealed with pie plates or wallpaper are a hazard. In the event of a chimney fire, flames and smoke may be forced out of these unused openings.

**Do not connect your WinterWarm fireplace insert to a chimney flue serving another appliance.**

### Minimum Fireplace Dimensions

The WinterWarm Fireplace Insert will fit most masonry fireplaces. To confirm that it will fit yours, measure the lintel depth, plus the height, width, and depth of your fireplace and your hearth. Compare them to the measurements in the accompanying chart. If you choose to install a new hearth over an existing fireplace hearth, be sure to take its thickness into consideration when measuring both front and back height of the fireplace.



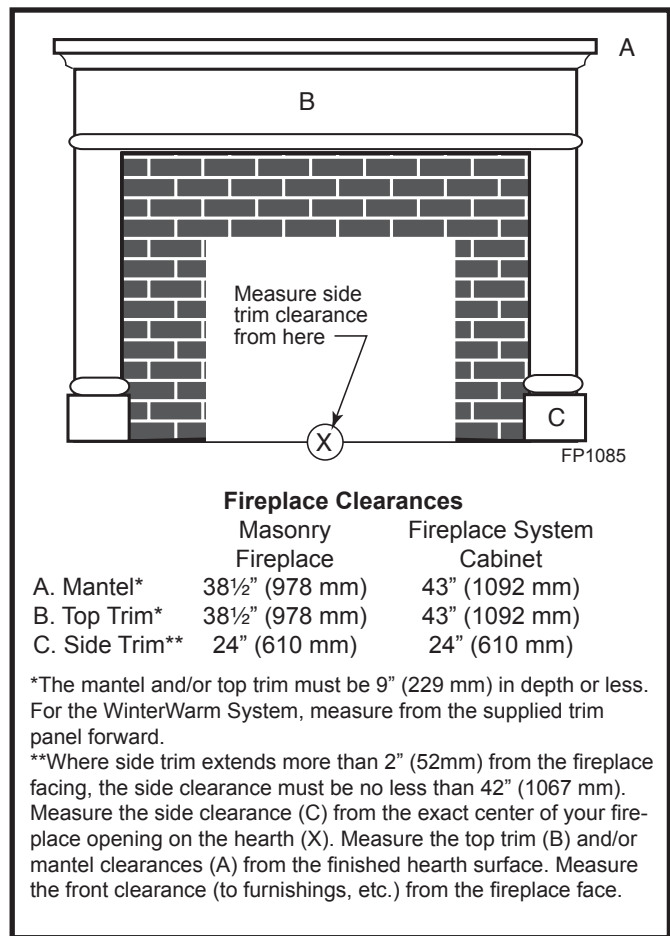
**Fig. 19** Use these measurements to confirm that the WinterWarm will fit into your masonry fireplace.

### Clearance Requirements

After confirming that your fireplace is the right size, check the clearances to combustibles. First mark with tape the exact center of your fireplace opening on the hearth. Measure the side clearance from this point. Measure the top trim and/or mantel clearances from the finished hearth surface. Measure the front clearance (to furnishings, etc.) from the fireplace face.

**NOTE:** The clearance between the WinterWarm Fireplace Insert and the mantel, top trim and side trim cannot be reduced by installing shields.

Another clearance requirement to consider is that for movable items such as tables, bookcases, rugs, furnishings, and your woodbox. All combustible materials of this type should be a minimum of 48" (1219 mm) from the front surface of the WinterWarm. Be sure that family members are aware of this requirement as well, so they too will keep objects a safe distance from the WinterWarm.



**Fig. 20** Observe these clearances to combustible trim.

### Hearth Requirements

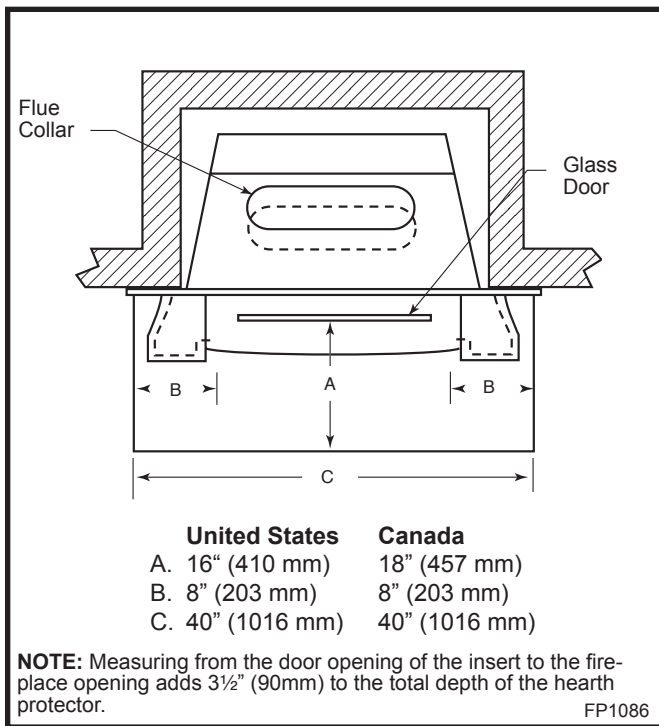
In some fireplaces, the hearth in front of the fireplace opening is brick, stone, slate, or some other non-combustible material that is in direct contact with concrete poured over earth. These are the only hearths that are considered noncombustible.

In other fireplaces, the brick or concrete hearth in front of the fireplace opening is supported by heavy wooden framing. Because neither brick nor concrete has good insulating properties, heat radiated by the fire will pass downward through the hearth to the wooden framing. Such hearths are considered combustible.

Unless the fireplace and hearth are constructed over a completely noncombustible surface (such as unpainted concrete over dirt), a floor protector must be used in WinterWarm Fireplace Insert installations in front of and to the sides of the door as protection against spilled coals and embers.

Floor protectors must extend at least 8" (203 mm) from the side of the door opening, making the protector 40" (1016 mm) wide. In addition, the floor protector must extend from the front door opening a minimum of 16" (410 mm) in the United States and 18" (457 mm) in Canada.





**Fig. 21** Unless your fireplace and hearth are constructed over a dirt floor (or unpainted concrete over dirt), you must use a floor protector that satisfies the above requirements.

The approved construction of a floor protector calls for 24 gauge galvanized sheet metal covered with a listed floor protector material that is at least 7/16" (11 mm) thick (such as Wonderboard® or Durock®). The floor protector may be covered with a noncombustible decorative material if desired. (Fig. 21)

Custom-made floor protectors may be used if they offer the same protection as the approved floor protector described in the preceding paragraph, which in testing was found to have a standard K value of 0.84. Custom-built floor protectors must have a K value equal to, or less than, 0.84, meaning that heat will transfer at the same rate or more slowly than the tested standard.

To calculate the thickness required for an alternate material to result in a K value of 0.84, first determine the alternate material's K factor. This information should be available from your local building supply yard. Then, calculate the following formula:

$$\frac{\text{(K factor of alternate material)}}{(0.84)} \times (7/16" [11mm]) = \text{(Required thickness of alternate material)}$$

Let's use brick as an example, since it is a commonly used hearth material. Its K factor is 5.0.

$$\frac{(5.0)}{(0.84)} \times (7/16" [11mm]) = 2.6" (65mm)$$

That is, when using brick for the hearth extension, the brick must be a minimum of 2.6" (65 mm) thick.

Once you know the K factor of a given material, you can use this same formula to calculate its required thickness for approved hearth protection.

**NOTE:** Any floor protector thicker than 9/16" (14mm) will require elevating the firechamber on a solid, approved floor protector to provide enough clearance for the door to open. This in turn will require a higher fireplace opening to permit installation of the fire chamber.

### The Chimney Connector

Connect your WinterWarm Fireplace Insert to the chimney flue with a "positive flue connection." Such a connection provides a direct passageway for smoke and exhaust gases leading from the flue collar of the WinterWarm to the first chimney lining tile. Positive flue connections are required in many areas before an installation can be approved.

The chimney connector itself should have a minimum cross-sectional area of 50 square inches (320 square centimeters), equivalent to an 8" (203 mm) diameter opening, and must be 24 gauge or heavier.

### Sealing Requirements

It is important to seal off the flue completely from the room air for proper operation of your WinterWarm. There are three ways to accomplish this:

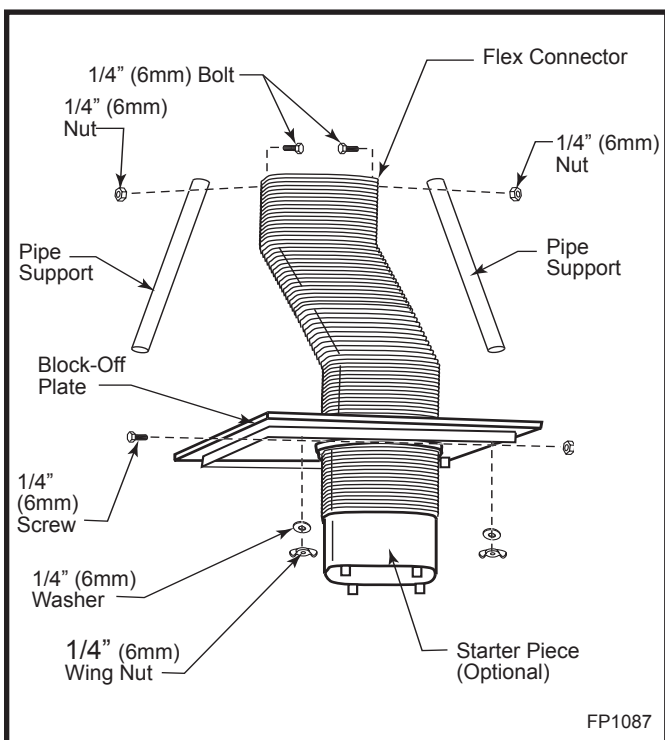
1. Install a CFM Corporation Flex Connector system;
2. Install a customized seal at the damper level;
3. Have your chimney professionally re-lined and connect the liner directly to the WinterWarm.

Of these three choices, the Flex Connector not only provides an effective seal but usually is the easiest to install.

### The Flex Connector System

The Flex Connector bends the chimney connector through angled smoke chambers and narrow damper frames, and its Block-off plate makes a tight seal at the damper frame. (Fig. 22)

To determine the suitability of the Flex Connector for your fireplace, carefully examine the fireplace damper area. The damper opening must be unobstructed and must measure at least 5" x 14" (127 x 356 mm) to accommodate the Flex Connector and the Block-off Plates. An undersized opening, or an opening obstructed by heat exchanger tubes or damper components, may prevent the Flex Connector from extending up to the flue or may be possible only after special work has been done.



**Fig. 22** Components of the Flex Connector System.

Consult a Vermont Castings' Authorized Dealer for installation suggestions. It may be possible to enlarge the opening by removing or modifying the damper frame, but do this only if it won't weaken the fireplace. Check with your local building inspector to be sure modifications comply with local codes.

Although the Flex Connector is designed to be installed by any mechanically competent person, wide variations in fireplace and damper construction can complicate the installation. You may wish to have the job done by a professional installer. Complete detailed installation instructions are included with the Flex Connector components.

### A Custom Damper Seal

If the design of your fireplace damper prohibits the use of the CFM Corporation Sealing Package, an alternative is to fabricate a custom sealing plate at or below the fireplace damper frame. The plate can be fastened securely to the lintel (the structural piece spanning the fireplace opening) and to the surrounding masonry, or be securely fastened to the damper frame. A section of chimney connector, attached to the WinterWarm flue collar, must make a positive flue connection where required by code.

### A Relined Chimney

There are a number of fittings available from your Vermont Castings' Authorized Dealer that are designed to form the connection between your WinterWarm and an 8" (203mm) diameter chimney liner. Your dealer as well as your local chimney sweep can advise you on the types of lining systems currently available.

### Preliminary Steps for Installing the WinterWarm into a Masonry Fireplace

#### 1. Remove the Masonry Fireplace Damper

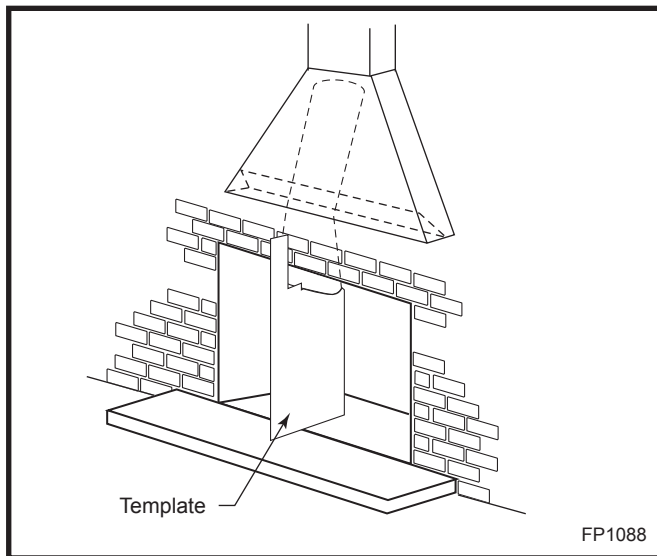
The existing damper plate within your fireplace must be removed or, if that is not possible, must be fastened securely in a fully-open position. Many dampers can be removed simply by removing a cotter pin and/or set screw.

#### 2. Install the Flex Connector

Following the installation instructions that are packed with the Flex Connector, unfold the template that came with the WinterWarm. (Fig. 23) Carefully glue the template onto a large piece of sturdy cardboard or plywood, making sure that the fold lines have been flattened. Cut along the edges of the template and use it to place the Flex Connector components correctly in your fireplace.

#### Custom Fabrication:

Be sure any chimney connector or adapter is properly installed and secured in place. There should be a slip joint near the WinterWarm so that the connection can be easily disengaged for removal and cleaning of the unit.



**Fig. 23** Using the template that came with the WinterWarm will help you position Flex Connector.

### 3. Reverse the Flue Collar (If Necessary)

The flue collar of the WinterWarm is reversible to allow for installation into fireplaces with different lintel depths and different damper orientations. It is shipped in the rear-most position (the deep lintel position), which accommodates lintel depths up to 6¾" (172 mm). The fore-most flue collar position will accommodate lintels as shallow as 4¾" (121 mm) in depth.

Taking into account the location of the damper frame, choose the flue collar position that enables the chimney connector to be installed using the most gradual bend possible.

To reverse the flue collar, remove the flue collar insert panel located on top of the shroud by removing the sheetmetal screws around the panel's perimeter. Remove the two fasteners that attach the flue collar to the insert panel, then remove the panel. You then have access to the top plate and to the flue collar.

Remove the four fasteners that attach the flue collar to the top plate of the WinterWarm. Lift the flue collar away from the top plate. Position the flue collar in the desired orientation, and reinstall the four fasteners. Make sure the flue collar is seated firmly against the gasket material.

Replace the flue collar insert panel. Fasten the flue collar to the panel, and re-install the sheet metal screws around the panel's perimeter.

### 4. Install the Floor Protector

Make sure the floor protector satisfies the requirements discussed on Pages 17 and 18.

### 5. Assemble the Optional Surround Panel and Lean it against the Front of the Fireplace

If your installation will include the optional surround panels, assemble them according to the instructions packed with the panels. Lean the finished assembly against the chase front.

The CFM Specialist Home Products modular Surround Panels cover gaps up to 4½" (116 mm) using a single panel, and up to 9¼" (231 mm) using double panels. Surround Panel kit #3014 has outside measurements of 31¾" tall by 43⅞" wide (806mm tall x 1114 mm wide); by combining Kit #3014 with extension kit #3015, the resulting surround is 35⅞" tall by 51½" wide (903 mm tall by 1308 mm wide).

Custom-made surround panels may be made from any noncombustible material, with the following restrictions: The maximum suggested thickness of the surround material is determined by both flue collar position and lintel depth. For installations using the front flue collar position, the maximum suggested surround thickness is 4" (102 mm) minus the lintel depth. For example, a 3" (75 mm) lintel would result in a maximum surround thickness of 1" (25 mm).

There is no need to attach the surround panels to the insert or to the fireplace. The modular surrounds are sized to stand without additional support or attachment; they are simply trapped between the fireplace insert's cast-iron front, and the face of the fireplace.

For rear exit flue positions, the suggested position would allow a surround thickness of 3½" (88 mm).

With these preliminary steps completed, you can now proceed to install the WinterWarm firechamber and front. That information is located in Section V, "Completing the WinterWarm Installation," and begins on Page 29.

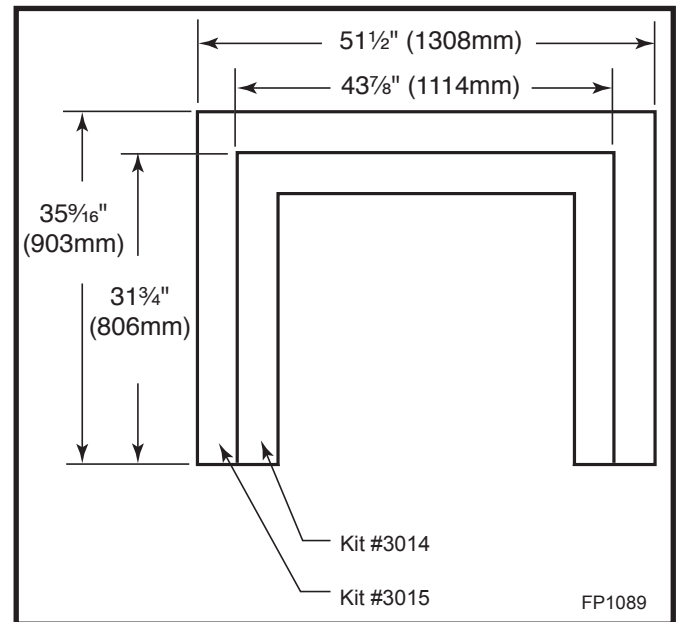


Fig. 24 CFM Corporation #3014 and #3015 Optional Surround Trim Kits.

## Section IV: Installing the Fireplace System Cabinet

The insulated metal cabinet included with the WinterWarm Fireplace System enables the WinterWarm Fireplace Insert to be installed in minimum-clearance situations and where no masonry fireplace or chimney exists, such as in new home construction or in renovation.

**Use only CFM Corporation WinterWarm firechamber Model #2100 in this fireplace cabinet. Do not use other products not specified for use with this fireplace. The two (2) vent ducts supplied with the energy cabinet must be installed as described in this manual. Never install the energy cabinet without installing the vent ducts.**

### Carefully Observe Local Building Codes

Meeting the requirements of your local building codes is an important part of planning your WinterWarm installation. Because the final approval for an installation is always granted by local officials, and because codes vary in different areas, involving your local officials in the planning stage can help facilitate the approval process. Review your plans with them before beginning the installation.

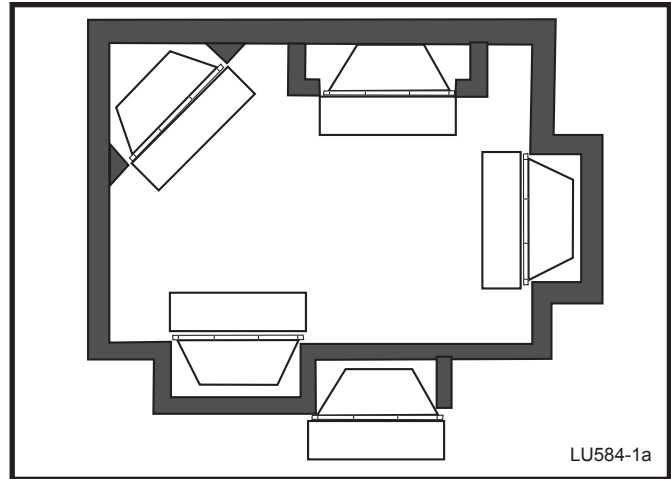
Ask your Vermont Castings' Authorized Dealer for help in providing the necessary information to local officials.

In the pages that follow you'll find information on planning, construction, and clearance for almost all installations. If you need further assistance, refer to the National Fire Protection Association ANSI/NFPA 211-1988 Standard for Chimneys, Fireplaces, Vents and Solid Fuel Burning Appliances, or, in Canada, CSA B365. Your local Vermont Castings' Authorized Dealer or your local building official may have a copy.

### Selecting a Location for Your Fireplace

Centrally located installations circulate the heat most effectively and take full advantage of the WinterWarm's powerful heating capability. (Fig. 25)

An interior chimney is preferred, as it stays warmer and provides a more reliable draft than a chimney on the outside of the building. Locating the chase on an exterior wall has the advantage of reducing the existing floor space required by the installation, however, and an exterior chimney can be enclosed in a chase built to resemble a traditional fireplace and insulated to keep it warmer.

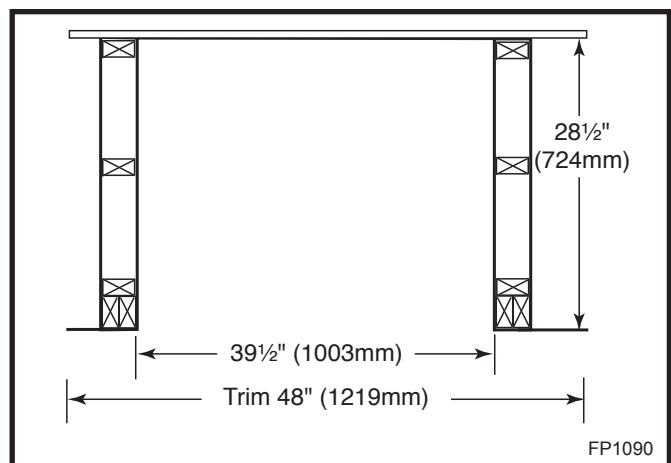


**Fig. 25** The WinterWarm Fireplace System offers a variety of siting options.

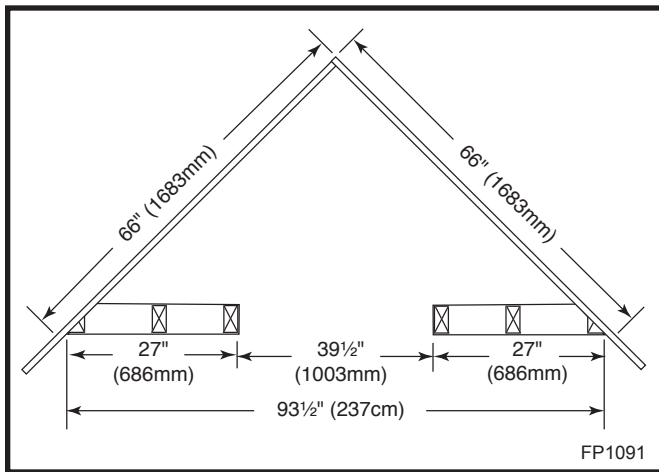
### Structural Considerations of the Installation

#### Chase Dimensions

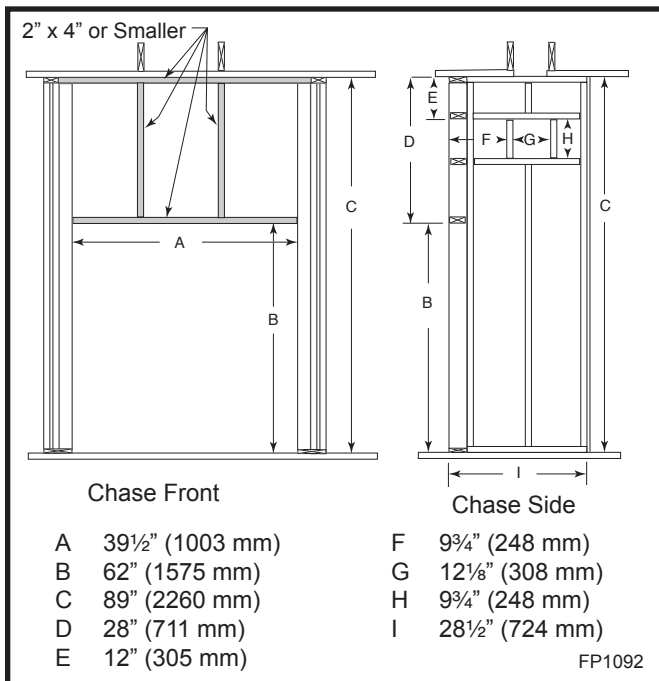
The WinterWarm Fireplace System installs in an opening just 28½" (724 mm) deep, 39½" (1003 mm) wide, and as little as 89" (226 cm) high. (Fig. 26) The enclosing chase will be wider by the thickness of studding and drywall, or other wall finish material. The basic trim package requires an overall enclosure width of at least 48" (1219 mm), plus the width of any edge molding to be applied. The chase must be at least 89" (226 cm) high.



**Fig. 26** Minimum dimensions for framing the WinterWarm Fireplace System when the chase is oriented perpendicular to wall.



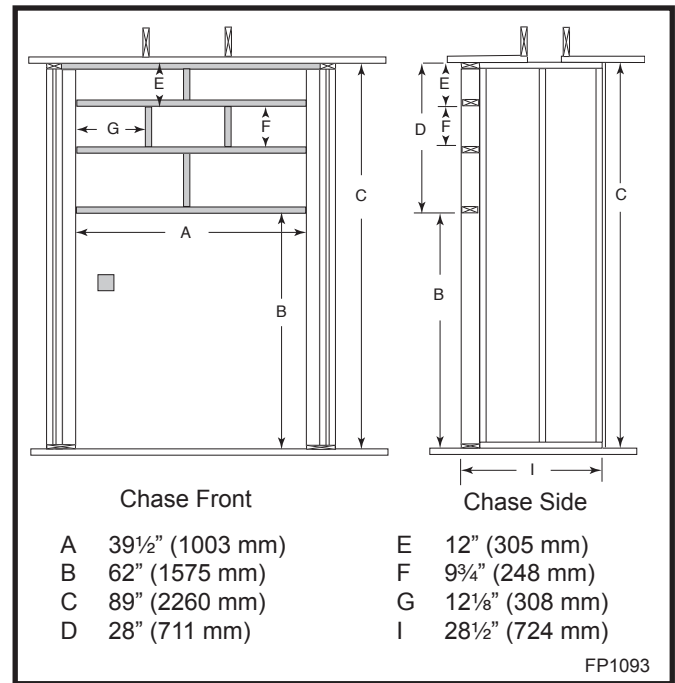
**Fig. 22** Minimum dimensions required for framing a corner installation of the chase.



**Fig. 28** Suggested dimensions and framing for side-venting the air ducts of the chase.

### Duct and Vent Placement

The WinterWarm offers great flexibility in positioning the hot air ducts. The ducts can vent through the side of the chase, through its front, or one each through both the side and the front. Either or both ducts also may be vented into a room behind, beside or above the room in which the WinterWarm is installed. **Both ducts must be installed in order to properly vent the hot air inside the energy cabinet. Failure to connect the vent ducts could result in overheating of the cabinet and surrounding construction. The ducts must be installed at least 12" (305 mm) from the ceiling and no lower than the cabinet top.**



**Fig. 29** Suggested framing and dimensions for venting the air ducts through the chase front.

Figures 28 and 29 show construction dimensions for some of the common duct placements.

### Chimney Requirements

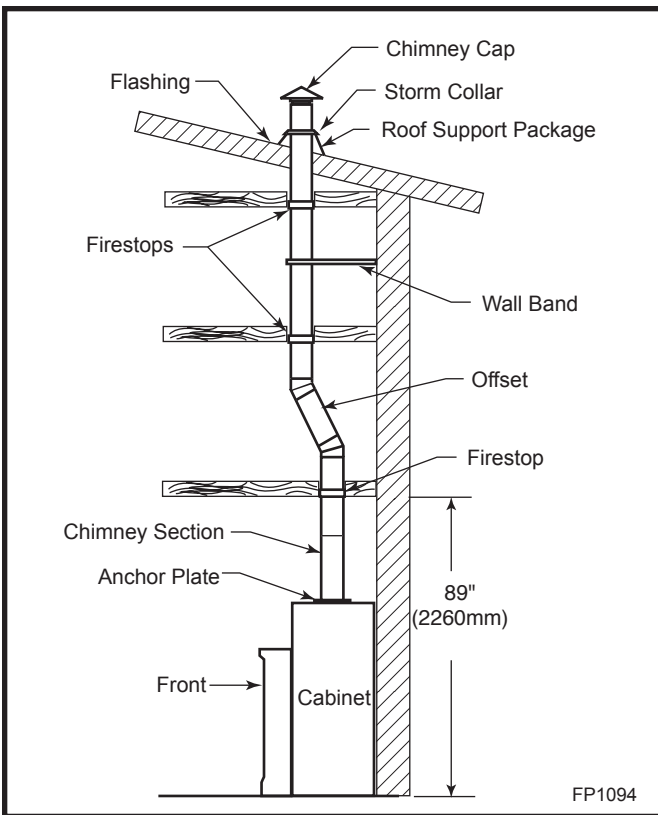
For proper draft and best performance, the chimney should extend at least 15' (4.6 m), and not more than 35' (10.6 m), above the hearth surface. If the chimney above the roof line is enclosed in a chase, the chimney must extend at least 3' (914 mm) above the top of the chase. The chimney must be supported either from the roof or from the floor joists above the WinterWarm. The cabinet is not intended to be the sole support of the chimney. Support systems are available from the chimney manufacturer.

An installation with a straight, vertical chimney will have the best draft and is the easiest to clean.

If structural components such as floor joists or roof rafters are obstacles to the chosen location, however, up to four 30° elbows may be connected directly to each other. Used in pairs, the elbows will return the chimney pipe to vertical after it has passed the obstacle. (In some instances floor joists can be cut and boxed in for reinforcement, but engineered roof trusses should never be cut.) The first offset must be at least 8' (2.5 m) above the hearth. Elbows may not be used within the chase.

The WinterWarm Fireplace System is listed for use in the United States with seven 8" (203 mm) diameter chimney systems that have been listed to High Temperature (H.T.) Chimney Standard UL-103-1985 (2100°F).





**Fig. 30** Typical chimney components used in the installation of a WinterWarm Fireplace System.

The listed chimneys and their manufacturers are:

American Metal Products	Ameri-Tec Model HS
Condensation Engineering Corp.	Model HS
GSW Building Product Co.	Model SC
Metal Fab, Inc.	Model TG
Security Chimneys Ltd.	Model ASHT
Selkirk Metalbestos	Model SSII
Simpson Dura-Vent	Model SDP

In the United States, do not use any other chimney system with the WinterWarm Fireplace System.

In Canada, the WinterWarm Fireplace System is listed for use with any 200 mm diameter prefabricated chimney tested and listed to the High Temperature (650°C) Chimney Standard, ULC S-629.

### Guidelines for an Outside Air Supply

Outside air may be introduced to the WinterWarm at either of two available ports: at the lower left corner of the back of the cabinet (as viewed from the front), or at the lower left corner of the left side panel.

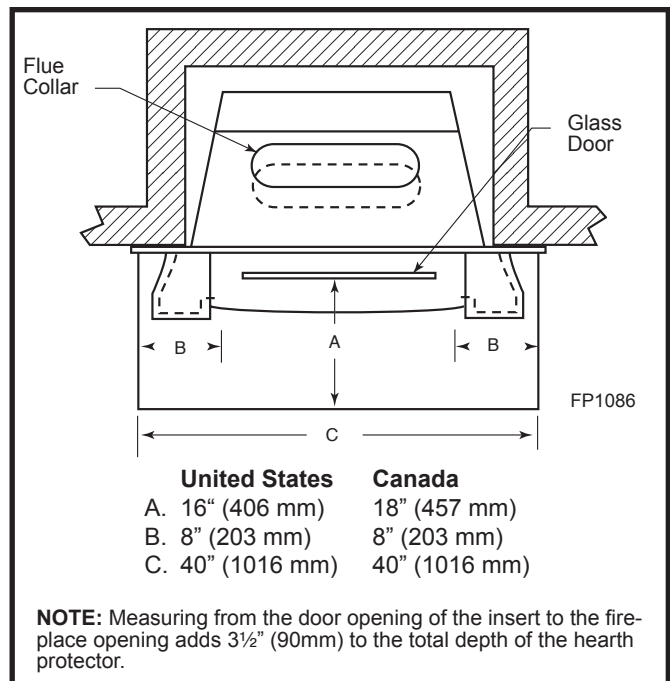
An outside air duct must be 3" (75 mm) in diameter, must be no longer than 20' (6 m), and must not have more than three elbows. No part of the outside air duct (including the outside air inlet) may be higher than the

cut-out panel on the WinterWarm shroud, and it should terminate at an outside air source. It may not terminate in a garage or basement, nor near another fuel-fed appliance. The air inlet must be covered by a wire mesh screen (not included) with openings not larger than 1/4" x 1/4" (6 x 6 mm) to prevent rodents from entering from the outside. The optional duct kit includes a valve to close off incoming air when the WinterWarm is not in use.

### Hearth Requirements

Unless the Fireplace System Cabinet will be installed on a completely noncombustible surface such as unpainted concrete over earth, a floor protector must be used in the installation for protection against radiated heat as well as protection against spilled coals and embers.

Floor protectors must extend at least 8" (203 mm) from the side of the door opening, making a total width of 40" (1016 mm). In addition, the floor protector must extend from the front door opening a minimum of 16" (410 mm) in the United States and 18" (460 mm) in Canada. (Fig. 31)



**Fig. 31** A floor protector must satisfy these requirements.

The approved construction of a floor protector calls for 24 gauge galvanized sheet metal covered with a listed floor protector material that is at least 7/16" (11 mm) thick (such as Wonderboard® or Durock®). The floor protector may be covered with a noncombustible decorative material if desired.

Custom-made floor protectors may be used if they offer the same protection as the approved floor protector described in the preceding paragraph, which in testing was found to have a standard K value of 0.84. Custom-built floor protectors must have a K value equal to, or less than, 0.84, meaning that heat will transfer at the same rate or more slowly than the tested standard.

To calculate the thickness required for an alternate material to result in a K value of 0.84, first determine the alternate material's K factor. This information should be available from your local building supply yard. Then, calculate the following formula:

$$\frac{\text{(K factor of alternate material)}}{\text{(K factor of Wonderboard)}} \times \text{(Thickness of Wonderboard required)} = \text{(Required thickness of alternate material)}$$

Let's use brick as an example, since it is a commonly used hearth material. Its K factor is 5.0.

$$\frac{(5.0)}{(0.84)} \times (7/16" [11 \text{ mm}]) = 2.6" (65 \text{ mm})$$

That is, when using brick for the hearth extension, the brick must be a minimum of 2.6" (65 mm) thick.

Once you know the K factor of a given material, you can use this same formula to calculate its required thickness for approved hearth protection.

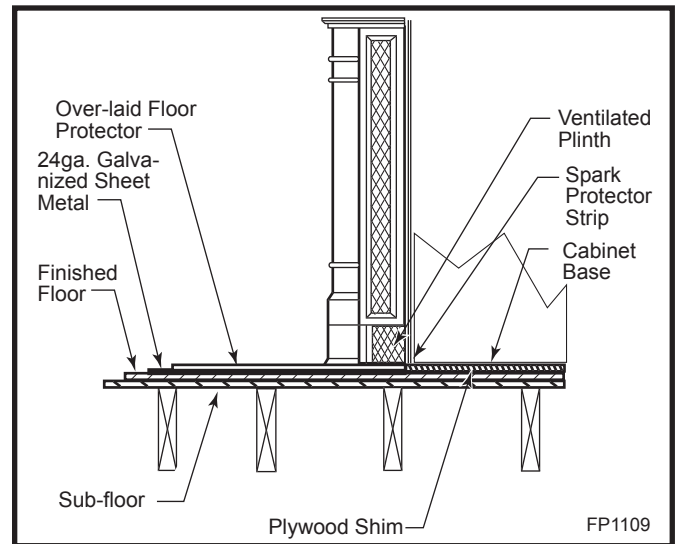
### Flush with the Floor or Laid Over It?

Generally, it is easier to lay floor protectors over the finished floor in existing homes. In new construction, flush installations are a popular alternative.

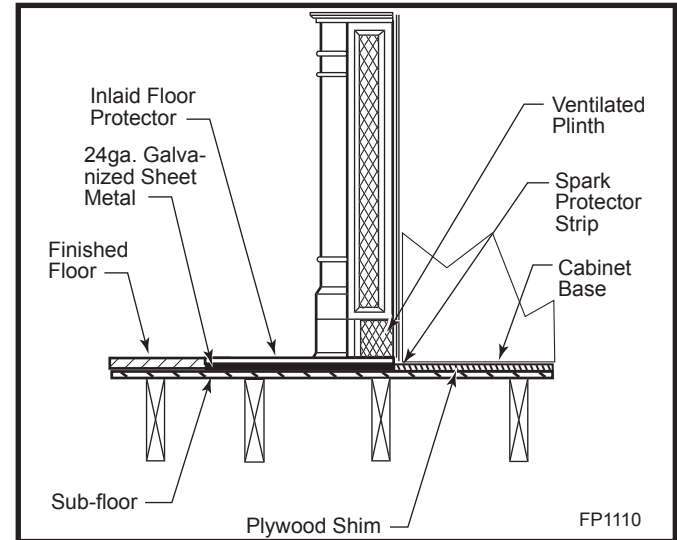
When placed over a finished floor, the floor protector extends completely under the ventilated plinth. (Fig. 32) The cabinet is elevated by an amount equal to the thickness of the floor protector so that the plinth and cabinet are at the same level. This is necessary for a proper fit between the WinterWarm front and the plinth. If you raise the cabinet more than 1" (25 mm), a corresponding increase in the height of the framed chase is required to retain adequate clearance.

When the floor protector is installed flush, the WinterWarm cabinet rests on plywood shimming that brings it level with the finished floor. (Fig. 33)

Whichever method you choose, the floor protector must satisfy the requirements outlined above, and the 3" x 38" (76 x 965 mm) sheet metal spark protector strip (included) must be laid under the junction of the cabinet and the ventilated plinth.



**Fig. 32** The components of a raised hearth. The floor protector is placed over the finished floor and extends completely under the ventilated plinth.



**Fig. 33** The components of a flush hearth. The floor protector is in-laid flush with the finished floor.

### Important Reminders:

1. **INSTALL ONLY AS ILLUSTRATED.**
2. Elevating the cabinet requires a corresponding increase in the height of the chase to retain adequate clearances. Refer to the chase specifications on Page 20 and double-check that all clearances will be satisfied.
3. The air inlet through the ventilated plinth must not be blocked.
4. A 3" x 38" (76 mm x 965 mm) strip of sheet metal (included in your Fireplace System) must be placed as a spark protector painted-side up underneath the joint between the front of the cabinet and the ventilated plinth.

## Electrical Requirements

The WinterWarm Cabinet has a removable junction box located on the bottom front corner of the left side. This enables the wiring to be completed before the cabinet is installed if desired.

The junction box houses two receptacles, one for the WinterWarm column fans and the other for the optional cabinet blower. The cabinet blower is especially recommended when the WinterWarm will be installed in a confined area that requires additional heat circulation. A 115V, 15 or 20A electric service line is required. If installing the optional cabinet blower, decide on the location for the blower control switch and mount a standard single-switch box to the chase framing.

## Customizing the Finished Appearance

The Trim Panels supplied with the WinterWarm System fasten the cabinet to the chase framing and give a finished appearance to the gap between the WinterWarm and the cabinet. They also provide a noncombustible transition surface to join with the combustible wall finish material, which must not extend inside the combustible limits.

The trim panels may be used without additional facing material, or with a surface to complement a specific decor.

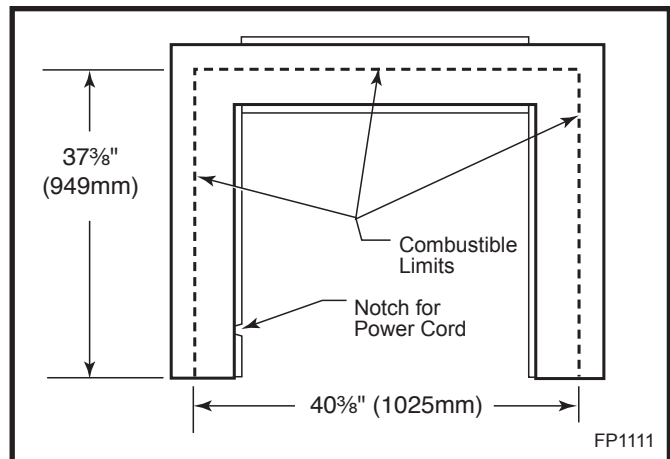
Many attractive, noncombustible finish materials can be applied over the trim panels, including veneer brick, tile, stone and plaster. The limitations are:

- The materials must be noncombustible.
- Their maximum thickness, including noncombustible backing and adhesive, should not exceed 13/16" (20 mm).
- Combustible edge molding must not protrude into the room more than 2" (51 mm) from the panel surface.
- To allow insertion of the fire box, the opening must be at least 33 1/4" (845 mm) wide, and 29" (737 mm) high. To ensure coverage of the trim inner edges by the installed WinterWarm fire chamber, the opening must be not more than 35 1/4" (895 mm) wide, and 33 1/4" (845 mm) high. Figure 25 demonstrates these dimensions.

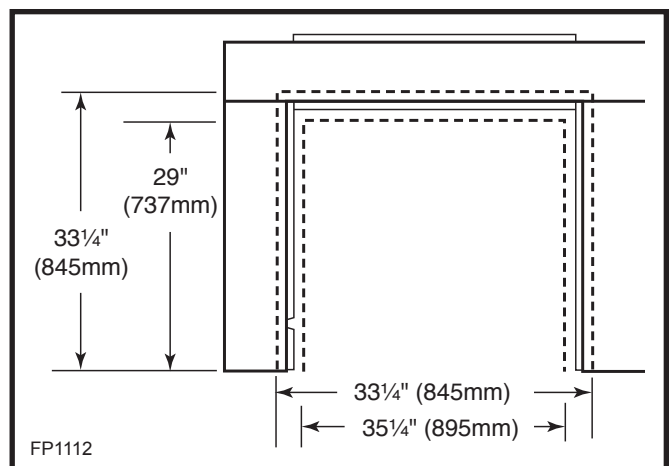
## Choosing a Facing Material

A variety of alternative facing materials can be used to enhance the fireplace. Bear in mind, however, that the total maximum thickness of any trim material, including backing materials and adhesive is 13/16". Here are a few possibilities: (Refer to Figures 34-39 for detail.)

- Basic. The trim pieces, painted as desired, but otherwise unadorned.

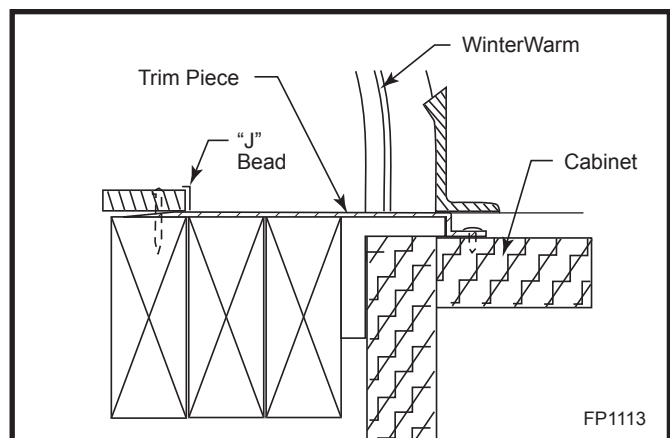


**Fig. 34** Keep combustible wall finish materials outside these limits.

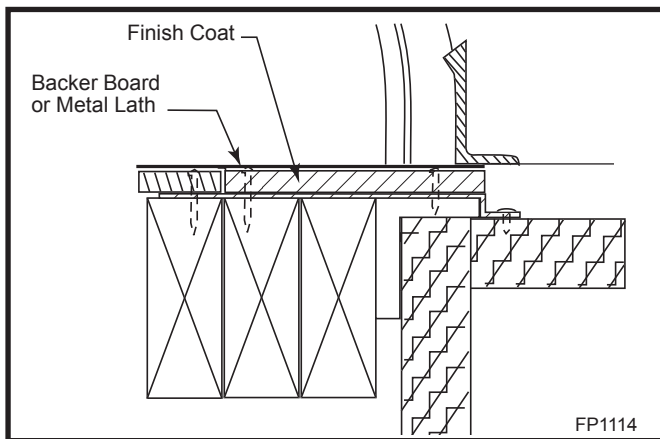


**Fig. 25** The fireplace opening must conceal the inner edges of the trim as well as accommodate the insert.

- Plaster. A finish skim coat of plaster may be applied over tile backer board or Wonderboard®, or over expanded metal lath and a scratch coat.
- Stone. Marble, granite, soapstone, slate, or other cut stone may be used. (Fig. 38) Stone may be ce-



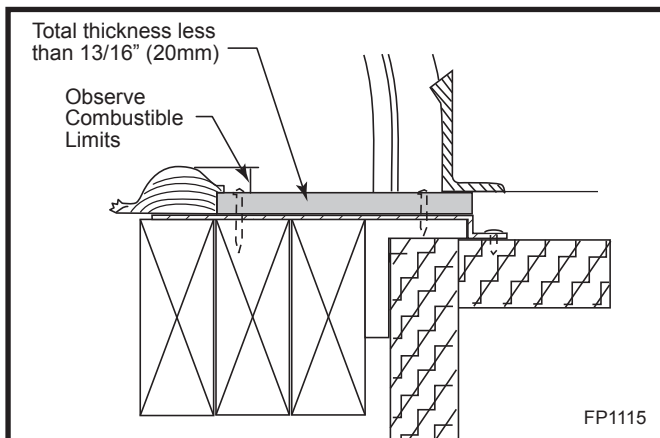
**Fig. 36** Top view of basic metal trim.



**Fig. 37** Top view of plaster flush-finished trim.

mented directly to the trim panels, or over noncombustible backing to shim it out relative to the finished wall surface. Be sure the height of the side pieces is between 29" (740 mm) and 33¼" (845 mm), and that the thickness of backing, adhesive, and stone combined is not more than 13/16" (20 mm).

- **Tile.** There are many tile options from which to choose. Here is one method of determining a satisfactory arrangement:



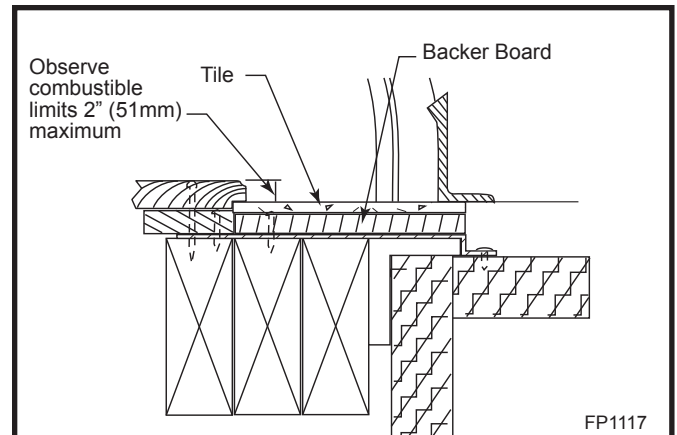
**Fig. 38** Top view of stone facing material and wooden (combustible) trim cemented directly to a noncombustible backing. The trim must protrude no more than 2" (51mm).

1. Draw the maximum and minimum fireplace opening dimensions on a large sheet of cardboard.
2. Place it on the floor and experiment with laying the tiles around the opening, varying within the limits to determine the best arrangement.
3. Trace and cut out a silhouette of the insert. Lay it over the tiles to show how the insert will cover the tiles when it is installed.
4. On another large piece of cardboard, cut an opening to represent the limits for combustible material, and position that on top of the tile layout. Keep in mind that while combustible material must not be brought inside the combustible limits,

it is entirely permissible to extend noncombustible facing materials beyond those limits to achieve a particular decorative effect.

5. Despite the most careful planning and the latitude provided by the maximum and minimum opening dimensions, it still may be necessary to cut some tiles to achieve a balanced appearance. Your tile supplier or local tool rental outlet should be able to supply the necessary equipment and explain how to use it properly.

Consult your Vermont Castings dealer for advice and suggestions for this process.



**Fig. 39** Top view of tile and wooden (combustible) trim installed over backer board.

### Use the Right Adhesives

The adhesive must be suitable to the chosen material and have a temperature rating of at least 400°F (204°C). High temperature silicone is an example.

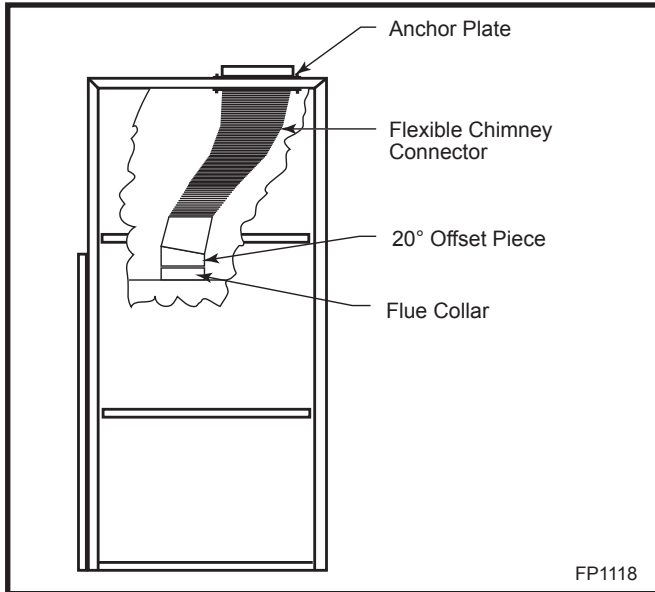
### Maintain a Safe Clearance to the Mantel

The clearance to the mantel and/or top trim must be at least 43" (1090mm), measured from the finished hearth surface. This clearance cannot be reduced by adding shields.

## Prepare and Install WinterWarm Cabinet

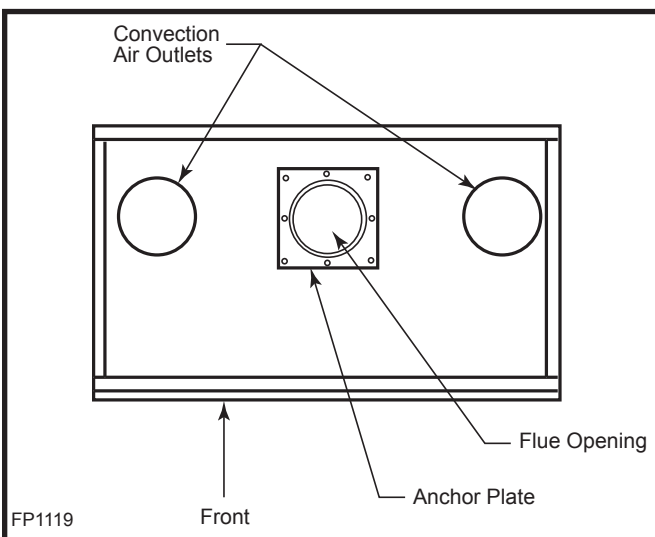
### 1. Unpack the carton.

**2. Install the flex connector.** Install the flex connector and attached flue flange to the underside of the cabinet top using eight #10-1/2" hex head sheet metal screws. The connector should point forward with the long axis of the oval running from side to side. (Fig. 40)



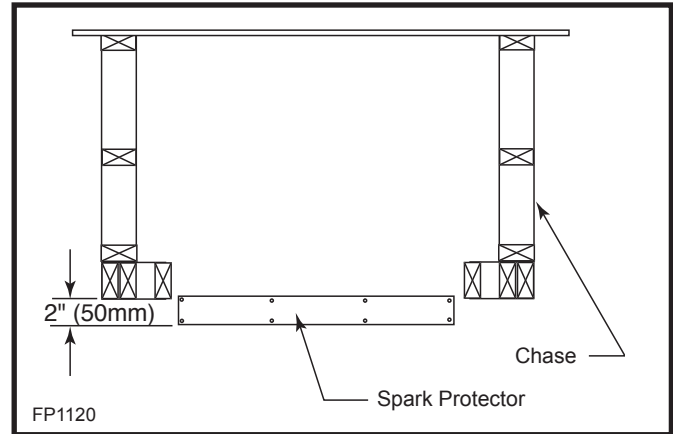
**Fig. 40** Proper position of the chimney connector, offset slip piece and anchor plate.

**3. Mark and drill the anchor plate.** Fit the chimney system anchor plate appropriate to your chosen pre-fabricated chimney over the flue outlet at the top of the cabinet and mark the attaching hole centers; remove the anchor plate and drill the fastener holes. (Fig. 41) Do not install the plate at this time.



**Fig. 41** The anchor plate mounts on top of the cabinet and secures the chimney to the chimney connector.

**4. Install the spark protector strip.** To install the 3" x 38" (76mm x 965mm) spark protector strip, first draw a line on the hearth parallel and 2" (51mm) in front of the chase opening. Center the spark protector strip in the chase opening, with the outside edge on the line. Nail or screw the strip down, painted side up, so that the fastener heads are flush with the surface of the spark protector strip. (Fig. 42)

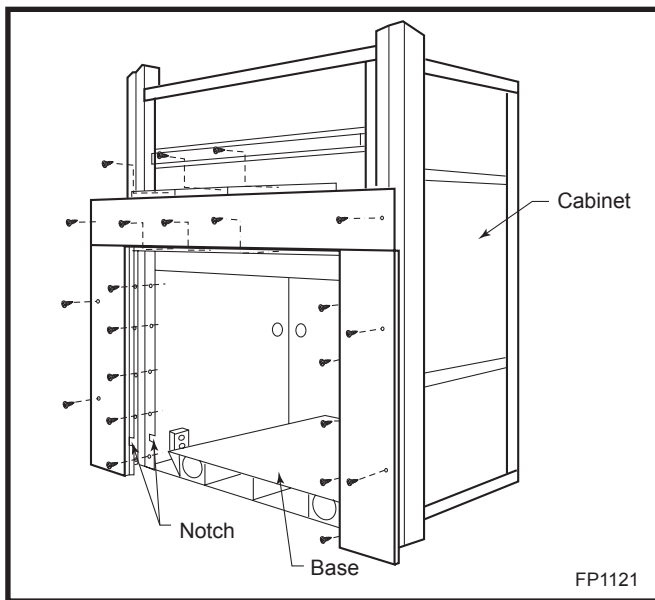


**Fig. 42** Install spark protector.

**5. Attach the trim pieces to the cabinet.** (Fig. 43) The parts supplied for this procedure include 16 sheet metal screws and one each of the following: an upper trim panel, a left trim panel and a right trim panel. You will also need an electric drill equipped with a 1/8" (3mm) bit and a 5/16" (8mm) head driver, and a felt tip pen for marking.

- Align the 5 holes in the left trim panel with the corresponding holes in the left edge of the fireplace opening on the cabinet. The notch in the flange should align with the notch in the cabinet front, approximately 4" (102mm) from the bottom.
- With the electric drill and the hex head driver, secure the trim panel using 5 of the hex head sheet metal screws provided.
- Repeat this procedure to install the right panel.
- Position the upper trim panel on top of the side panels and centered on the face of the cabinet.
- With the felt tip pen, mark through the 3 holes on each flange of the upper trim panel on the cabinet, and drill 1/8" (3mm) holes. Secure the panel to the cabinet with 6 sheet metal screws.





**Fig. 43** The trim panels fasten the cabinet to the chase framing and give the installation a finished appearance.

**6. Move the cabinet into the chase and fasten the trim panels to the chase framing.**

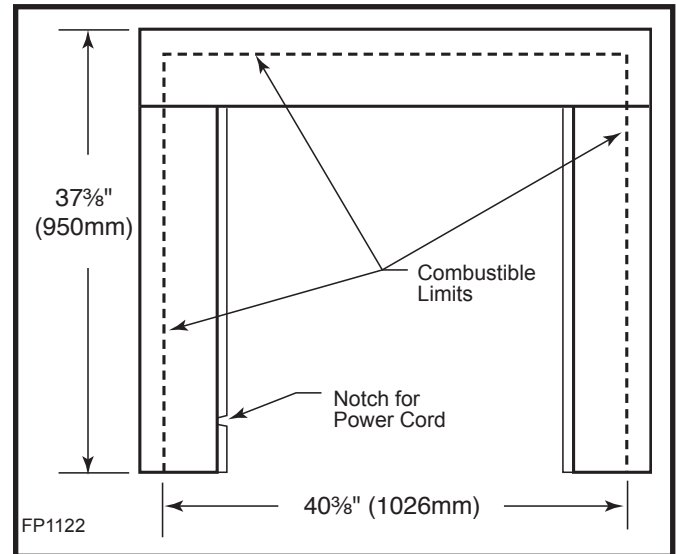
**NOTE:** The chase floor must be the same height as the hearth and must provide uninterrupted support. Push the cabinet carefully into the chase opening until the ends of the upper trim panel and the outer edges of the side panels rest against the studs forming the front of the chase. **IMPORTANT:** If the cabinet does not slide easily into position, **DO NOT** force it; doing so could damage the “standoffs” that ensure adequate clearance from combustibles. Instead, double-check your framed chase dimensions before proceeding to make sure you have allowed enough clearance.

**WARNING: DO NOT PACK REQUIRED AIR SPACES WITH INSULATION OR OTHER MATERIALS.**

- a. Attach the upper trim panel. Refer to the combustible limits illustration and the required dimensions, and locate one hole through each end of the upper panel into the studding behind. Make sure the holes are located outside the combustible limits where they will be hidden by wall covering or additional facing material. Drill the holes, check carefully for square one last time, and secure the panels with drywall screws driven home to make flush with surface.
- b. Attach the side panels. Drill 2 holes in each side panel, also outside the combustible limit, and secure the panels to the studding with additional drywall screws.

**NOTE:** Drywall or other combustible wall covering applied to overlap the outer edge of the trim panels **MUST NOT** extend inside the combustible limits. These limits also apply to any combustible edge molding used to trim the raw edge of the drywall.

In addition, combustible edge molding must not protrude into the room more than 2” (51mm) from the panel surface.



**Fig. 44** Make sure you secure the ends of the upper trim panels to studding located outside the combustible limits.

- c. After the cabinet has been installed to its proper depth, check all standoffs once again for proper clearance. Screw the cabinet to the floor through the eight drilled holes with eight of the #10 Phillips pan head sheet metal screws provided.
- d. Connect the electric service cable to the cabinet’s junction box if the wiring has not previously been completed. (**NOTE:** Since the cabinet’s junction box is removable, the wiring can be done outside the cabinet either before the cabinet arrives or after it has been installed.)

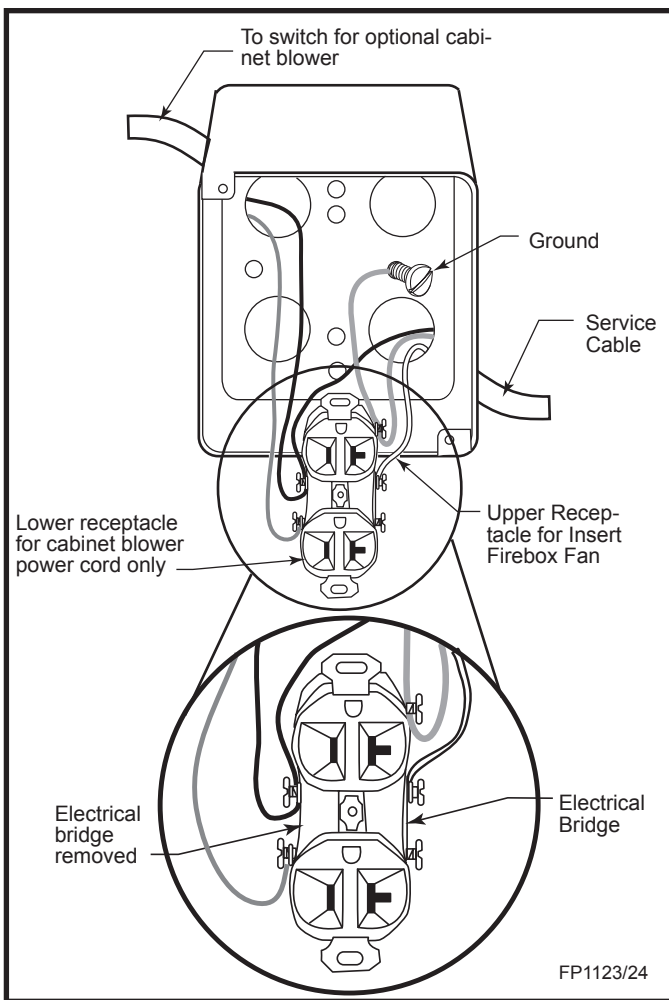
Remove the cover plate from the junction box in the cabinet. Pull the electric service cable (and the switch cable if installing the optional Cabinet Convection Blower Kit) into the cabinet junction box and wire the junction box as shown in the illustration below.

Figure 45 shows the required wiring for an installation using the optional cabinet convection blower kit. If your installation does not use the optional blower, **ONLY** the upper receptacle will be live.

Secure and tighten the strain relief.

- e. Install the required chimney anchor plate to the top of the cabinet. Use a 1/8” (4mm) bead of gasket cement to seal the flange to the cabinet. Install the chimney according to the manufacturer’s instructions; follow the instructions exactly.

**7. Install the air ducts.** Before installing the air duct boxes, you may wish to paint the inner surfaces with high temperature stove paint (or other high temperature paint) to reduce the glare from reflected light.



**Fig. 45** Wiring for an installation using the optional cabinet convection blower kit. When the kit is not used, only the upper receptacle is live.

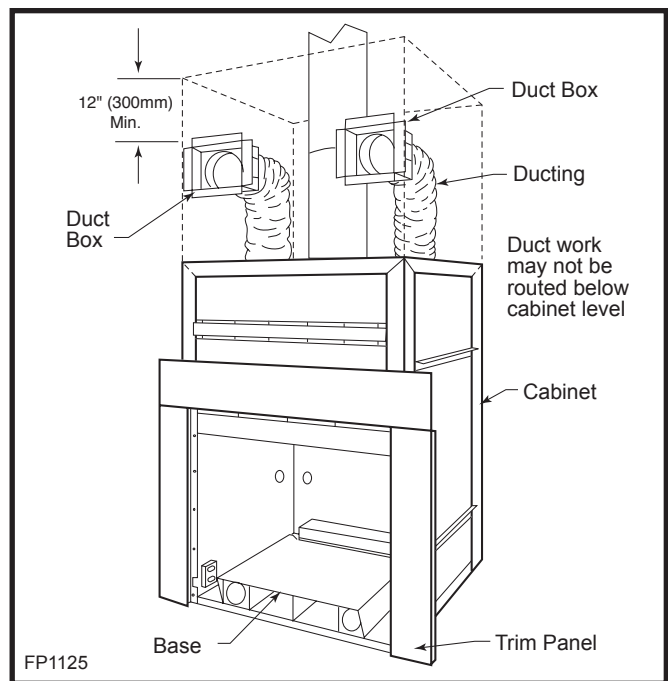
Install the two air duct boxes in their framed openings. (Fig. 46)

If desired, paint the inner surface of each air duct tube for about 6" (152mm) to eliminate reflected glare; attach this end to the air duct box flange.

Cut and fit the air duct tubing between the air duct boxes and the top of the cabinet. **NOTE:** The ducting used to connect the duct outlets on the enclosure cabinet to the remote duct boxes is Class O/Class I. Use no other class of ducting for this application. In certain areas, local building codes may prohibit the use of flexible ducting in enclosed spaces. In such cases it is acceptable to use solid cutting that meets local code requirements.

Cut the tubing a few inches too long with a serrated kitchen knife - it can be compressed during installation. The duct tubing must fit onto both the duct box and the cabinet flanges the full length of the flanges 2" (51mm)-all the way around.

Secure each end of the ducting to the appropriate flange with three of the sheet metal screws provided.



**Fig. 46** In addition to installation on the front, duct boxes may be mounted on the sides of the chase or vented into adjacent rooms, but in no case below the top of the cabinet.

Holes for the screws must be drilled first around the perimeter through both the duct tubing and the flange with a 1/8" (3mm) drill bit. Space the holes as evenly as possible around the flange.

**8. Install the elevated base.** Slide the base into the cabinet until it contacts the rear wall.

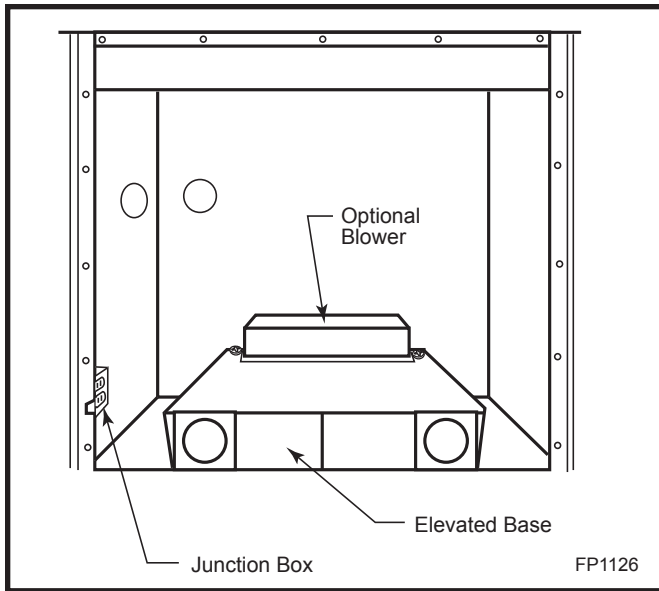
**9. Install the optional cabinet convection blower kit.** The blower kit is an integrated unit housed in a metal shell. ON the front side there is a flange perpendicular to the housing. When properly installed, this flange rests on the elevated platform and is fastened to it with screws.

The back side of the blower housing has a flange that rises parallel to the back side panel. This flange is fastened with screws to the rear panel of the cabinet.

The power cord is routed to the left where it can be connected to the lower receptacle of the cabinet junction box.

**10. Finish the wall surface surrounding the chase.** Cover the room's wall area surrounding the chase with a material of your choice, but carefully observe the noncombustible limits as described in Step 6b - drywall or other combustible wall covering applied to overlap the outer edge of the trim panels must not extend inside the combustible limits. These limits also apply to any combustible edge molding used to trim the raw edge of the drywall.

In addition, combustible edge molding must not protrude into the room more than 2" (51mm) from the panel surface.

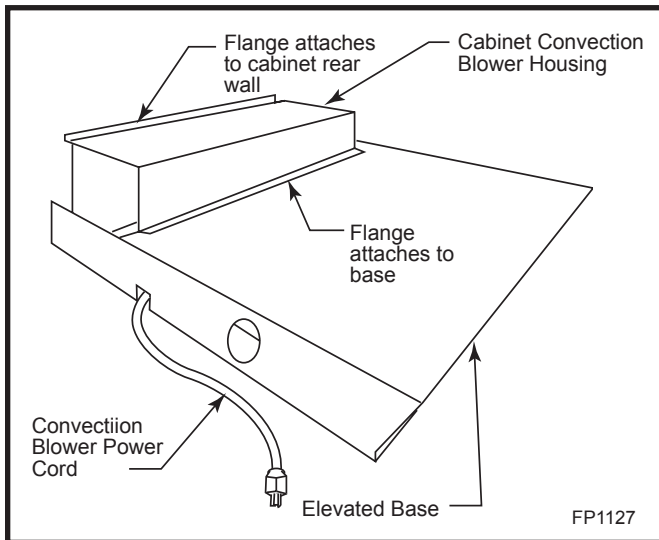


**Fig. 47** Slide the elevated base platform into the cabinet until it contacts the back panel.

Use drywall screws to fasten the wall covering to the metal standoff and drywall stops at the cabinet. Drill pilot holes through the wall covering material and one thickness of the sheet metal with a #40 (.098") drill bit. Tape and fill holes and/or seams and decorate your chase wall at this time.

**11. Install the vent grilles.** Position the cast grilles over the duct box openings, and mark for the four screw holes in each. Using a 5/32" (4mm) bit, drill through the drywall and duct box flanges, and install the grilles with the slot head black oxide screws.

Once the vent grilles have been installed, you are ready to complete the installation by installing the fire chamber and the front.



**Fig. 48** The cabinet convection blower in place behind the base.

## Section V: Completing the WinterWarm Installation

### Prepare and Install the WinterWarm Firechamber

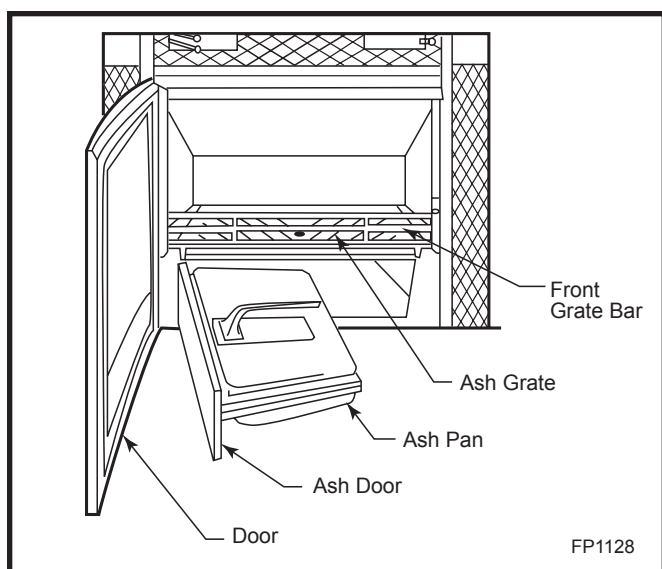
**1. Uncrate the WinterWarm Fire Chamber.** Uncrate the WinterWarm Firechamber and place it mounted on its shipping pallet about 24" (610mm) in front of its final destination — a masonry fireplace if you're installing the Fireplace Insert, or the cabinet if you're installing it as a part of the Fireplace System. (If the pallet height does not place the Fire Chamber slightly above the level of the cabinet's elevated platform in a Fireplace System installation, the pallet itself must be raised.)

The WinterWarm firechamber is shipped with the reversible flue collar in the rearmost position. The flue collar **MUST** be in this position for use in the Fireplace System.

**DO NOT REVERSE THE FLUE COLLAR ON THE FIRE CHAMBER IF YOU ARE INSTALLING IT INTO THE CABINET OF THE WINTERWARM FIREPLACE SYSTEM.**

Locate the damper control handle in the parts bag on top of the firechamber — it's the biggest of the three rods at 3/8" (9mm) — and screw it into place (refer to Page 3, Fig. 27). Lift up on the handle and move it to the left to open the damper. Open the fuel loading door. **NOTE:** The door will not open unless the damper is open.

Expose the levelling bolts (and lighten the Fire Chamber for easier handling) by removing the load door, the front grate bars, the ash grate, the ash pan, and the ash door. (Fig. 49)



**Fig. 49** Expose the levelling bolts by removing these parts.

**2. Install the Levelling Bolts.** Remove the two 5/16" (8mm) lag bolts that secure the WinterWarm to the pallet. Slide the WinterWarm forward on the pallet until the front levelling screw holes are accessible; screw in the missing front levelling screws (located in the finish bag). All four levelling screws should be positioned so they do not protrude below the plane of the shroud bottom.

**3. Install an Optional Probe Thermometer.** The WinterWarm is designed to accept a catalytic probe that monitors the temperature in the secondary combustion chamber. Your dealer can provide details on the probes that are available.

If you have purchased a probe, install it at this time. Remove the twelve hex head sheet metal screws that secure the WinterWarm shroud to its bottom panel and the two 1/4-20 hex head cap screws on the flue collar.

Remove the probe plug from the upper center of the cast WinterWarm back. Select a drill bit corresponding to the size of the probe you have purchased; spin the drill bit gently by hand through the exposed refractory material. Insert the probe carefully into the hole all the way to the probe's end. Route the probe lead right or left, but on top of the rib cast into the WinterWarm side, until the lead protrudes out the front. Replace and refasten the shroud and the flue collar.

**4. Install the Air Box of the Outside Air Kit.** The Outside Air Kit may be used with either the WinterWarm Fireplace Insert or the WinterWarm Fireplace System, and introduces outside air to the fire chamber for combustion. Outside air for combustion is especially desirable in some modern, super-insulated homes that have little air infiltration.

The kit consists of an air box, a 3" x 24" (76 x 610mm) air tube for Fireplace System installations, and a flange for connecting the pipe to the cabinet. The air box mounts on the left side of the fire chamber, and may be vented either from the rear or from the side.

**IMPORTANT:** When using the Outside Air Kit in a masonry fireplace installation, modifications to the fireplace may be necessary. Be sure to meet with your local building code inspector before beginning the installation to determine whether your plans meet code requirements. Contact your local Vermont Castings' Authorized Dealer for advice.

Adhere to the following guidelines when installing the outside air kit:

- Do not terminate the duct in a garage, attic, basement, or near another fuel-fed appliance.
- No portion of the outside air duct may be higher than the primary air inlet of the firechamber.

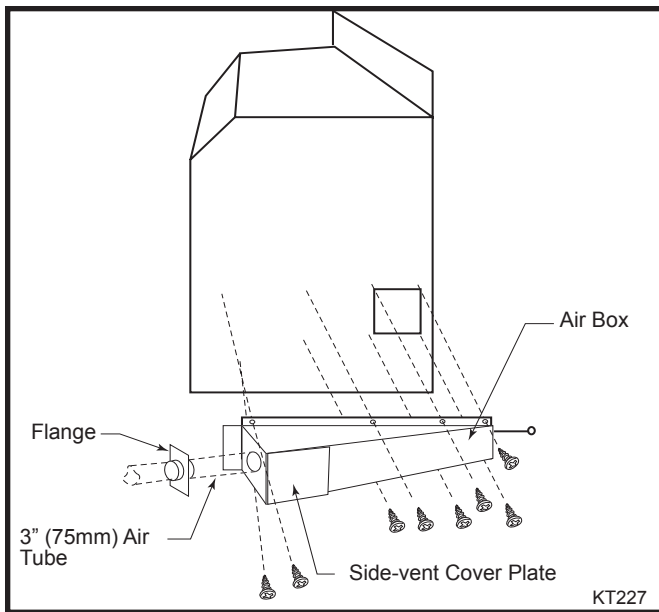
- The outside air duct's inlet must be lower than the primary air inlet of the firebox, to prevent air infiltration.
- The air inlet must be covered by a wire mesh screen with openings not larger than 1/4" x 1/4" (6 x 6mm) to prevent rodents entering from the outside.

a. With the WinterWarm fire chamber on its shipping pallet in front of either the fireplace or the installed Fireplace System Cabinet, remove the four (4) screws holding the outside air cover plate to the left side of the WinterWarm shroud. You may discard the cover plate, but save the four screws.

b. (Fireplace System only) Remove from the cabinet the cover plates over the air supply port you will be using; leave the other port sealed.

There is an inner and an outer plate for each port, each held in place by four sheet metal screws. The rear port is located on the lower left section of the cabinet's rear panel, while the side port is on the left panel of the cabinet. Cut the insulation out of the uncovered hole with a sharp utility knife. You may discard the plates, but save the screws.

c. The outside air duct is shipped with a cover plate over its access port for side venting. If your installation will be side venting, remove the cover plate from the side of the air duct and re-fasten it over the rear-venting access port. (Fig. 50)



**Fig. 50** The outside air duct box may be vented to the rear, as shown here, or from the side.

d. Position the Outside Air Duct against the left side of the shroud so that its control rod extends to the front. The rod must be passed through the latticework panel when you install the front. (Refer to Page 32, Step 7)

e. Loosely fasten the air duct to the shroud with two screws (one upper front and one lower rear). Place a level on the Outside Air Duct and level it before tightening these two screws.

f. Mark on the shroud the locations where you will drill the four remaining holes to fasten the Outside Air Duct (two upper and two lower holes). Remove the duct from the shroud and drill holes in the shroud with a 1/8" (3 mm) drill bit. Install the Outside Air Duct on the shroud using a total of eight screws. Check the level of the Duct once more before tightening the screws.

**5. Move the Fire Chamber all but a few inches into its installed position.**

**FIREPLACE SYSTEM ONLY:**

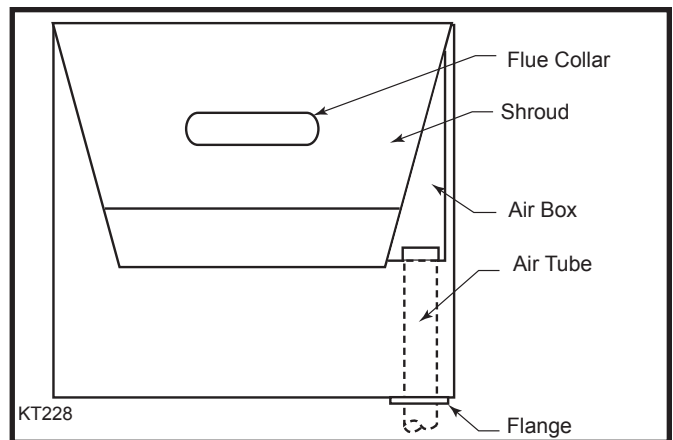
Push the Fire Chamber into the cabinet, leaving about 2"-3" (51 - 76mm) between the upper shroud flange and the front face of the cabinet. Remove the pallet.

**6. Connect the Outside Air Duct to the Air Box.**

**FIREPLACE SYSTEM ONLY:**

After final installation of the WinterWarm into the cabinet, slide the outside air duct into the 4" (102mm) diameter access port either in the rear or on the side of the cabinet (depending on your preferred location for the outside air delivery system), orienting the duct parallel to the floor. (Fig. 51) Continue to insert the duct until its crimped end plugs into the corresponding port in either the rear or the side of the air box. Attach the air duct flange to either the rear or the side of the cabinet with the four remaining screws.

Complete the outside air adapter installation by securing the flange to the pipe. Drill 1/8" (3mm) holes in the pipe through at least two of the four flange holes and secure with sheet metal screws.



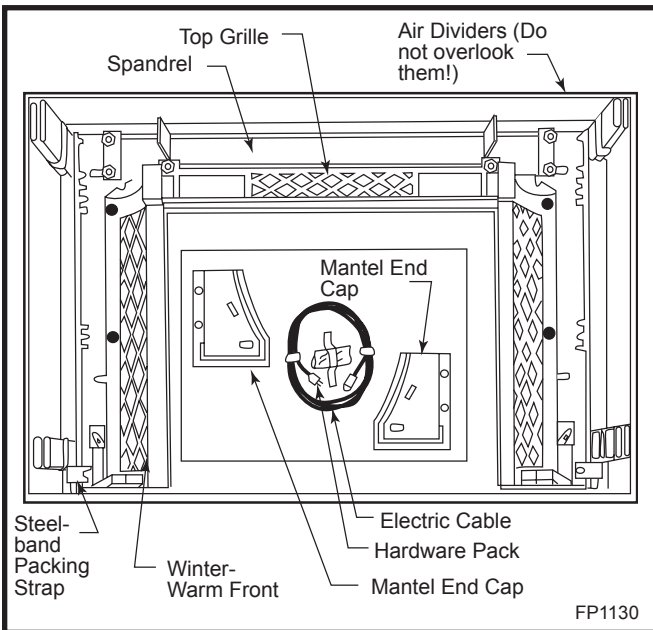
**Fig. 51** The final connection of the outside air duct to the air box is made once the fire chamber is in its final position.



## Prepare and Install the WinterWarm Front

Do not remove the WinterWarm Front from its shipping container until the directions indicate to do so. The installation of the front is much easier if you partially assemble some of the components before removing it from the container.

Refer to the Figure 52 for the location in the shipping container of the various parts. Also clear a “grab-space” nearby where you can keep handy the tools you’ll be using (Phillips-head screwdriver, 11/32” (9mm) wrench, 7/16” (11mm) wrench, 9/16” (14mm) wrench and utility knife) as well as the various parts you’ll be removing.



**Fig. 52** The WinterWarm front and its related parts are shown here after three separate boxes containing the mantel and latticework panels have been removed. For easiest assembly and installation, follow the sequence of the directions exactly.

**1. Open the Shipping Container.** Remove the straps securing the shipping container and then remove its top. Among the parts you’ll see in the box is the WinterWarm front (lying face down) a bubble-pack of parts, and boxes containing the mantel and latticework panels. To orient yourself for the following directions, stand so that the bubble pack is nearest your feet and the solid top cross-piece of the front (the “spandrel”) is farthest away.

**2. Unpack the Mantel, Latticework Panels, and Air Dividers.** Remove the large box on top containing the mantel, and the two boxes beneath it containing the latticework panels, and set them aside. Also remove the two air dividers that are packed in the edge of the carton next to the top of the front.

**3. Loosen the Bolts in the Spandrel and the Top Grille.** The solid top cross-piece of the front (the “spandrel”) is attached to the column sides with four bolts, two per side. Also, the top grille of the front is secured to the spandrel with two bolts. These fasteners should be loosened (not removed) while installing the front so that it will be easier to align the sides. These bolts must be re-tightened once the sides are in their permanent position.

**4. Remove the Packing Straps and Discard Them.** These flat steel bars are secured by one bolt on each side to the base of the column. Once you have removed the bolts, lift the top of the WinterWarm front and drag it slightly forward until it rests on the edge of the shipping carton. This will create enough room in the carton to slide the packing straps off the bottom of the front column. The packing straps will not be used again and may be discarded.

**5. Unpack the Remaining Parts.**

Slice open the bubble pack with your utility knife and remove the electric cord, the hardware package, and the two mantel end caps.

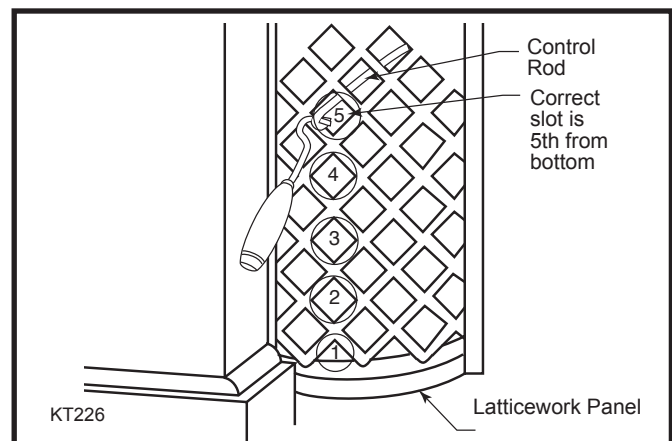
Open the boxes containing the mantel and latticework panels and remove the contents. Set all of these items aside.

**6. Empty the Contents of the Hardware Package onto your Grab Space.**

**7. Attach the Front to the Fire Chamber.**

With assistance, lift the front into position against the Fire Chamber, starting with the left side. Move it behind the protruding load door hinge halves. Swing the right side into position.

It may be necessary to adjust one of the levelling screws to align the clevis of the front to the fire chamber.



**Fig. 53** To find the correct space in the latticework panel for the outside air control rod, locate the second vertical row of “diamonds” from the left and count five spaces up from the bottom.

If you have installed the optional outside air kit, pass the control rod through the latticework at this time. (Fig. 53)

Seat the front against the Fire Chamber assembly, and attach with the six 1/4-20 X 3/4" (19mm) hex head cap screws and washers that are provided. There are two for each side and two for the top.

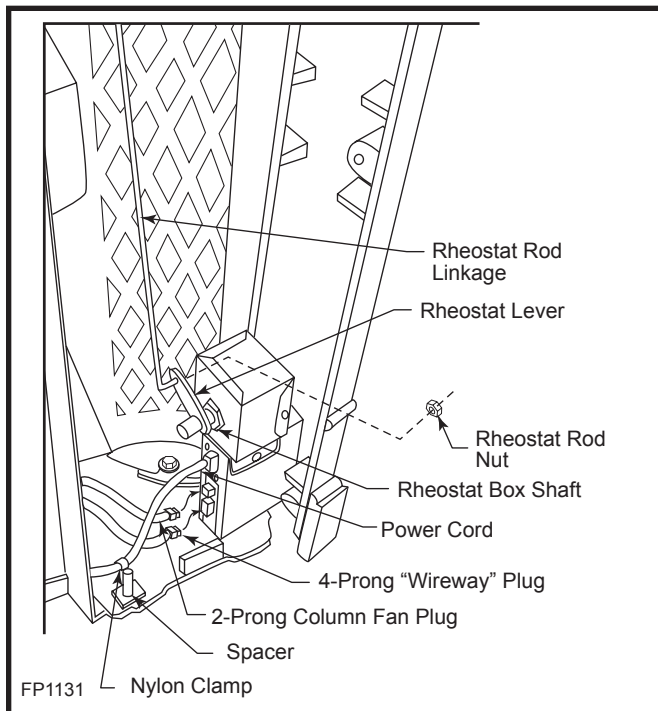
Make sure the front seats properly before tightening the cap screws; the edge of the front should be almost even with the side and top plates, protruding no more than 1/16" (2mm).

Tighten the left and right sides before tightening the top screws. Tighten the cap screws that attach the upper grille. **NOTE:** If the front has been installed too far forward, the door gasket may not make the required seal and the fire may be difficult to control.

### Step 8. Attach the Rheostat Rod Linkages

Untape the rheostat linkage rod from the left side of the firechamber. Remove the nut from the threaded end. Insert the rod end into the drilled hole in the rheostat lever. The rheostat box is located on the inside of the left front column. Thread the rod nut back on and tighten.

**NOTE:** The rheostat lever must be tilted towards the outside of the left column in order to attach the nut. After connecting the linkage, the lever must be tilted towards the inside of the column before installing the left column air divider. It remains in this inside position during operation. (Fig. 54)



**Fig. 54** The rheostat lever must be tilted first toward the outside of the left column to attach the nut, and then tilted toward the inside of the column before installing the left column air divider.

### 9. Connect the Wiring.

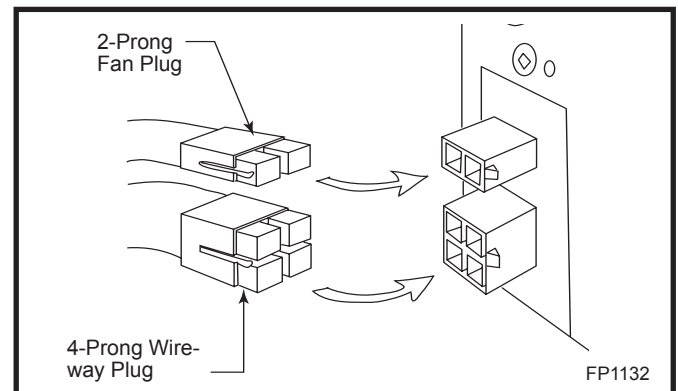
The two-pronged cable for column fans and the four-pronged wireway cable connect to the metal wire boxes on each side of the front with snap connector plugs, two on each side. The power cord must be plugged in as well.

First expose the receptacle for the power cord by removing the metal plate on the wire box. It is secured by two Phillips pan head machine screws. Also remove the nylon cord set clamp from the top of the spacer on the left wire box, and lay it aside for completing this step.

**NOTE:** The power cord always connects to the wire box on the left side in Fireplace System installations. For Fireplace Insert installations, it may connect to the wire box on either the right side or the left.

Next, plug the power cord into the wire box receptacle. Secure the cord by slipping the nylon cord set-clamp over the cord and fastening it to the top of the spacer with a 1/2" (13mm) Phillips pan head machine screw. For Fireplace Insert installations that have the power cord connected to the right side, mount the nylon cord clamp and spacer on the right wire box rather than the left.

Connect the two-pronged column fans plug and the four-pronged wireway plug to the wire boxes on both the right and left sides. (Fig. 55)



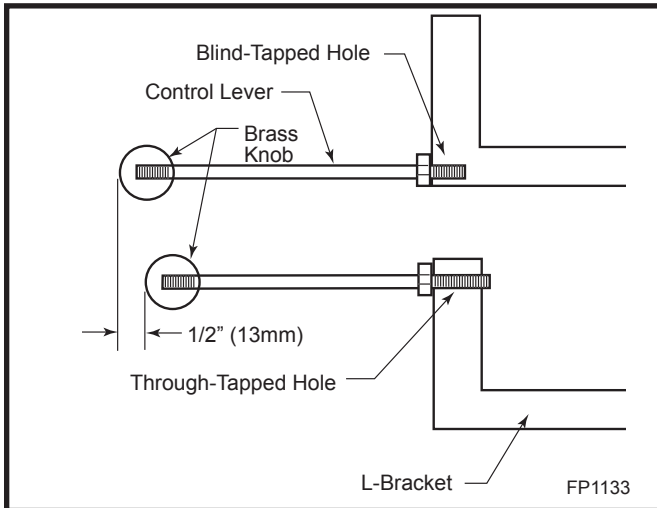
**Fig. 55** The snap connectors only fit their respective sockets.

Plug the power cord into its electric service receptacle, either a wall outlet in Fireplace Insert installations, or into the cabinet junction box in Fireplace System installations. **FIREPLACE SYSTEM NOTE:** Remember, connect the power cord to the UPPER receptacle in the cabinet junction box. The lower receptacle will not be live unless you are using the optional Cabinet Convection Blower Kit.

If you are unsure of how to make any of these connections contact your local Vermont Castings' Authorized Dealer.

### 10. Install and Adjust the Controls.

The rods that operate the WinterWarm's primary air, fan, and damper should be installed before mounting the column capitals and mantel. Two of the rods are 1/4" (6mm) and are controls for the fan and the primary air. The third rod is 3/8" (9mm) and controls the damper. Install the rods by following this procedure: (Fig. 56)



**Fig. 56** Adjust the controls so the primary air control rod, on the top, overhangs the fan control rod by 1/2" (13mm)

- Check for proper position of the hex nuts on the threaded rods. The larger hex nut on the 3/8" (9mm) diameter rod should be positioned all the way to the end of the thread on the longer of the two threaded ends. The two smaller hex nuts on the 1/4" (6mm) rods should be positioned as follows: One should be positioned as far up the thread as possible; the other should stop approximately 1/2" (13mm) from the end.
- Install the fan control rod by inserting the 1/4" (6mm) diameter rod with the nut all the way at the end of the thread into the bottom control lever on the WinterWarm's left side. Install the rod all the way up to the nut.
- Tighten the hex nut against the lever.
- Thread the two remaining control rods into the remaining two control levers. The lever above the fan control accepts the remaining 1/4" (6mm) rod; this is the primary air control. The lever on the right side of the WinterWarm accepts the 3/8" (9mm) rod; this is the damper control.

When installing the damper rod, look from above at the damper linkage. Note that the linkage should be flexed towards the rear. Make sure the linkage is in this orientation. The damper will not operated properly with the linkage flexed to the front.

- Thread each rod into the lever until it reaches the nut.

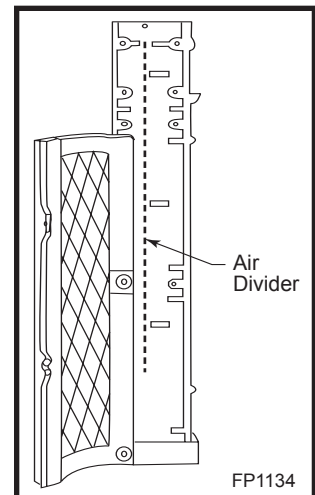
- Tighten the two hex nuts against the levers. The primary air and fan controls will be offset 1/2" (13mm) to allow for smooth adjustment.

### 11. Install the Air Divider.

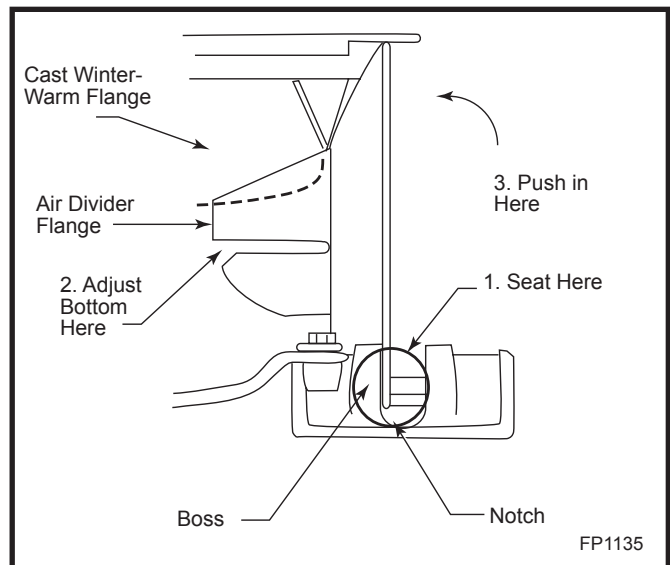
Install the two vertical sheet metal air dividers which guide the incoming and outgoing convection air. (Fig. 57) They are not interchangeable: the curved flange goes downward and faces the firebox. The two punchouts go toward the front.

Angle the front edge into position in the notch at the top of the column, while guiding the curved flange at the bottom so that it slides in on top of the curved horizontal flange that is cast into the firebox side.

The top edge of the air



**Fig. 57** Seat the entire length of the air divider in the notch between the bosses shown here as a dotted line.



**Fig. 58** 1. Seat entire length of air divider in notch. 2. Adjust the seated air divider so its bottom flange is just above cast flange of WinterWarm. 3. Push the opposite side of the air divider so it snaps into place.

divider must be flush with the top of the boss in the cast column, as shown in the circled area in Figure 58.

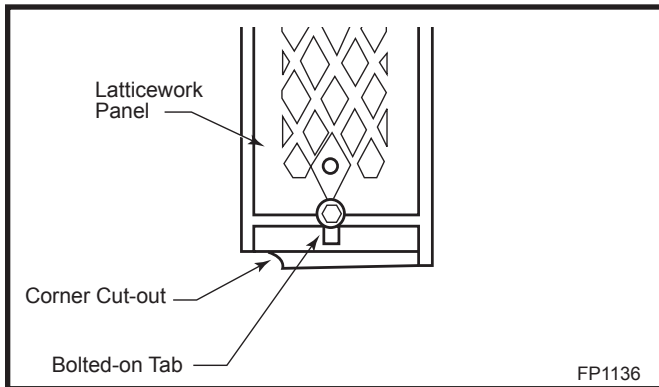
Push the rear edge in until the air divider is perpendicular to the column.

**12. Move the Entire Unit the final few inches into the Cabinet.**

Move the WinterWarm the final few inches into the cabinet, making sure the surround panels are properly aligned. If you are using the CFM Corporation Flex Connector System, reach up into the flue collar area to grasp the Starter Piece and pull it down into the flue collar. Bend the retaining tabs 90° against the bottom of the flue collar.

**13. Install the Latticework Panels.**

The two panels are not interchangeable. Each is labeled with a designating letter cast into the iron next to the tab — “L” for left and “R” for right. The corner cut-outs must be positioned on the back edge. The panels are anchored at the bottom by a single tab that is bolted on. (Fig. 59) At the top, the panels are retained by the overhang of the mantel.



**Fig. 59** A single tab at the bottom anchors the latticework panel, while the top of the panel is held in place by the mantel overhang.

Lower the panel and seat it on the base so the anchor tab locks behind the rib cast in the base plate. Secure it in place temporarily by holding it or with tape until the mantel is installed.

**14. Install the Mantel.**

Place the mantel flat side down on the floor. Lift the mantel slightly and slip the drilled and tapped ends of the column capitals under each end of the mantel. Align the two tapped holes in each capital with the two holes in each end of the mantel, and thread in two 3/4” (19mm) hex head cap screws and two washers. Do not tighten these cap screws with a wrench; leave them finger tight. Use care during this assembly process, especially with enamelled parts. Forcing the mantel or capitals into position may cause chipping or cracking.

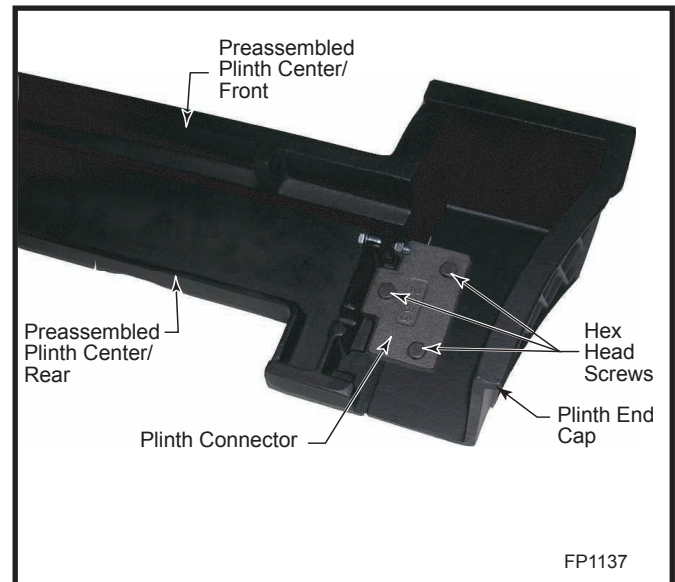
Install the mantel and capital assembly by raising it into position and tilting it to the rear against the upper shroud flange, with the flange on the shroud in front of the back rib on the mantel. Push against the flange slightly before lowering the front edge of the assembly onto the upper trim piece.

**15. (Fireplace Systems only) Install the Plinth.**

The plinth assembly consists of a pre-assembled plinth center and front, two plinth end caps, two plinth connectors, and six hex head screws (1/4-20 x 1/2” (13mm)).

Invert the plinth center and front assembly on a flat surface. Unpack the two end caps and invert them also, placing one at each end. Make sure the decorative fronts of the end caps are in line with the front of the plinth. (Fig. 60)

Place the stem end of the plinth connector on the plinth



**Fig. 60** Before attaching the end caps, make sure their decorative fronts line up with the front of the plinth.

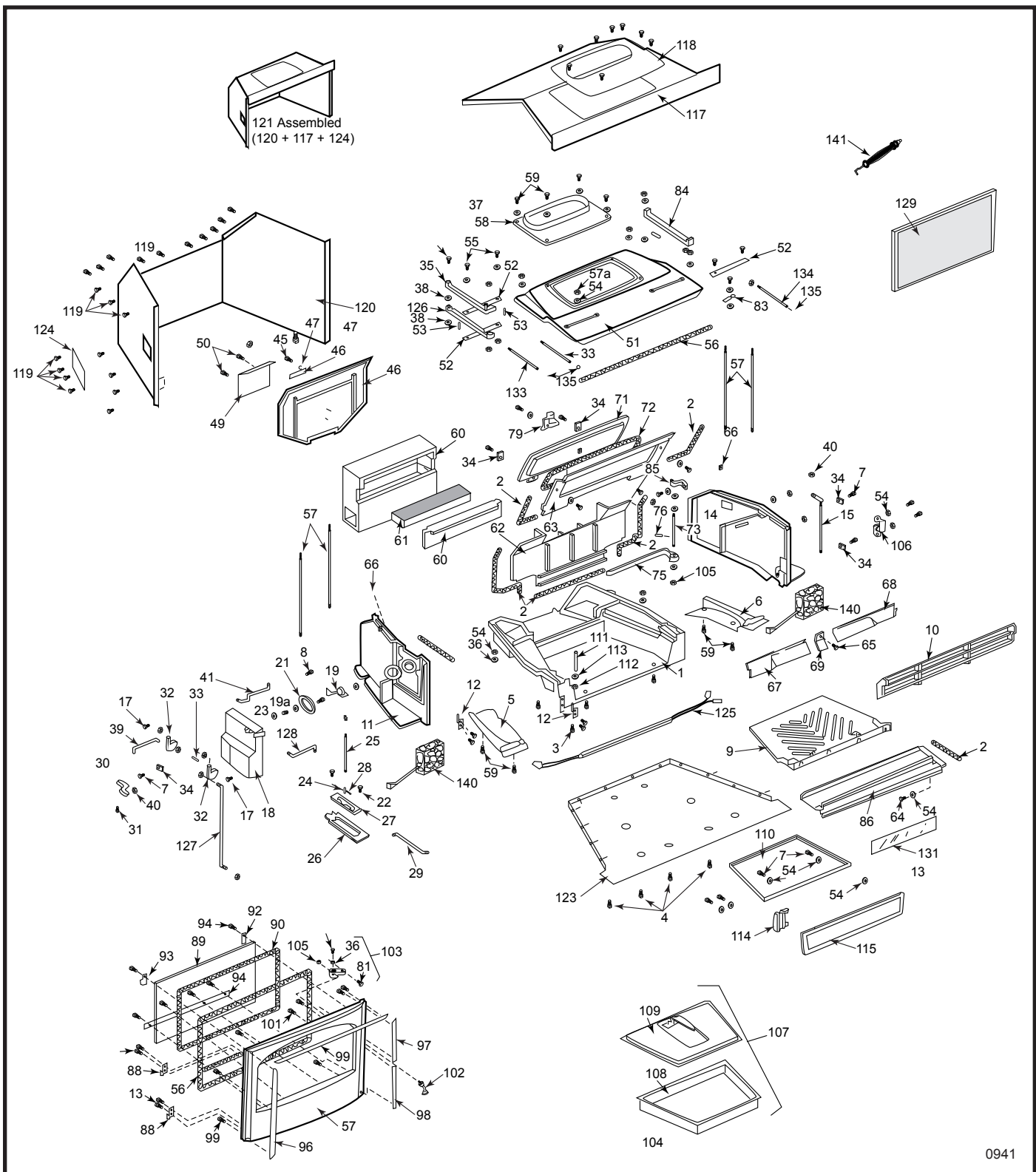
with the connector hole centered over the tapped hole in the plinth. The other two holes in the plinth connector should line up with the two tapped holes in the end caps. (If they do not line up, remove the plinth connector and flip it over.)

Repeat this process for the other side. Attach the plinth connectors with the six (6) hex head cap screws provided.

Set the assembled plinth in the upright position, in front of and centered on the WinterWarm. Adjust the levelling bolts on the bottom front of the fire chamber so that the plinth will fit, slide the plinth into its final position, and center it. Adjust the levelling bolts downward to lower the WinterWarm onto the plinth.

**Step 16. Replace the Ashpan and Ash Door, Front Grate Bars, Bottom Grate and Load Door.**





0941

CFM Corporation reserves the right to make changes in design, materials, specifications, prices and discontinue colors and products at any time, without notice.

# WinterWarm Large Insert

## Model 2100



# WinterWarm Large Insert

## Model 2100 (continued)

Item Description	Part Number
1. Bottom Only	1301150
2. 5/16 Fiberglass Medium Density (sold by the foot)	1203588
3. 3/8-16 x 2" Hex Head Leveller Bolt	1201742
4. 1/4-20 x 5/8" Phillips Flat Head Screw	1200865
5. Left Fan Heat Shield	1301151
6. Right Fan Heat Shield	1301152
7. 1/4-20 x 1/2" Hex Head Cap Screw	1201338
8. 1/4-20 x 1/2" Phillips Round Head Screw	1200894
9. Ash Grate	1301256
10. Bar Grate	1301275
11. Left Side Firebox	1301280
12. Half Hinge, Body Upper	1604281
13. 1/4-20 x 1/2" Hex Head Leveller Bolt	1201347
14. Right Side Firebox	1301264
15. Damper Door Interlock	1301299
16. Interlock Door/Damper Wire	1601568
17. 1/4-20 x 1 3/4" Phillips Flat Head Screw Black Primary Air Box Assembly (Includes Item #'s 7,8, and 18 thru 34)	1200830 5000343
18. Primary Air Box	1301281
19. Thermostat Assembly	5005470
19a. Friction Spring	1201846
20. Jump Ring	1201985
21. Thermostat Disc	1301269
22. 1/4-20 x 5/8" Phillips Round Head Screw	1200896
23. Washer, Flat 1/4 #304 SS .294 id x .63 od x .047 Thick	1202471
24. Ball Chain Fitting	1201972
25. #6 Nickel Ball Chain, 21 Balls, Attach Chain @ 19 Balls (sold by the foot)	1201960
26. Thermostat Valve	1301268
27. Thermostat Flap	1301265
28. 7/16 x 5/8" Cotter Pin	1203027
29. Thermostat Flat Wire	1604503
30. Thermostat Acuator	1301258
31. 1/4-20 x 1/4" Socket Set Screw	1200417
32. Bell Crank	1301263
33. Crank Pin	1600524
34. Damper Tab	1601488
35. Thermostat Control Arm	1301284
36. 1/4-20 Plain Hex Nut	1203210
37. 3/8-16 Threaded Should Bolt, 1/2 x 1 1/4" Body	1201319
38. Washer, Flat 1/2 SAE	1202491
39. Lower Thermostat Wire Link	1604501
40. #8-32 Hex Top Lock Nut	1203275
41. Upper Thermostat Wire Link	1604502
42. 5/16" Hole Plug	1201899
43. Firebox Back	1301251

Item Description	Part Number
44. Secondary Thermostat	1601489
45. 10-24 x 1/4" Phillips Pan Head Screw	1200980
46. Secondary Air Flap	1601490
47. Shim Ring, 18 Ga Nickel	1201986
48. Secondary Air Link	1601486
49. Secondary Air Coverplate	1604505
50. 1/4-20 x 3/8" Phillips Pan Head Screw	1200993
51. Firebox top	1301253
52. Control Shim	1604338
53. Control Spacer	1201781
54. Washer, Standard Flat 1/4 - Z .313 od x .742 od x .06 Thick	1202474
55. 1/4-20 x 1" Hex Head Cap Screw	1201326
56. Gasket, 1/2" Low Density Black (sold by the foot)	1203564
57. Tie Rod Set (includes 4 of 1601640 Tie Rods & 4 of 1203210 Plain Hex Nuts)	5007499
57a. 1/4-20 Top Lock Hex Nut	1203213
58. Flue Collar	1301276
59. 1/4-20 x 3/4" Hex Head Cap Screw	1201374
60. Refractory Assembly (Includes #1602511 Access Panel)	1602510
61. Catalyst (Old PN 1602505 in a carton)	30001152
62. Lower Fireback	1301252
63. Upper Fireback Upper Fireback & Damper Assy (Includes Items #7, 34, 36, 63, 65, 69 to 72, 79 to 82)	1301260 5000044
64. 1/4-20 x 1" Hex Head Cap Screw - Black	1201376
65. 1/4-20 x 1 1/2" Hex Head Cap Screw	1201386
66. 1/4-20 Nut Plate	1203105
67. Left Throat	1301296
68. Right Throat	1301297
69. Throat Clamp	1301298
70. 1/4-20 Square Nut	1203329
71. Damper	1301259
72. Gasket, 3/6" Low Density 6ND (sold by the foot)	1203589
73. Damper Operating Rod	1604522
74. Washer, Thick Flat .52 id x .875 od x .085 Thick	1202492
75. Damper Swing Arm	1301282
76. 3/16 x 1" Stainless Steel Damper Rod Pin	1201839
78. Washer, Flat 3/8 - Z .442 id x 1 od x .074 Thick	1202488
79. Damper Swing Arm Retainer	1301270
80. Washer, Narrow Flat 1/4 .275 id x .5 od x .063 Thick	1202475
81. 1/4-20 x 3/4" Socket Head Cap Screw	1200461
82. 1/4-20 x 1 1/4" Socket Set Screw	1200446
83. Damper Actuator Link Stop	1604507
84. Damper Actuator Link	1301283
85. Damper Rod Retainer	1301271
86. Door Air Manifold Door Assembly (Includes Item #'s 13, 56, 87 to 92, 94 to 99, 101, 102, 103, 105)	1301274 5006079

## WinterWarm Large Insert Model 2100 (continued)

Item Description	Part Number
87. Door	1301257
88. Half Hinge, Door (No pin) Upper	1604280
89. Glass Cassette (Approx. 22" x 13")	5002617
90. Gasket, 3/16 Fiberglass 4ND Black	1203556
91. Glass Retainer, Lower	1601403
92. Glass Retainer, Upper (2 required)	1601409
94. 10-24 x 3/8" Phillips Pan Head Screw	1200985
95. Brass Trim, Top	1402504
96. Brass Trim, Left	1402505
97. Brass Trim, Upper Right	1402507
98. Brass Trim, Lower Right	1402508
99. 8-32 x 1/2" Phillips Flat Head Screw	1202041
101. 8-32 x 1/4" Phillips Flat Had Screw (Upper Brass Trim -Center Screw)	1202045
102. Handle Stub Assembly w/Shaft, Gold	5004273
103. Pawl Assembly Short Adjustment	30002362
104. 1/4-20 x 3/16" Socket Set Screw	1200415
105. 3/8-16 Top Lock Hex Jam Nut	1203290
106. Striker Plate	1301273
107. Ash Pan Assembly (Includes Item #'s 108, 109)	5005746
108. Ash Pan Only	1601025
109. Ash Pan Cover with Handle	1601027
110. Ash Pan Bracket	1601039
111. Ash Pan Swing Pin, 3/8" od	1600523
112. 3/8-16 Hex Jam Nut	1203157
113. Washer, Narrow Flat 3/8	1202560

Item Description	Part Number
114. Ash Pan Door Clamp	1301272
115. Decorative Ash Door	1301277
116. 1/4-20 x 5/8" Hex Head Cap Screw	1201372
117. Shroud Top	1402445
118. Shroud Flue Connector Plate	1403363
119. #10 x 1/2 Phillips Pan Head Sheet Metal Screw - Black	1202058
120. Shroud Sides and Back Assembly	1402450
121. Shroud Assembly (Includes Item #'s 117, 120, 124, 119)	5000043
123. Shroud Bottom	1402448
124. Outside Air Cover	1402453
125. Wireway Assembly	5002779
126. Rheostat Contol	1301255
127. Lower Rheostat Wire Link	1604511
128. Upper Rheostat Wire Link	1604512
129. Spark Screen (Inserted in Door after removing glass cassette)	1206343
131. Listing Label, UL, ULC, EPA, Safety	N/A
133. Wire Handle 1/4" Diameter (Fans & Thermostat)	1604504
134. Wire Handle 3/8" Diameter (Damper)	1604514
135. Gold Ball for Wire Handles	1602470
140. Fan Assembly Fan Mounting Bracket	5002771 1601244
Silicone Suspension Tubes for Mounting Fans	1601245
Washer, Flat #10 SAE	1202423
8-32 Hex Nut	1203273
8-32 x 2" Round Head Slotted Screw - Z	1201243
141. Handle Package Fallaway	0004349

Shell Enamel Parts - WinterWarm Large Insert Model 2100			
Part Name	Classic	Sand	Midnight
Mantel	1301278	1321278	1341278
Left Cap	1301289	1321289	1341289
Right Cap	1301290	1321290	1341290
Outer Trim	1301303	1321303	1341303
Spandrell II	30001401	30001403	30001405
Column II	30001402	30001404	30001406

## Appendix: Approved Chimney Components

	American Metal Products Ameri-Tec Model HS	Condensation Engineering Corp. Vitroliner HS-2100	GSW Building Product Co. Model SC	Metal Fab, Inc. Model TG	Security Chimneys, Ltd. Model ASHT	Selkirk Metalbestos Model SSII	Simpson Dura-vent Dura-Plus
<b>Anchor/base plate</b>	8HS-AP	8H-SP	JSC 8 AP	8TG AP	8 SP	8T-AP	9201
<b>Starter</b>	NA	NA	NA	NA	NA	NA	9216
<b>Chimney sections</b>	8HS-6 8HS-12 8HS-18 8HS-24 8HS-36	8H-SCS36 8H-SCS24 8H-SCS18 8H-SCS12 8H-SCS6	JSC 8 SA3 JSC 8 SA2 JSC 8 SA1	8TG 36 8TG 24 8TG 18 8TG 12 8TG 6	8 L3 8 L2 8 L18 8 L1 8 L8	8T-36 8T-18 8T- 9 8T- 6 8T- 3	9206 9219 9214 9221/9221SS 9217/9217SS
<b>Elbows</b>	8HS-015 8HS-030	8H-SEL15 8H-SEL30	JSC 8 SE	8TG A15 8TG A30	8 E15 8 E30	8T-EL15 8T-EL30	9264 9266
<b>Firestops/shields</b>	8HS-AIS 8HS-FSA	8H-AJS 8H-RJS 8H-FJS 8H-WS	JSC 8 AIS JSC 8 FRS JSC 8 FAIS	8TG IS 8TG RSH 8TG FSA	8 RSA	8T-AIS 8T-JS 8T-WS 8T-TCS	9244 9946 9980A 9980B 9980C
<b>Storm collar</b>	8SC	8H-CSC	JSC 8 ASC	8TG SC	8 FC	8T-SC	9959
<b>Caps</b>	8HS-RES	8H-CRCA	JSC 8 DRC JSC 8 RC	8TG C 8TG RC	8 CPR 8 CC 8 CPE	8T-CT	9284
<b>Wall band</b>	8HS-SBA	8H-CGR	JSC 8 WB	8TG WB	8BM	8T-WB	9268/9268SS
<b>Flashings</b>	8F 8FT	8H-CFF 8H-CFLC 8H-CFM 8H-CFH 8H-CFS	JSC 8 ATC JSC 8 AAF JSC 8 AF2 JSC 8 AF3	8TG F 8TG 15 8TG F24 8TG FT	8F 8FPA 8FPB 8FA 8FB 8FBB	8T-TF 8T-AF6 8T-AF12 8T-AF24 8T-AF36	9251 9249 9250 9281 9252
<b>Supports</b>	8HS-CSA 8HS-RSA	8H-SSL9 8H-SRL9	JSC 8 DCS	8TG RS 8TG SB	8ST 8S	8T-RSP 8T-FSP	9262* 9260*  *Can only accept chimney above it, not below.

## Appendix: Catalytic Combustor

In any chemical reaction, including the combustion process, there are certain conditions which must be met before the reaction can take place. For example, a reaction may require a certain temperature, or a certain concentration of the reactants (the combustion gases and oxygen), or a certain amount of time. Catalysts, though not changed themselves during the reaction, have the ability to act at a molecular level to change these requirements. In the secondary combustion chamber of the WinterWarm, the catalyst reduces the temperature at which secondary combustion can start from the 1000 - 1200°F (540 - 650°C) range to the 500 - 600°F (260 - 315°C) range, increasing efficiency, and reducing creosote and emissions.

The catalytic reaction, though advantageous, does have some limitations of its own. Primary among these is that the reactants (the gases) come into close physical contact with the catalyst itself.

To ensure the necessary contact, the catalytic element in your WinterWarm is composed of a ceramic base in the shape of a honeycomb. On each of the honeycomb's many surfaces a coating of the catalyst (usually a noble metal such as platinum or palladium) is applied. The large surface area exposed in this configuration ensures the combustion gases have the greatest opportunity to come in contact with the catalyst.

Loss of catalytic activity will be apparent in several ways. First you may notice an increase in fuel consumption. Second, there will be a visible increase in the rate at which creosote builds up in your chimney connector system. You may also notice a heavy discharge of smoke from the chimney. There are a number of catalytic problems which can cause loss of activity:

### Blockage

While the honeycomb pattern ensures good contact, it also increases the resistance to flow of the combustion gases, and, because of the many surfaces, provides more places for creosote and fly ash to deposit. It is important to follow the operating instructions in order to minimize these deposits, and to periodically inspect your catalyst for signs of blockage.

### Masking and Poisoning

While the catalyst itself does not enter into the combustion process, it is possible for certain elements, such as lead and sulfur, to attach to the active sites on the surface of the honeycomb. Though the catalyst is still there, it is covered, or masked, by the contaminant, and cannot function. To avoid this situation, it is important not to burn anything in your WinterWarm that is a source of these contaminants. Particularly avoid painted or treated wood, coal, household trash, colored papers, metal foils, or plastics. Chemical chimney cleaners may also contain harmful elements. The safest approach is to burn only untreated, natural wood.

### Flame Impingement

The catalytic element is not designed for exposure to direct flame. If you continually overfire your WinterWarm, the chemistry of the catalyst coating may be altered, inhibiting the combustion process.

Thermal degradation of the ceramic base may also occur, causing the element to disintegrate. Stay within the recommended guidelines of the Operation section.

### Mechanical Damage

If the element is mishandled, damage may occur. Always treat the element carefully. Remember the catalyst is made of a ceramic material; treat it as you would fine china. Hairline cracks will not affect the performance of the catalyst, as long as the steel sleeve holds the element in the proper position.

### Peeling

Peeling of the surface coat may occur if the catalytic element is frequently subjected to excessive temperatures. Follow the operating instructions carefully to avoid this type of damage.

Every Vermont Castings' product is equipped with either a Corning "Long-Life"® or a Technical Glass Products "Honeycomb"®. The products are equivalent. If for any reason you must ship your catalytic element, remember its fragile nature. Place the element in a plastic bag, and package it with a generous amount of shock absorbing material.

# Warranty

## Limited 3 Year Warranty

**CFM Corporation warrants that this woodburning stove will be free of defects in material and workmanship for a period of three years from the date you receive it, except that the catalyst, thermostat assembly, handles, glass door panels, cement, and gasketing shall be warranted as described below.**

Products will repair or replace, at its option, any part found to be defective upon inspection by a CFM Corporation Authorized Dealer. The customer must return the defective part or the stove, with shipping prepaid, to the Authorized Dealer or pay for any Authorized Dealer in-home travel fees or service charges for in-home repair work. It is the dealer's option whether the repair work will be done in the customer's home or in the dealer's shop. If, upon inspection, the damage is found to be the fault of the manufacturer, repairs will be authorized at no charge to the customer for parts and/or labor.

Any woodburning stove or part thereof that is repaired or replaced during the limited warranty period will be warranted under the terms of the limited warranty for a period not to exceed the remaining term of the original limited warranty or six (6) months, whichever is longer.

### Limited 1 Year Warranty

The following parts of the woodburning stove are warranted to be free of defects in material and workmanship for a period of one year from the date you receive it: The thermostat assembly, handles, glass door panels, cement, and gasketing. Any of these items found to be defective will be repaired or replaced at no charge, upon the return of the part with postage prepaid to a CFM Corporation Authorized Dealer.

Any part repaired or replaced during the limited warranty period will be warranted under the terms of the limited warranty for a period not to exceed the remaining term of the original limited warranty or six (6) months, whichever is longer.

### Exclusions & Limitations

1. This warranty is transferable; however, proof of original retail purchase is required.
2. This warranty does not cover misuse of the this stove. Misuse includes overfiring which will result if the stove is used in such a manner as to cause one or more of the plates to glow red. Overfiring can be identified later by warped plates and areas where the paint pigment has burned off. Overfiring in enamel fireplaces is identified by bubbling, cracking, chipping and discoloration of the porcelain enamel finish. CFM Corporation offers no warranty on chipping of enamel surfaces. Inspect your woodburning stove prior to accepting it for any damage to the enamel.
3. This warranty does not cover misuse of the stove as described in the Owner's Guide, nor does it cover any stove which has been modified unless authorized by a CFM Corporation representative in writing. This warranty does not cover damage to the stove caused by burning salt saturated wood, chemically treated wood, or any fuel not recommended in the Owner's Guide.

4. This warranty does not cover a stove repaired by someone other than a CFM Corporation Authorized Dealer.

5. Damage to the unit while in transit is not covered by this warranty but is subject to a claim against the common carrier. Contact CFM Corporation Authorized Dealer from whom you purchased your stove or CFM Corporation if the purchase was direct. (Do not operate the stove as this may negate the ability to process the claim with the carrier.)

6. Claims are not valid where the installation does not conform to local building and fire codes or, in their absence, to the recommendations in our Owner's Guide.

7. The salt air environment of coastal areas, or a high-humidity environment, can be corrosive to the porcelain enamel finish. These conditions can cause rusting of the cast iron beneath the porcelain enamel finish, which will cause the porcelain enamel finish to flake off. This warranty does not cover damage caused by a salt air or high-humidity environment.

8. CFM Corporation shall have no obligation to enhance or update any unit once manufactured.

**IN NO EVENT SHALL CFM CORPORATION BE LIABLE FOR INCIDENTAL AND CONSEQUENTIAL DAMAGES. ALL IMPLIED WARRANTIES, INCLUDING THE IMPLIED WARRANTIES OF MERCHANTABILITY AND FITNESS, ARE LIMITED TO THE DURATION OF THIS WRITTEN WARRANTY. THIS WARRANTY SUPERCEDES ALL OTHER ORAL OR WRITTEN WARRANTIES.**

Some states do not allow the exclusion or limitations of incidental and consequential damages or limitations on how long an implied warranty lasts, so the above limitations may not apply to you. This warranty gives you specific rights and you may have other rights which vary from state to state.

### How to Obtain Service

If a defect is noted within the warranty period, the customer should contact a CFM Corporation Authorized Dealer or CFM Corporation if the purchase was direct with the following information:

1. Name, address, and telephone number of the purchaser.
  2. Date of purchase.
  3. Serial number from the label on the back.
  4. Nature of the defect or damage.
  5. Any relevant information or circumstances, e.g., installation, mode of operation when defect was noted.
- A warranty claim will then start in process. CFM Corporation reserves the right to withhold final approval of a warranty claim pending a visual inspection of the defect by authorized representatives.



**CFM Corporation**

---

2695 Meadowvale Blvd. • Mississauga, Ontario, Canada L5N 8A3  
800-668-5323 • [www.cfmcorp.com](http://www.cfmcorp.com)