

OWNER'S MANUAL

With Installation and Operation
Instructions for

STERLING GAS-FIRED ROOM HEATER

FOR STANDING PILOT LIGHT/MILLIVOLT MODELS
MANUFACTURED AFTER SEPTEMBER 1, 1993

Manufactured by

HearthStone®/NHC, Inc.
Stafford Avenue, P.O. Box 1069
Morrisville, Vermont 05661
Telephone 1-802-888-5232

FOR YOUR SAFETY

Do not store or use gasoline or other flammable vapors and liquids in the vicinity of this or any other appliance.

WARNING

Improper installation, adjustment, alteration, service or maintenance can cause personal injury or property damage. For assistance or additional information, refer to details in this manual, consult qualified service personnel or the gas supplier. Your warranty is voided, and NHC, Inc. will accept no responsibility for units that have been modified, tampered with or have been installed or used improperly or contrary to this manual.

FOR YOUR SAFETY - WHAT TO DO IF YOU SMELL GAS

Do not try to light any appliance.
Do not touch any electrical switch; do not use the phone in your building.
Immediately call your gas supplier from a neighbor's phone. Follow the gas supplier's instructions.
If you cannot reach your gas supplier, call the fire department.

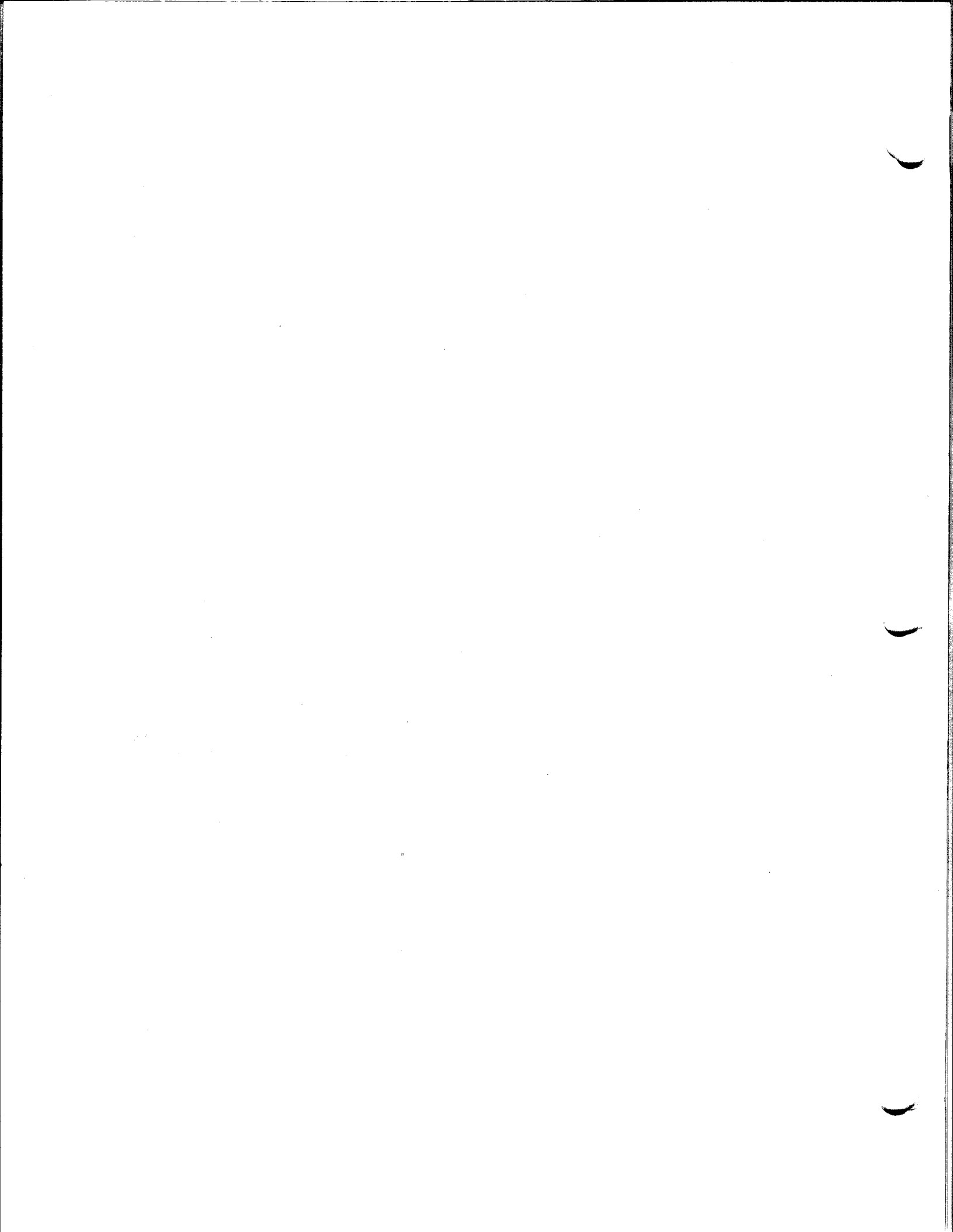

TABLE OF CONTENTS

INTRODUCTION	2
GENERAL OVERVIEW	2
INFORMATION SHEET	3
WARNINGS, CAUTIONS AND SAFETY INFORMATION	4
WHAT TO DO IF YOU SMELL GAS!	5
SPECIFICATIONS	5
UNPACKING AND INSPECTION	6
PACKING LIST	6
UNPACK AND INSPECT FOR DAMAGE	6
INSTALLATION AND CONNECTIONS	7
HEARTH REQUIREMENTS/FLOOR PROTECTION	7
CLEARANCES TO COMBUSTIBLES	7
ELECTRICAL CONNECTIONS	8
VENTING/CHIMNEY REQUIREMENTS	10
GAS SUPPLY	11
LOG PLACEMENT WITHIN UNIT	13
LIGHTING THE UNIT FOR THE FIRST TIME/INITIAL ADJUSTMENTS	15
WARNINGS PRIOR TO FIRST LIGHTING OF UNIT	15
LIGHTING THE UNIT FOR THE FIRST TIME	15
INITIAL ADJUSTMENTS	17
DAILY OPERATION	18
ROUTINE MAINTENANCE AND CARE	19
SERVICING AND TROUBLE SHOOTING	20
OPTIONAL EQUIPMENT	21
HOW TO OBTAIN PARTS AND SERVICE	22
APPENDIX A - ELECTRICAL SCHEMATICS	24
APPENDIX B - SAFETY LABEL	25

INTRODUCTION

GENERAL OVERVIEW

Congratulations on your purchase of a HearthStone® Sterling™ gas-fired vented heater. The Sterling incorporates the latest in energy efficient gas technology which will provide you with clean, efficient heat for years to come. And the combination of natural stones with cast iron (either porcelainized enamel or painted black matte) gives the Sterling a pleasing look which can be maintained with minimum care.

Your Sterling is equipped with a standing pilot light which: 1) generates a millivoltage that powers the wall-mounted thermostat and 2) lights the main burner when the thermostat calls for heat. The standing pilot light/millivolt Sterling requires no external power source for normal operation (unless equipped with the optional blower fan).

Sterling gas heaters can burn either natural gas or liquid propane gas (LP). If the type of gas your Sterling is equipped for does not accommodate your needs, it can be converted to the proper type by qualified service personnel using an optional conversion kit prior to operating the unit.

Standing pilot light/millivolt Sterlings are equipped with a variable output control located on the gas control valve. This feature allows the operator to vary the heat output to suit particular needs. Heat output can be reduced during Fall and Spring when the need for heat is reduced, and increased during Winter months when the need for heat is greatest. Regardless of the heat output setting as controlled by the variable output control, the on/off cycling of the unit is always controlled by the wall-mounted thermostat.

A number of stone choices are available in the Sterling, as well as porcelainized enamel finishes in a variety of colors in addition to painted black matte cast iron. The combination of the stone and cast iron results in a heavy (230 lb) stove with significant thermal mass. As with all HearthStone® stoves, the stone and cast iron absorbs and re-radiates heat produced by the unit. This re-radiation of stored heat is advantageous in that it tends to modulate or smooth out the heat output as the unit cycles on and off in response to the thermostat. And aside from the functional advantages of the thermal mass, the stone and cast iron also looks good, resulting in a stove which is beautiful and unique and well as efficient and practical.

The Sterling will provide years of practical and convenient service. However, as with any gas appliance, the unit must be properly and safely installed and maintained by qualified service personnel to ensure safe and trouble-free operation. Do not attempt to install, service or maintain this unit unless qualified to install, service or maintain gas-fired, vented appliances.

INFORMATION SHEET

Record here all relevant information concerning the purchase and installation of your Sterling gas-fired heater. This information will facilitate servicing, purchase of replacement parts and warranty claims, if necessary. Keep your original receipt in a safe place as proof of purchase.

Serial Number: _____

Fuel type (check one): _____ Natural Gas
 _____ Liquid Propane

Sold by: _____

Phone: _____ Date of Purchase: _____

Installed by: _____

Phone: _____ Date of Installation: _____

Gas Supplier _____

Phone: _____

Read this entire Owner's Manual before installing or operating the Sterling gas fired heater. Retain this manual for future reference.

WARNINGS, CAUTIONS AND SAFETY INFORMATION

NOTE! This gas appliance must be installed and maintained by qualified service personnel. Failure to properly install, adjust and maintain this gas appliance may result in an unsafe or hazardous condition which may lead to carbon monoxide poisoning, fire, explosion, personal injury and loss of life.

CAUTION! This gas appliance must be operated and maintained according to the instructions contained in this owner's manual. The unit must be inspected before use and at least annually by qualified service personnel.

WARNING! Do not use this appliance if any part has been under water. Immediately call qualified service personnel to inspect the appliance and to replace any part of the control system and any gas control which has been under water.

HAZARD! This gas appliance must be connected to a properly installed and maintained venting system (chimney). This appliance is equipped with a down draft sensor switch (vent spill switch). Tampering, modifying, disconnecting or overriding the vent safety shutoff system may result in an unsafe or hazardous condition which may lead to carbon monoxide poisoning and loss of life.

HOT SURFACES! Certain exposed surfaces of the Sterling will reach high temperatures during normal operation. Do not place objects that may obstruct air circulation on, under or near this heater. Clearances to combustibles must be maintained as specified elsewhere in this manual. The Sterling should be located out of traffic and away from furniture, draperies, clothing and flammable material. Clean the area around, under and behind the unit on a regular basis to prevent the accumulation of dust and lint. Children and adults who are unfamiliar with heaters of this type should be alerted to the hazards of high surface temperatures and warned that they should stay away to avoid burns to skin and clothing. Children should be carefully supervised when in the same area as the Sterling heater. Do not leave children unattended in the vicinity of this unit.

FIRE HAZARD! Do not store or use gasoline or other flammable vapors and liquids in the vicinity of this appliance.

ELECTRICAL HAZARD! This appliance is equipped with a three-prong grounded plug if equipped with an optional blower fan. The three-prong grounded plug must be plugged directly into a properly grounded three-prong receptacle. Do not cut or remove the grounding prong from the plug or otherwise attempt to circumvent the grounding protection provided with the unit.

CAUTION! This unit, is equipped with standing pilot light and has a standing pilot light which is lit using a piezoelectric spark generator as described elsewhere in this manual. Never attempt to light the pilot light or main burners by hand with a match or lighter. If, after repeated attempts, the pilot light fails to light, discontinue operation, turn off the gas at the Sterling gas control valve and immediately contact qualified service personnel for assistance.

FUEL WARNING! This unit is designed to burn either natural gas or liquid propane. Never burn paper, wood or any other materials in this unit.

SAFETY INFORMATION! This unit is supplied with decorative ceramic fiber logs and a special rock wool material. If the decorative ceramic fiber become damaged or broken they must be replaced with similar, approved decorative ceramic fiber logs supplied by the manufacturer. Do not replace the manufacturer-supplied decorative ceramic fiber logs or rock wool with unapproved ceramic logs, real wood logs or any other material.

NOTE! The Sterling requires an adequate supply of air to provide ventilation around the unit and to support combustion. Most building have sufficient air infiltration to satisfy these requirements. However, extremely air-tight structures may require the introduction of supplemental air from the outside to allow for the proper operation of the unit.

CAUTION! Any shield, door, safety screen or component removed for servicing the Sterling must be replaced prior to operating the unit. If you believe that your Sterling is not performing properly in any way whatsoever, immediately discontinue operation until the unit has been inspected and approved for continued operation by qualified service personnel.

WHAT TO DO IF YOU SMELL GAS!

- DO NOT ATTEMPT TO LIGHT THIS UNIT OR ANY APPLIANCE! EXTINGUISH ANY OPEN FLAME.
- DO NOT TOUCH ANY ELECTRICAL SWITCH. DO NOT PLUG IN OR UNPLUG ANY APPLIANCE. DO NOT USE ANY PHONE IN YOUR BUILDING.
- OPEN WINDOWS TO VENT THE ROOM AND VACATE THE BUILDING.
- TURN OFF THE MAIN GAS SUPPLY.
- IMMEDIATELY CALL YOUR GAS SUPPLIER FROM A NEIGHBOR'S PHONE. IF YOU CANNOT REACH YOUR GAS SUPPLIER, CALL THE FIRE DEPARTMENT.

SPECIFICATIONS

	<u>Natural Gas</u>	<u>LP</u>
Input rating (0-610m)	41,000 BTU/hour	40,000 BTU/hour
Minimum input rating (0-610m)	20,000 BTU/hour	18,000 BTU/hour
Input rating (610-1370m)	40,000 BTU/hour	38,000 BTU/hour
Orifice size	#31 DMS	#50 DMS
Maximum inlet pressure	10.5 inches W.C. (2.61 kPa)	13.5 inches W.C. (3.36 kPa)
Minimum inlet pressure (for proper manifold adjustment)	4.5 inches W.C. (1.12 kPa)	11.0 inches W.C. (2.74 kPa)
Max. manifold pressure	3.5 inches W.C. (0.87 kPa)	10.0 inches W.C. (2.49 kPa)
Min. manifold pressure	0.9 inches W.C. (0.22 kPa)	2.7 inches W.C. (0.67 kPa)
Nominal efficiency without a fan	72.8%	74.8%
Max. output	31,000 BTU/hour	31,600 BTU/hour
Gas Consumption (standard conditions)	42.6 ft. ³ (3.94 m ³)/hr.	16.1 ft. ³ (1.49 m ³)/hr. 0.44 gal. (1.3 liters)/hr.
Fuel requirements	Natural gas	Liquid propane (LPG)
Fuel supply line size	1/2"	
Flue exit	4" diameter, rear exit	
Chimney requirement	Type B-1 vent, 4" diameter	
Ignition	Standing pilot light	
Certification	Tested to ANSI Z21.11.1b-1990/CAN 1-2.1-M89; *Gas-fired room heaters, vented*	
Installation	Install in accordance with local codes, if any; if not, follow current ANSI Z223.1 (U.S. installations) or current CAN1-B149 installation code (Canadian installations)	
Shipping weight	260 lbs	
Actual weight	230 lbs	
Warranty	1 year limited warranty, excluding door glass, gasket and enamel finish	

Refer to Appendix B - Safety Label for Canadian ratings and orifice sizes for high altitude installations.

UNPACKING AND INSPECTION

PACKING LIST

- 1 - Sterling Gas-fired Heater
- 1 - Boxed Decorative Ceramic Fiber Logs
- 1 - Owner's Manual
- 1 - Warranty Card
- 1 - Bag Rock Wool
- 1 - Thermostat with 20' Thermostat Wire

UNPACK AND INSPECT FOR DAMAGE

The Sterling is packaged by the manufacturer to withstand shipment without damage under most circumstances. However, damage can occur during transit and handling, so take care to inspect for damage when unpacking and installing the unit. If any damage or missing parts are detected, immediately contact your dealer. Do not install or put into service a damaged or incomplete heater.

Prior to removing the shipping carton, inspect the carton for visible signs of damage. Carefully remove the shipping carton. Caution: The three top stones are NOT cemented or otherwise permanently fasten in place! Carefully remove and set aside the three top stones. Use the protective wrapping material to temporarily protect the stones from chipping and damage while the unit is inspected and installed.

Inspect the Sterling for visible or concealed damage. The unit should appear square and true. The stones should be whole and without cracks, chips or breakage. The sheet metal parts should be smooth and free of bends or dents. The enameled cast iron (if porcelainized) should be free of chips or cracks. If visible or concealed damage is found or suspected, contact your dealer for instructions.

With the top stones removed and set aside, undo the three lag bolts which fasten the unit to the pallet. Take care not to mar or chip the enamelled legs on porcelainized units. Lift the stove off the pallet and set it into place. For information regarding hearth requirements and minimum clearances, refer to Hearth Requirements and Clearances to Combustibles elsewhere in this manual.

The decorative ceramic fiber logs supplied with the Sterling are contained within a separate cardboard box within the firebox. Always use great care when handling the decorative ceramic fiber logs as they are fragile and subject to damage or breakage if handled roughly. Open the boxed logs and inspect the logs for breakage. If a broken or damaged log is encountered, contact your dealer for replacement logs. Otherwise, set the logs aside in their box until called for in the installation procedure.

INSTALLATION AND CONNECTIONS

The Sterling is a sophisticated gas-fired appliance. Installation must be completed by qualified service personnel. Any attempt by unqualified personnel to complete venting, gas and electrical connections and other technical components of the installation procedure with which he/she is not familiar and technically qualified may result in an carbon monoxide poisoning, explosion, fire, damage or loss of life. Do not attempt to complete any part of the installation of this unit unless technically qualified to do so.

When installing the Sterling gas heater the following items must be considered for a safe and practical installation:

- Hearth Requirements/Floor Protection
- Clearances to Combustibles
- Electrical Connections (Thermostat)
- Venting/Chimney Requirements
- Gas Supply
- Log Placement Within Unit

HEARTH REQUIREMENTS/FLOOR PROTECTION

The Sterling must be installed on a hard combustible or non-combustible surface. Installation on a stone, ceramic tile or wood floor is acceptable. For installation of the Sterling on carpeting, vinyl tile or other combustible material other than wood flooring, the unit shall be installed on a metal, wood panel or other non-combustible hearth. The hearth must extend the full width and depth of the Sterling with a minimum hearth dimension of 17" x 27" (432 X 686 mm).

CLEARANCES TO COMBUSTIBLES

Due to high surface temperatures, the Sterling should be located out of traffic and away from furniture and draperies. Clothing and other flammable material should not be placed on or near the Sterling heater.

Always maintain adequate clearances around the air openings into the combustion chamber and allow for adequate ventilation. When positioning the unit be sure to consider the need for access to the gas control valve access door on the lower right side of the unit as well as full access for periodic cleaning and servicing.

Minimum clearances to combustibles must be maintained as shown in Figures 1-5. Note that the rear clearance to combustibles will be determined by either the unit's or vent pipe's minimum clearance, depending on whether the installation calls for a top exit (vertical) vent within the room (Figures 1 & 2) or a rear exit (horizontal), through-the-wall vent (Figure 4).

For vertical installations, the distance from a single wall stovepipe to the wall is 6" (152 mm) and from a type B-1 vent to the wall is 1" (25 mm) (Figure 1). For horizontal installations, the stove must be 5" (127 mm) from the wall (Figure 4). When using the Reduced Clearance Top Exit Adaptor, if using a single wall stovepipe, the stovepipe must be 6" (152 mm) from the wall, and if using a Type B-1 Vent, the top edge of the adaptor heat shield must be 3" (76 mm) from the wall (Figure 2). (In any case, the adaptor must **not** be less than 3" (76 mm) from the wall.)

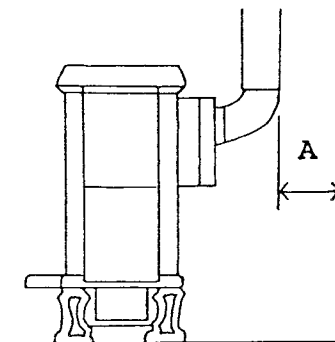

SINGLE WALL: A=6"
TYPE B-1 VENT: A=1"

Figure 1 - Stovepipe Clearances to Combustibles, Vertical Installation

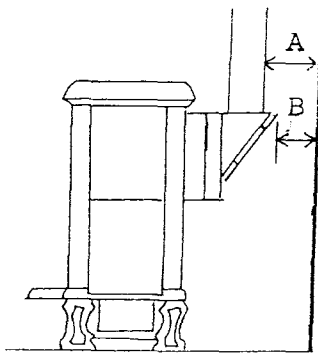

SINGLE WALL STOVEPIPE: $A=6''$
 TYPE B-1 VENT: $B=3''$

Figure 2 - Rear Clearances to Combustibles,
 Vertical Installation/Reduced Clearance

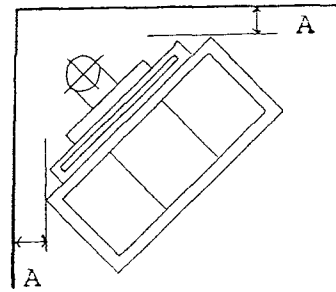

$A=5''$

Figure 3 - Corner Clearances to Combustibles

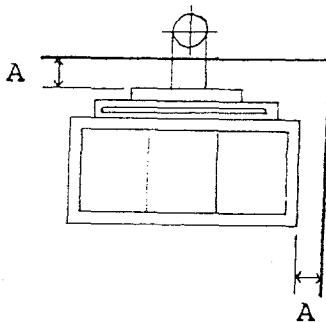

$A=5''$

Figure 4 - Rear Clearances to Combustibles,
 Horizontal Installation; Side Clearances to
 Combustibles (Applicable to all types of
 installations)

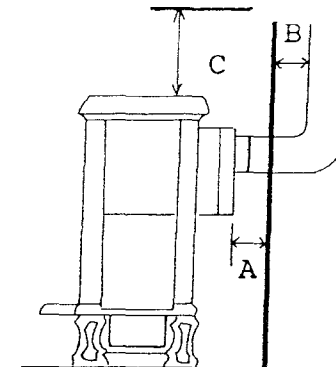

$A=5''$
 SINGLE WALL STOVEPIPE: $B=6''$
 TYPE B-1 VENT: $B=1''$
 $C=14''$

Figure 5 - Rear Clearance to Combustibles,
 Horizontal Through-the-Wall Installation

ELECTRICAL CONNECTIONS

Thermostat

The Sterling requires a wall-mounted thermostat for operation. The thermostat controls the unit by "calling for heat" and turning the unit on when the room is cold, and turning the unit off once the room has warmed sufficiently to satisfy the thermostat.

The Sterling thermostat is controlled by a 750 millivolt DC two-wire circuit. Both the thermostat and 20 feet of 18 gauge thermostat wire are included with the Sterling as standard equipment.

Thermostat Placement

The thermostat should be placed in the same room or living space as the Sterling, typically 5' (1.5 m) off the floor and away from areas of draft, direct sunlight or other influences which would cause the temperature in the vicinity of the thermostat to be unrepresentative of the room temperature in general. Such influences might include strong lighting, a heater vent from the central heating system, a nearby drafty window, etc.

Placement of the thermostat on an inside wall rather than an outside wall is generally preferable. Do not place the thermostat directly behind or too near the Sterling, otherwise every time the thermostat calls for heat and the unit turns on, heat from the unit will immediately satisfy the thermostat and turn the unit off.

Thermostat Wiring

The thermostat should be connected to the Sterling using no more than 20' (6 m) of the 18 gauge insulated thermostat wire supplied. The thermostat wire from the Sterling to the thermostat can be surface mounted or routed under the floor, through walls, etc. If the 20' (6 m) of wire supplied with the Sterling is not long enough, 16 gauge wire may be used but must not exceed 40' (12 m) in length. In either case, be sure to leave a small coil of wire behind the Sterling so that the unit can be moved out of position for servicing and cleaning.

Connect the two conductor thermostat wire to the two white wires found near the gas control valve. One wire is attached to the gas control valve, and the other is attached to the spill switch (underneath the rear flue exit). When making these connections, position the thermostat wire so that it extends towards the wall behind the Sterling, then towards the thermostat. You will need two crimp connectors to connect the two white wires on the Sterling to the two thermostat wires. Strip away 1/4" (6 mm) of insulation from each of the two thermostat wires. Insert the wires into the two crimp connectors, and crimp each end of the connector twice, once so as to crimp against the stripped wire and once so as to crimp against the insulated portion of the wire. Check to ensure that the connections are secure and permanent.

At the thermostat, the thermostat wire should be connected to the two connection screws on the thermostat base plate per the instructions received with the thermostat. Take care not to over-tighten the connection screws and not to damage the internal parts of the thermostat. The thermostat should be mounted level for proper operation and accurate temperature control.

VENTING/CHIMNEY REQUIREMENTS

Normally Aspirated Chimneys

The Sterling is a high efficiency gas heater. With operating efficiencies as high as 76%, most heat output is retained within the living space, with minimal heat leaving the room via the chimney. However, some heat is required in all chimneys in order to establish and maintain a draft. Since most of the heat is retained in the living space with minimal heat entering the chimney, it is imperative that the chimney/venting system be properly sized and installed in order to establish and maintain the draft required for the unit to function.

The Sterling must be properly connected to a 4" (102 mm) diameter type B-1 vent which is constructed and installed in accordance with NFPA54 and NFPA211. Single wall vent pipe may be used within the same room as the Sterling so long as adequate (6" or 152 mm) clearance is maintained from the single wall pipe to combustible surfaces. The single wall vent pipe must connect to double-wall type B-1 vent at the first wall or ceiling penetration, and continue with type B-1 vent from thereon. The minimum clearance from type B-1 vent to combustibles is 1" (25 mm).

Connect the single wall vent pipe or the B-1 vent to the flue collar located on the rear surface of the unit using 3 sheet metal screws. For wall, roof or partition penetration, refer to the current edition of ANSI Z223.1 or CAN1-B149 for instructions and clearances to combustibles. The Sterling can be connected to an existing, properly constructed masonry or prefabricated chimney so long as the type B-1 vent is extended through the entire length of the chimney. An annual inspection is required to confirm that the vent is unobstructed. The Sterling must not be connected to or combined with a chimney flue serving other gas or solid fuel appliances.

Type B-1 vent pipe is intended primarily for installation inside buildings to provide an essentially vertical passageway for flue gases from the vented gas appliance to the outside air. When it is impractical to install B-1 vent pipe inside a building, it may be installed outdoors provided that it is: 1) certified for outside installation, 2) installed in accordance with the manufacturer's installation instructions and 3) adequately chased (enclosed) and insulated (per Venting Tables, Category I - Central Furnaces, AGA and GAMA. July 1991; Standards for Gas Vents, National Standards of Canada; and CAN/CGA-B149.1-M91). Exterior B-1 venting not chased and insulated below the roof line may experience continuous condensation depending on the locality. B-1 vent pipe passing through an unused masonry chimney flue is not considered to be exposed to the outdoors.

Four inch flexible pipe can be used in place of Type B-1 vent pipe wherever it is impractical or impossible to install rigid Type B-1 vent pipe. However, flexible pipe is less desirable than B-1 vent pipe, because there is a greater heat loss along the length of flex pipe which may result in a reduced or unacceptable draft.

Draft Hood/Down Draft Sensor/Spill Switch

The Sterling has a draft hood as part of its rear assembly. The draft hood must not be altered or obstructed. The Sterling must be installed so that the draft hood is in the same atmospheric pressure zone as the combustible air inlet for the unit. The Sterling cannot and must not be connected to an outside air source; the unit must take its combustion air from the living space in which it is installed.

The draft hood is equipped with a safety shutoff down draft sensor switch (spill switch) which is located in the draft hood just beneath the flue collar on the rear of the unit. This switch is designed to sense a loss of draft within the chimney. The down draft sensor switch is wired in series with the thermostat and is typically in the closed position. In order for the unit to operate, both the down draft sensor switch and the thermostat must be in the closed position.

Should the Sterling fail to establish or lose its draft while in operation, hot exhaust gasses will spill into the room through the bottom of the draft hood instead of exiting the draft hood via the flue collar and venting to the outdoors. When this undesirable down draft condition occurs the hot gasses

spilling out of the draft hood will heat the spill switch causing it to open which turns the unit off.

Do not modify, disconnect or otherwise defeat the purpose of the down draft sensor switch. Should the down draft sensor repeatedly (ON-OFF-ON in approximately 10 minute intervals) open thereby shutting down the unit, it is indicative of an unsafe venting condition which must be corrected. Operation of this unit when not properly connected to a properly installed and maintained venting system or tampering with the vent safety shutoff system can result in carbon monoxide (CO) poisoning and possible death.

Power Venting

For applications where it is impractical or impossible to extend B-1 vent pipe to above the existing roof line, the Sterling can be vented using a power vent. A power vent is essentially a specialized electric fan mounted on the outer wall of the building which is connected to the heater via flue pipe. When the thermostat calls for heat, the power vent turns on and creates a draft in the flue pipe similar to the draft created by a properly functioning conventional chimney. The Sterling then operates in a normal fashion, satisfied by the simulated draft. A series of interlocking safety devices prevents operation of the heater unless the power vent is operating properly. Both the Sterling and the power vent are controlled by the wall thermostat and neither will operate if there is a power failure. For installations requiring power venting, contact the manufacturer for a list of certified power vent suppliers. The power vent supplier will in turn supply the power vent installation instructions.

GAS SUPPLY

Factory-Ready for Gas Operation

All Sterlings are shipped from the manufacturer fully assembled and ready for natural gas or LP (liquid propane) gas operation with minor adjustment. However, if the Sterling needs to be converted from natural gas to LP or from LP to natural gas, conversion of the unit must be performed by qualified service personnel using the manufacturer-supplied optional conversion kit. Follow the conversion instructions supplied with the conversion kit.

Gas Connection

The gas supply line connection is made to the Sterling's gas control valve just inside the right rear leg of the unit using a 3/8" male NPT fitting. The supply line should be 1/2" diameter or appropriately sized to provide a sufficient gas supply to meet the maximum demand of the unit without undue loss of pressure.

The unit must be installed and connected in accordance with local codes, or in absence of local codes, with the most current edition of the National Fuel Gas Code ANSI Z223.1/NFPA 54 or CAN1-B149. The supply line must include a manual shut-off valve and union so that the unit can be disconnected for servicing. Provide a 1/8" NPT plugged tap, accessible for test gauge connection, immediately upstream of the gas supply connection to the unit.

Gas Pressure Adjustment

Once connected to the gas supply, the supply line and manifold gas pressures must be tested to ensure that they meet the minimum gas supply pressures as listed in the Specifications for the type of fuel in use (natural gas or LP) for the purpose of input adjustment. The supply line pressure is tested by connecting a manometer to the supply line and adjusting the incoming pressure if necessary to meet the required supply line pressure as listed in the Specifications. The manifold pressure is tested by connecting the manometer to the manifold pressure tap on the gas control valve (Figure 7).

This appliance and its individual shutoff valve must be disconnected from the gas supply piping system during any pressure testing of that system at test pressures in excess of 1/2 psig. The Sterling must be isolated from the gas supply piping system by closing its individual manual shutoff

valve during any pressure testing of the gas supply piping system at test pressures equal to or less than 1/2 psig.

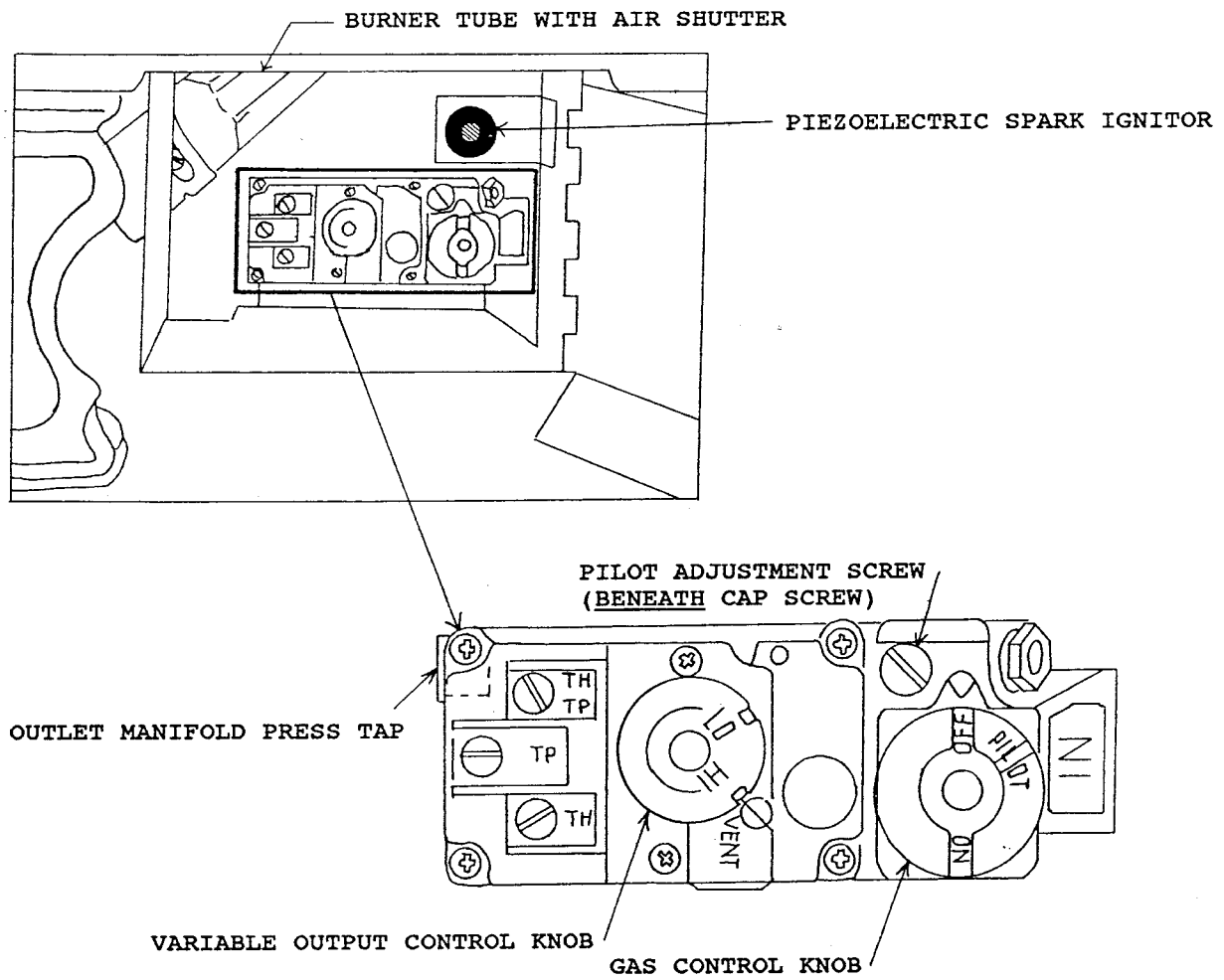

Figure 7 - Gas Control Valve

LOG PLACEMENT WITHIN UNIT

Before placing the log set on the burner tube, be sure the screen supplied with the stove is placed on the burner tube. It is bent to a 90° angle. One side of the screen slides between the front of the stove and the burner tube. The other side rests on the burner tube. The side with the slots cut out is on top of the burner tube (Figure 8).

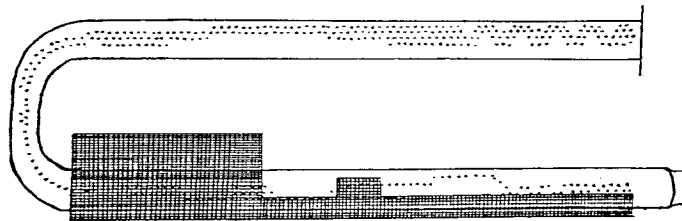

Figure 8 - Screen Placement on Burner Tube

The log set must be placed in the firebox at its precise location. There are four white tabs attached to the log set to aid in correct placement. All tabs are located on the under side of the log set. Two are on the far right, one at the far left, and one is in the middle and towards the front of the log set. Figure 9 shows a top view of the burner tube and the precise location and identification of each tab.

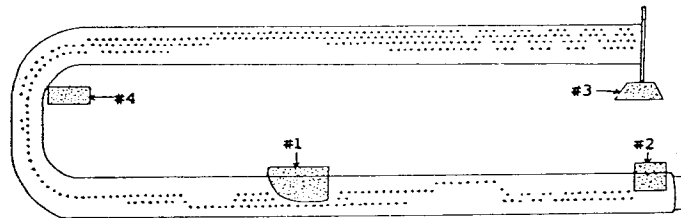

Figure 9 - Tab Locations on Burner Tube

Since the two tabs located towards the rear of the log set are difficult to see, it is easiest to correctly align the log set by noting the correct positioning of Tabs #1 and #2, the two front tabs.

The exact placement of Tab #1, the middle, front tab, is critical as it sits on the burner tube in an area without holes. The holes surrounding the tab will be within 1/8" (3 mm) of the tab. Figures 9 & 10 will aid in determining Tab #1's location. Do not cover any holes with the tab, and don't set the tab more than 1/8" (3 mm) away from the holes to the right of the tab.

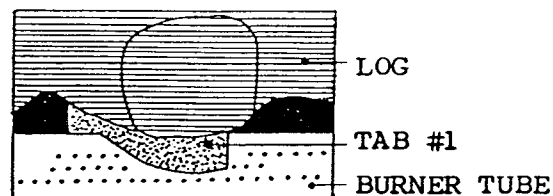

Figure 10 - Tab #1 Location

The front edge of Tab #2, the right, front tab, lines up with the second row (counting from the front to the back of the stove) of holes in the burner tube. It sets on the tube at the right end where the holes cease. Figures 9 & 11 will aid in determining the location of Tab #2.

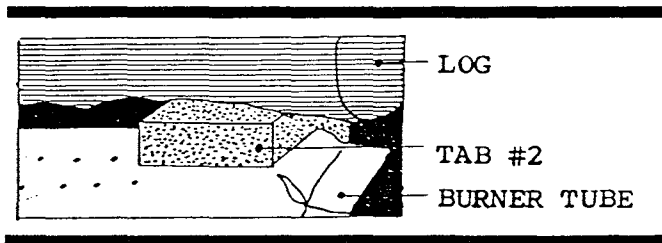

Figure 11 - Tab #2 Location

Tab #3, the right rear tab, is strategically located to keep the log set from moving too far back onto the rear of the burner tube. This tab ultimately rests against the side of flange on the burner tube as seen in Figure 12. Tab #4, the far left tab, serves to prevent the log set from moving too far to the left.

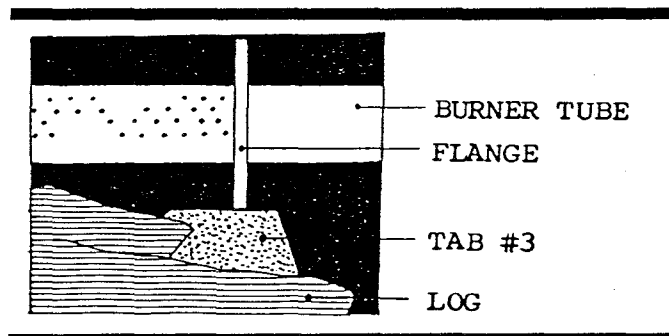

Figure 12 - Top View, Tab #3 Location

Only the decorative ceramic fiber log set supplied with the unit should be placed in the firebox. Do not place other ceramic logs, real wood logs or other material in the firebox. If the log set is damaged or broken contact your dealer or the manufacturer for a replacement.

If the log set does not set into the firebox exactly as outlined above, contact our customer service department for assistance. Exact positioning of the log set is required in order to obtain a pleasing flame pattern and efficient combustion. Incorrect log placement may cause carbon build-up, excess thermal stress on the log set and stove parts, reduced efficiency, and high levels of carbon monoxide.

Once the log set is in position, the rock wool can be placed. The rock wool which gives the fire a look of burning embers is shipped in a small plastic bag. The material is brown and fluffy. Little pieces need to be picked with tweezers and placed on the screen in front of the logs. The pieces should be as small as possible without allowing them to fall through the screen; they should be scattered over the entire screen and should touch each other as little as possible. Your patience in this exercise will be greatly rewarded.

The decorative ceramic fiber log set which will give long service when in use; however, they will break if subjected to rough or improper handling. Broken or cracked logs should be replaced. When removing and replacing the log set from the unit during routine cleaning or servicing of the unit, take care not to damage the logs and to position the log set per the instructions above. Also, take care not to chip the enamel on the door and door frame when removing and replacing the log set (if a porcelainized unit).

LIGHTING THE UNIT FOR THE FIRST TIME/INITIAL ADJUSTMENTS

Once the Sterling has been set in place and connected as described above, the unit is ready to be lit for the first time. Each Sterling is tested prior to shipment by the manufacturer, so ignition should take place without failure. However, a number of small adjustments may be necessary to compensate for variations in gas pressure, altitude and other factors particular to each installation. Lighting the Sterling for the first time and adjustments to the unit should be performed by qualified service personnel.

WARNINGS PRIOR TO FIRST LIGHTING OF UNIT

Smoke and Fumes Warning

When lit for the first time the Sterling will emit some smoke and fumes. This is normal "off-gassing" of the paints and oils used in the assembly and manufacturing of the unit. Open windows to vent the room as necessary. The off-gassing and fumes will subside after the first 10 to 20 minutes of operation.

Break-In Warning

The natural stones used in the assembly of the Sterling were polished using a water-based polishing system prior to assembly of the unit. Any residual moisture in the stones must be dried out slowly to avoid damaging the stones. This is accomplished by adhering to the following break-in procedure.

When lit the first three times, the Sterling should be burned for no more than 10 minutes, then allowed to cool for 1 to 2 hours. This gentle warming and cooling of the unit will allow any residual moisture in the stones to evaporate slowly. Once this break-in procedure has been completed, the Sterling can be burned at will with no time restrictions on the length of burn.

Pilot Light Warning

The Sterling has a piezoelectric spark ignitor (the red push button located just above the gas control valve behind the gas control valve access door) which ignites the pilot light by means of a spark at the pilot light assembly. Do not attempt to light the unit with a match or by any means other than the piezoelectric spark.

LIGHTING THE UNIT FOR THE FIRST TIME



Before lighting the unit for the first time check all around the unit for the smell of gas. Be sure to smell down by the floor as some gasses are heavier than air and will settle on the floor. If you smell gas immediately follow the What To Do If You Smell Gas warning.

WHAT TO DO IF YOU SMELL GAS!

- DO NOT ATTEMPT TO LIGHT THIS UNIT OR ANY APPLIANCE! EXTINGUISH ANY OPEN FLAME.
- DO NOT TOUCH ANY ELECTRICAL SWITCH. DO NOT PLUG IN OR UNPLUG ANY APPLIANCE. DO NOT USE ANY PHONE IN YOUR BUILDING.
- OPEN WINDOWS TO VENT THE ROOM AND VACATE THE BUILDING.
- TURN OFF THE MAIN GAS SUPPLY.
- IMMEDIATELY CALL YOUR GAS SUPPLIER FROM A NEIGHBOR'S PHONE. IF YOU CANNOT REACH YOUR GAS SUPPLIER, CALL THE FIRE DEPARTMENT.

As an additional safety precaution prior to lighting the unit for the first time, wait 5 minutes to allow

any residual gas within the unit to dissipate. If you do not smell gas after this five minute period, proceed with the lighting procedure. If you do smell gas, do not proceed with the lighting procedure. Instead, immediately refer to the What To Do If You Smell Gas warning.

Prepare for the lighting procedure by adjusting the thermostat to its lowest setting or OFF position, if so equipped. Open the gas control valve access door at the lower right side of the unit and locate the gas control knob (Figure 7). If the gas control knob is not in the OFF position, turn the knob fully clockwise  to OFF. Locate the variable output control (Figure 7) and turn it fully clockwise  to the highest setting.

Now light the unit for the first time according to the following instructions:



WARNING: If you do not follow these instructions exactly, a fire or explosion may result causing property damage, personal injury or loss of life.

- A. This appliance has a pilot which must be lighted by hand. When lighting the pilot, follow these instructions exactly.
- B. BEFORE LIGHTING, smell all around the appliance area for gas. Be sure to smell next to the floor because some gases are heavier than air and will settle on the floor.

WHAT TO DO IF YOU SMELL GAS

- DO NOT ATTEMPT TO LIGHT THIS UNIT OR ANY APPLIANCE! EXTINGUISH ANY OPEN FLAME.
 - DO NOT TOUCH ANY ELECTRICAL SWITCH. DO NOT PLUG IN OR UNPLUG ANY APPLIANCE. DO NOT USE ANY PHONE IN YOUR BUILDING.
 - OPEN WINDOWS TO VENT THE ROOM AND VACATE THE BUILDING.
 - TURN OFF THE MAIN GAS SUPPLY.
 - IMMEDIATELY CALL YOUR GAS SUPPLIER FROM A NEIGHBOR'S PHONE. IF YOU CANNOT REACH YOUR GAS SUPPLIER, CALL THE FIRE DEPARTMENT.
- C. Use only your hand to turn the gas control knob. Never use tools. If the knob will not push in or turn by hand, don't try to repair it; call a qualified service technician. Any force or attempt to repair may result in fire or explosion.
 - D. Do not use this appliance if any part has been under water. Immediately call a qualified service technician to inspect the appliance and to replace any part of the control system and any gas control which has been under water.

LIGHTING INSTRUCTIONS (per lighting instructions as printed on inside of gas control valve access door):

1. STOP! Read the safety information above.
2. Set the thermostat to lowest setting.
3. Unplug the fan accessory, if so equipped.
4. Push in and turn gas control knob clockwise  to "OFF".
5. Wait (5) five minutes to clear out any gas. If you then smell gas, STOP! Follow "B" in the safety information above. If you do not smell gas, go to the next step.
6. Turn knob on gas control counterclockwise  to "PILOT".
7. Push in control knob all the way and hold in. Immediately light the pilot with the gas lighter [push in and "click" the red piezoelectric spark ignitor button]. Continue to hold the control knob in for about one (1) minute after the pilot is lit. Release knob and it will pop back out. Pilot should remain lit. If the pilot goes out, repeat the operation.

- If knob does not pop out when released, stop and immediately call your service technician or gas supplier.
 - If the pilot will not stay lit after several tries, turn the gas control knob "OFF" and call your service technician or gas supplier.
8. Turn gas control knob counterclockwise  to "ON".
 9. Shut the gas control valve access door.
 10. Plug in fan accessory, if so equipped.
 11. Set thermostat to desired setting.

TO TURN OFF GAS TO APPLIANCE

1. Set thermostat to lowest setting.
2. Turn off all electric power to the appliance if service is to be performed.
3. Turn gas control knob fully clockwise  to "OFF". Do not force.
4. Shut gas valve access door.

As a supplement to the above instructions: When pressing/clicking the red piezoelectric spark ignition button (Figure 7) to light the pilot light, watch through the glass front door of the unit. Click the red ignitor button until a flame is visible at the pilot light and once lit, continue to press on the gas control knob for another 20 seconds, then release. Ascertain that the pilot light is still lit by looking through the front door. If lit, then turn the gas control knob fully counterclockwise  to the ON position. If the pilot light failed to light or if it went out due to a premature release of the gas control knob while pressed in the PILOT position, then repeat the lighting process as described above.

Once the pilot light has been lit, the main burner is lit moving the thermostat to a high setting so that it "calls" for heat (i.e. turns the unit on). The main burners should light immediately. Note that the on/off cycling of the main burner is controlled by the thermostat but that the pilot light remains lit regardless of the thermostat setting. To turn the pilot light off, turn the gas control valve fully clockwise  to the OFF position.

Once the unit is lit, observe the flame pattern and adjust as necessary per the following instructions while keeping in mind the off-gassing and break-in warnings listed above.

INITIAL ADJUSTMENTS

Variable Output Control

The gas control valve is equipped with a variable output control (Figure 7). This control varies the rate of heat produced by the unit by varying the gas pressure to the main burner tube. The length of the burn cycle, however, is always controlled by the thermostat. Using the variable output control, the heat output of the unit can be reduced for mild Fall and Spring months or maximized for the colder Winter months. This adjustment can be made by the homeowner as necessary by turning the variable output control knob to HI or LO or any setting in between.

Air Shutter Adjustment

There is an adjustable air shutter located on the main burner tube to the left of the gas control valve behind the hinged gas control valve access door (Figure 7). The air shutter is used to regulate the air-to-gas combustion mixture which in turn influences the size and color of the flames. The air shutter is preset by the manufacturer for optimum operation. However, it may need adjustment once the unit has been installed to compensate for variations in supply line pressure, altitude and other variables.

To determine if the air shutter needs adjustment, it is necessary to view the flame pattern with the variable output control knob at its highest setting. Allow the unit to operate for 10 minutes to allow the

behind the logs, the air shutter may be closed too far; 3) No flames should extend more than 2" above the logs.

To adjust the air shutter opening, simply loosen the screw on the shutter (Figure 13) and turn the shutter either clockwise ↻ to close the air opening or counter-clockwise ↻ to open the air opening. Closing the air shutter allows less oxygen to burn and results in a higher, yellow flame. Opening the shutter allows more oxygen to burn and results in a lower, blue flame. Adjustment may be done while viewing the fire. Once the desired flame pattern is achieved, tighten the screw.

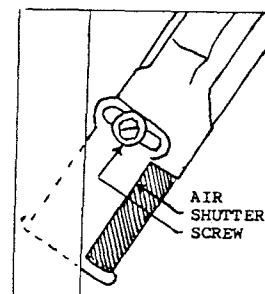

Figure 13 - Air Shutter

If the flame pattern continues to indicate a low flame or over-fire condition regardless of air shutter setting then it is likely that the gas supply pressure to the unit is too low or too great. Such a condition cannot be corrected through air shutter adjustment; an adjustment must be made to the gas supply pressure. Supply line and manifold gas pressure adjustments must be performed by qualified service personnel. Do not attempt to complete any part of the installation or adjustment of this unit unless technically qualified to do so.

When adjusting the air shutter for flame color take care not to obtain a flame which is too yellow (shutters closed; too little oxygen). While such a flame may be aesthetically pleasing, it is the result of incomplete combustion which will eventually result in an accumulation of carbon in the firebox, on the logs, burner tubes and window glass.

Pilot Adjustment

The pilot light flame should be large enough to engulf the sensor/thermocouple located just next to the pilot light, but not so large as to create excessive noise or consume excessive gas. The pilot light is preset by the manufacturer and should not need adjustment. However, it can be adjusted by means of the pilot light adjustment screw located on the gas control valve (Figure 7). Note that the actual adjustment screw is located beneath the cap screw labeled "pilot adjustment screw" on the gas valve. Be sure to replace the cap screw on the gas control valve once adjustments to the pilot light setting have been completed.

A critical component of the pilot light assembly is the pilot hood which serves to direct the flame of the pilot light toward the sensor/thermocouple and toward the main burner tube. A bent, dirty or otherwise defective pilot hood can result in difficult or non-ignition of the unit. Note too that the pilot light flame must properly engulf the thermopile so that the thermopile can generate sufficient millivoltage (750mv) to power the wall thermostat. Control of the Sterling by the wall-mounted thermostat may become erratic or non-existent if the pilot light flame is too small or misdirected away from the thermopile.

DAILY OPERATION

The Sterling gas-fired heater is easily operated by the homeowner once installed and adjusted by qualified service personnel. The unit is always controlled via the wall-mounted thermostat. Set the thermostat to the desired room temperature and the unit will cycle on and off as required. By adjusting the variable output control located on the gas control valve, the rate of heat output can be varied to meet the heating requirements of the season. Choosing a low flame setting will result in longer burn cycles at a reduced output, while choosing a high flame setting will result in a shorter, hotter burn cycle. Through trial and error the homeowner can select the optimum flame size for their setting and application.

When the unit first lights, especially when cool, it is normal to experience some condensation on the inside of the window glass. This condensation will burn off within the first few minutes of operation. If

longer burn cycles at a reduced output, while choosing a high flame setting will result in a shorter, hotter burn cycle. Through trial and error the homeowner can select the optimum flame size for their setting and application.

When the unit first lights, especially when cool, it is normal to experience some condensation on the inside of the window glass. This condensation will burn off within the first few minutes of operation. If continuous condensation on the window glass or dripping water from any part of the unit or venting system (chimney) is noted, immediately discontinue operation of the unit and contact qualified service personnel.

Although not required, the unit can be taken out of service if it is not to be used for a period of time, such as through the Summer months. To take the unit out of service, set the thermostat to the lowest setting or OFF position, and turn the gas control knob fully clockwise to the OFF position. When putting the unit back into service follow the lighting instructions described elsewhere in this manual.

Keep the area around the Sterling clear of combustible materials, gasoline and other flammable vapors and liquids. Do not allow the placement of items near the unit that will obstruct air flow or be ignited due to the heat from the surfaces of the stove.

ROUTINE MAINTENANCE AND CARE

The Sterling requires minimal routine maintenance and care. The unit should always be cool and off when being cleaned or maintained.

The unit should receive regular cleaning on, under and around the stove to prevent the build up of dust and lint. The exterior surfaces of the unit can be cleaned using soap and water and a soft cloth. Do not use abrasive or chemical cleaners and take care not to scratch the stones, glass or enamel finish (if so equipped) when cleaning the unit. The use of chemical or wax-based cleansers or polishes is not recommended due to the potential for discoloration of the stones when the residue of the cleansers or polishes is exposed to heat.

The firebox should receive periodic cleaning to prevent the accumulation of dust, lint and other debris. To clean the fire box, lower the thermostat to the lowest setting or OFF position (if so equipped), and turn off the gas at the gas control valve. When the unit is cool, unfasten the front door and carefully remove the decorative ceramic fiber log set taking care not to damage the logs or chip the enamel cast iron (if porcelainized). Clean the entire firebox, the burner tube and carefully vacuum the entire surface of the log set. Take care to thoroughly vacuum the ports (holes) along the top of the burner tube.

With the decorative ceramic fiber logs out of the firebox, fasten the door shut and momentarily light the unit according to the lighting instructions described elsewhere in this manual. Check to ensure that a flame is burning from each burner port and that all flames are approximately the same in height and intensity. The pilot light flame should be large enough to engulf the sensor/thermocouple as described elsewhere in this manual (Initial Adjustments: Pilot Adjustment). Turn the unit off by lowering the thermostat, turning off the gas at the gas control valve. Allow the unit to cool.

Check and clean any burner ports which are not burning or burning properly. Clean burner ports using a soft brush or vacuum cleaner. If the pilot light flame height needs adjustment it should be adjusted by qualified service personnel as described elsewhere in this manual.

Complete the cleaning procedure by carefully replacing the log set within the firebox as described elsewhere in this manual. Close and fasten the front door. Turn on the gas, light the unit and check for proper operation.

Regularly check that the area around the Sterling is kept free and clear from combustible materials, gasoline and other flammable vapors and liquids. Check that the flow of combustion and ventilation air is not obstructed.

Once a year the unit and venting system should be inspected by qualified service personnel to ensure that they are clean, free of obstruction, safe and in good working order. If service or maintenance is required it should be performed by qualified service personnel.

SERVICING AND TROUBLE SHOOTING

The Sterling gas heater should be serviced by qualified service personnel. Do not attempt to service any part of this unit unless qualified to do so. When servicing the unit follow the procedures described in this manual, as appropriate. Use factory-approved and generally accepted practices when servicing this appliance. Do not put into service a unit which is malfunctioning or not performing according to specifications.

The Sterling will provide trouble-free operation under most circumstances. Should the unit perform in an abnormal manner or fail to operate, immediately discontinue operation and contact qualified service personnel for servicing. Do not attempt to service or adjust this unit unless qualified to do so.

Main burner refuses to light.

Check that the gas is on, both at the gas control valve on the unit and at any manual shut off valves on the gas supply line leading to the unit.

Check that the pilot light is lit by visually confirming the presence of a flame at the pilot light assembly, looking through the front door glass, under the logs, towards the right side of the unit.

Check that the pilot light assembly is clean and free of carbon buildup. Check that the pilot light flame properly engulfs the sensor/thermocouple.

Check that the thermostat is set to a high setting (closed circuit). If there is a doubt whether the thermostat is operating properly, isolate the thermostat from the circuit by disconnecting the wires at the thermostat and connecting the wires to one another. If the unit lights with the wires crossed at the thermostat, then the malfunction is probably in the thermostat itself. Replace the thermostat.

No pilot light; pilot light goes out during operation.

Pilot orifice may be plugged. Check and clean orifice. The pilot will not remain lit if the thermopile is defective. Replace thermopile. The pilot light may be blown out if the unit is in a very drafty location. After a few minutes, the unit will stop functioning if the pilot light goes out. The solution is to cure the source of the draft or to reposition the unit out of the draft.

Unit burns for a few minutes, then shuts off, then cycles on and off every few minutes.

Repeated, frequent cycling of the unit every few minutes is typically due to one of two causes:

- 1) The unit is satisfying the thermostat too soon, that is, the thermostat is simply reacting to the heat output and turning the unit off. Consider thermostat placement. If the thermostat is too close to the unit, it will be satisfied by the heat output of the unit and turn the unit off before the room itself has been heated. Review the section on thermostat placement described elsewhere in this manual and relocate thermostat.

If thermostat placement is correct but a longer, milder burn is desired, lower the rate of heat output. This is accomplished by adjusting the variable output control knob located on the gas control valve as described elsewhere in this manual. Heat output is lowered, the unit will take longer to heat the space and the burn cycle will be longer.

- 2) The Sterling is equipped with a down draft sensor switch also known as a "spill switch" located in the draft hood just beneath the flue collar on the rear of the unit. This switch, which is normally closed, is wired in series with the thermostat, both of which must be in the closed position for the unit to operate.

The down draft sensor is designed to turn the Sterling off should the unit fail to establish or lose its draft while in operation. When an undesirable down draft condition occurs, hot gasses spill into the room, heating the spill switch which causes the switch to open which turns the unit off. The unit will restart once the switch cools down.

A down draft situation can cause the unit to cycle on and off every few minutes, seemingly for no apparent reason. If a down draft situation is suspected, it can be confirmed by *temporarily* crossing the down draft sensor switch with a jumper wire, thereby isolating it from the circuit. If a cycling unit now runs continuously with the down draft sensor switch isolated from the circuit, this confirms the down draft situation. The solution is to modify or improve the venting system to eliminate the down draft situation. Remove the temporary jumper from the down draft sensor switch. Do not attempt to permanently alter, eliminate or thwart the down draft sensor switch. Any such attempt can lead to carbon monoxide poisoning and loss of life.

Carbon buildup on logs, burners, window glass and/or pilot light assembly.

An accumulation of carbon anywhere within the firebox is indicative of incomplete burning of the gas due to a lack of combustion oxygen or too much fuel for normal levels of oxygen. Carbon build-up can often be predicted by a flame which is too yellow. The cure is to first carefully clean the carbon buildup from the effected areas within the firebox, then to adjust the air shutter on the main burner tube as described elsewhere in the manual. If this doesn't correct the problem, have a qualified service person check the gas pressure.

Flame is too big, hitting the top of the firebox. Unit is overheating.

A flame which is too big can be caused by supply line or manifold gas pressure which is too high or an improper air shutter setting on the main burner tube. Review the sections on gas pressure adjustment and air shutter settings elsewhere in this manual for proper adjustment.

OPTIONAL EQUIPMENT

Blower fan.

An optional blower fan is available from the dealer or manufacturer to boost heat output and improve air circulation within the room. The blower fan, which is powered by standard 110/115 volt, 60 cycle, 1.0 amp household current, is easily attached to the lower rear casting of the unit. The blower fan has a thermocouple which is fastened to the draft hood on the rear of the unit. When the draft hood heats up, the blower fan turns on. When the draft hood cools off, the blower fan turns off. The blower fan will continue to operate for a period of time after the unit shuts off as it takes some time for the stove to cool down.

Reduced Clearance Top Exit Adaptor.

An optional reduced clearance top exit adaptor is available to reduce clearances to combustibles behind the stove on vertical installations (See Figure 1 vs. Figure 2). The reduced clearance top exit adaptor is typically used in settings where the vent (stovepipe) is to run from the flue collar on the rear of the stove up to and through the ceiling above the stove (as opposed, for example, to through the wall immediately behind the stove and up the outside wall of the building), and where it is necessary to have the stove as close as possible to the wall (while still maintaining required minimum clearances). The reduced clearance top

exit adaptor allows the stove to be set closer to the wall by eliminating the 90° elbow off the stove's flue collar (Figure 1 vs. Figure 2). In all cases, however, the unit's minimum rear clearance to combustibles of 5" (127 mm) **must** always be maintained, regardless of the venting configuration (Figure 4).

For aesthetic reasons, some owners prefer to cover or "sleeve" the Sterling's standard 4" (102 mm) vent pipe (be it single wall pipe or Type B-1 vent) with 6" (152 mm) enameled (or black matte) stovepipe which matches the color of the Sterling. Sleeving the 4" (102 mm) vent pipe with 6" (152 mm) stovepipe is difficult if the vent pipe is configured as shown in Figure 1 as there is no practical way to support the weight of the 6" (152 mm) stovepipe at the 90° elbow immediately behind the stove. Use of the reduced clearance top exit adaptor, however, will provide a sturdy horizontal shelf which will support the weight of the 6" (152 mm) (aesthetic) stovepipe (Figure 14).

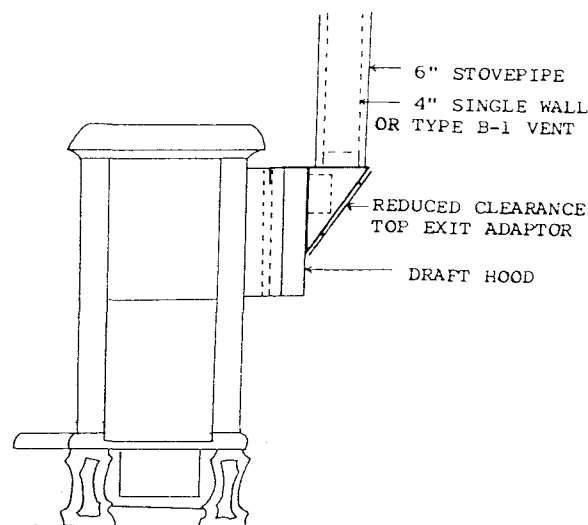

Figure 14 - Rear Clearance Top Exit Adaptor

HOW TO OBTAIN PARTS AND SERVICE

The Sterling is covered by a limited warranty for parts and labor for one year from the date of purchase. The door glass and enamel finish (if porcelainized) are not covered by the warranty. Read the warranty card supplied with the unit for complete details.

Replacement parts for the Sterling are available from your dealer or directly from the manufacturer, HearthStone®/NHC, Inc., PO Box 1069, Morrisville, Vermont 05661 USA. Telephone: 1-800-827-8683 (Continental US) or 802-888-5232.

This unit must be installed, adjusted, serviced and maintained by qualified service personnel only. Failure to properly install, adjust, service and maintain this gas appliance may result in an unsafe or hazardous condition which may lead to carbon monoxide poisoning, fire, explosion, personal injury and loss of life. Do not attempt to install, adjust, service or maintain this unit unless qualified to install, adjust, service or maintain gas-fired, vented appliances.

APPENDIX A - ELECTRICAL SCHEMATICS

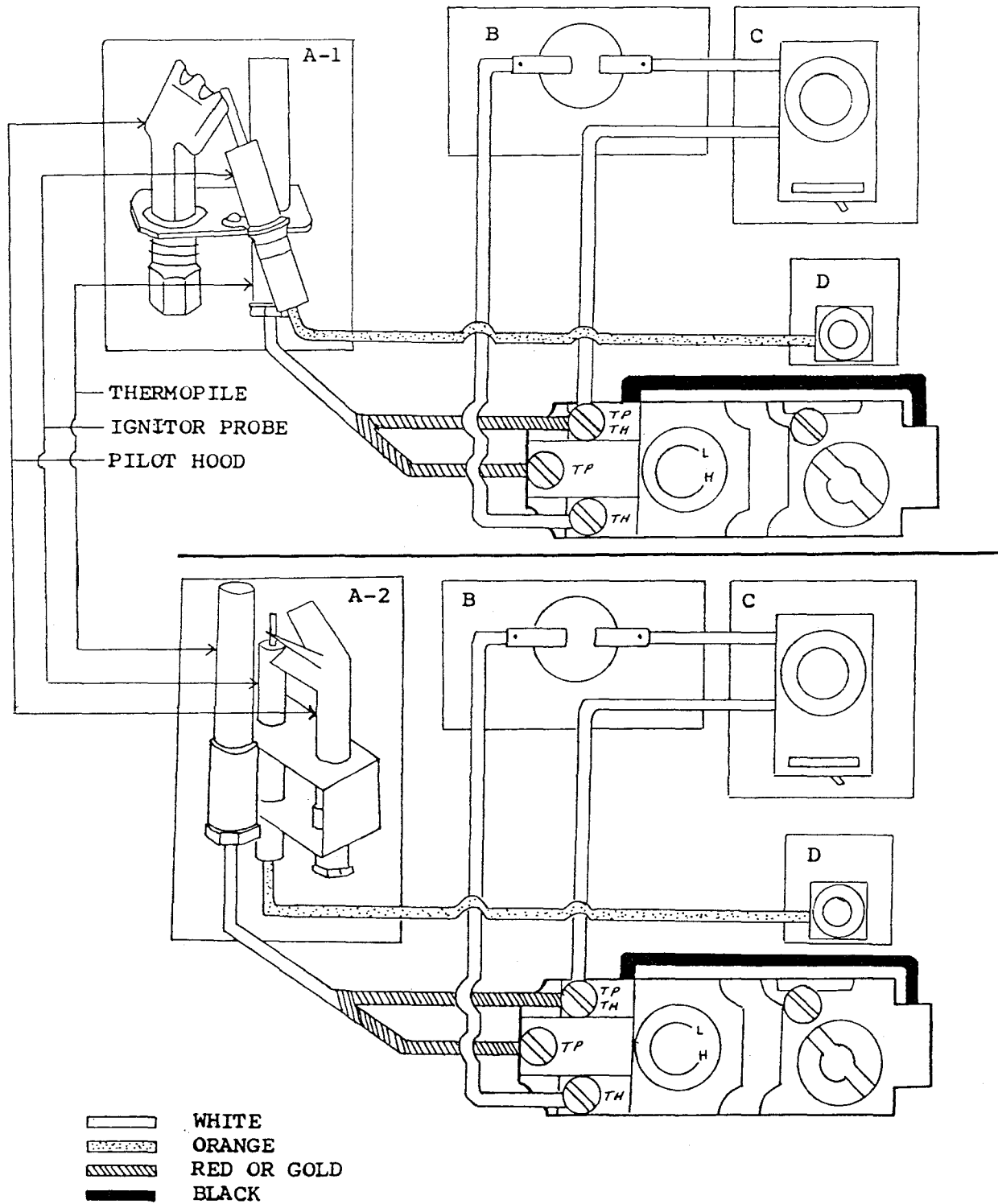

- A-1) Robertshaw Pilot Light Assembly (located in the firebox)
- A-2) White Rogers Pilot Light Assembly (located in the firebox)
- B) Spill Switch (located in the draft hood beneath the flue collar)
- C) Wall Thermostat
- D) Piezoelectric Spark Ignitor (located near the gas control valve)

APPENDIX B - SAFETY LABEL



LISTED GAS-FIRED VENTED ROOM HEATER
 MODEL: ■ STERLING MV ■ STERLING EL

NHC- WH-

TESTED TO: ANSI Z21.11.1 -1991, CAN1-2.1-M89
 AND CAN/CGA-2.17-M91

CERTIFIED FOR CANADA / HOMOLOGUÉ POUR LE CANADA
 THIS APPLIANCE MUST BE INSTALLED IN ACCORDANCE WITH LOCAL CODES, IF
 ANY; IF NOT, FOLLOW ANSI Z223.1-1992 (U.S. INSTALLATION) OR CURRENT CAN1-
 B149 INSTALLATION CODE (CANADIAN INSTALLATION).

U.S.	■ NATURAL GAS	■ LP
INPUT RATING (Btu/hr)0-610 m	41,000	41,000
INPUT RATING (Btu/hr)610-1370 m	40,000	38,000
ORIFICE SIZE 0-1370 m	31 DMS	50 DMS
MANIFOLD PRESSURE (in. w.c./kPa)	3.5/0.87	10.0/2.94
MAN. PRESSURE - LO SETTING (in. w.c./kPa)	0.9/0.22	2.7/0.67
MINIMUM INLET PRESSURE (in. w.c./kPa)	4.5/1.12	11.0/2.74
MINIMUM INPUT (Btu/hr)	20,000	18,000
MAXIMUM OUTPUT (Btu/hr)	31,000	31,600

MINIMUM CLEARANCES TO COMBUSTIBLE CONSTRUCTION:

DRAFT HOOD TO BACKWALL - 5"/127 mm
 DRAFT HOOD TO BACKWALL WITH SHIELD - 3"/76 mm
 EDGE OF TOP PLATE TO SIDEWALL - 3"/76 mm
 EDGE OF TOP PLATE TO DIAGONAL WALL - 3"/76 mm
 BOTTOM HEAT SHIELD MANDATORY.

OPTIONAL BLOWER: HOWARD INDUSTRIES 3-15-2541. ELECTRICAL RATING: 115
 VOLTS 1 AMPERE 60 HZ. NOT FOR USE WITH SOLID FUEL.

MANUFACTURED BY:

NHC, INC. • MORRISVILLE, VERMONT 05661

DO NOT REMOVE OR COVER THIS LABEL

For replacement of the following parts, contact your dealer or our customer service department at 1-800-827-8683.

<u>ITEM NO.</u>	<u>ITEM DESCRIPTION</u>
7200-103	FLUE SPILLAGE SWITCH
7200-A	GAS LOG SET
7200-B	GAS VALVE
5500-2416	SIDE RADIATION SHIELD
2510-402	BOTTOM CASTING
2510-403F	FRONT GRILL
2510-219	FRONT DOOR
2510-303	BOTTOM LEG
2510-413	SIDE LEG
2510-414	FIRE BAFFLE
3110-056	1/4" DOOR ROPE GASKETS
3160-080	3/4" WINDOW TAPE
5210-2321	THREADED ROD
6400-40441	OWNERS INFORMATION MANUAL
7200-C	ORIFICE AND ORIFICE ELBOW
7200-111	PILOT ELECTRODE ASSEMBLY
5500-2405	EXIT ASSEMBLY (HEAT EXCHANGER & DRAFT HOOD)
5500-2410	LOWER ASSEMBLY
1500-S/T	SIDE/TOP STONE (SPECIFY COLOR)
1500-F/B	FRONT DOOR BOTTOM STONE (SPECIFY COLOR)
1500-F/S	FRONT DOOR SIDE STONE (SPECIFY COLOR)
7200-D	BURNER TUBE
5500-2408	STONE CLIPS
5500-2416	TOP RADIATION SHIELD
5500-2404	FIREBOX
2510-401	TOP CASTING
2510-411	FRONT DOOR OUTER FRAME
2421-316	FRONT GLASS FRAME
3030-025	GLASS