



MODEL 1500 CATALYTIC EQUIPPED WOOD HEATER



MODEL 1500 WITH PEDESTAL



MODEL 1500 FIREPLACE INSERT

Owner's Manual

Safety, Installation, Operation, & Maintenance Guidelines

DO NOT DISPOSE OF THIS MANUAL



INSTALLER: Leave this manual with the individual (s) responsible for operating this wood heater.

OPERATOR: The Owner's Manual contains important safety, operating, and maintenance information. Please read and understand the entire Owner's Manual before installing or operating this wood heater. If you have questions please contact your High Valley Dealer for assistance.

SAVE THIS OWNER'S MANUAL FOR FUTURE REFERENCE

WARNING

HOT GLASS WILL CAUSE BURNS.
DO NOT TOUCH GLASS UNTIL COOLED.
NEVER ALLOW CHILDREN TO TOUCH GLASS.

NATIONAL FIREPLACE INSTITUTE

CERTIFIED
www.nficertified.org

We suggest that our woodburning hearth products be installed and serviced by professionals who are certified in the United States by the National Fireplace Institute® (NFI) as NFI Woodburning Specialists.

Safety Notice:

If this wood heater is not properly installed, a house fire may result.

For your safety, please carefully read and follow the installation directions. Contact the local Building Inspector, Fire Official, or other Authority Having Jurisdiction (AHJ) about code requirements, restrictions, and installation inspection in your area. The AHJ can advise you if you are required to obtain a permit before installation.

Failure to follow these instructions can result in property damage, bodily injury, or even death.



MODEL 1500 CATALYTIC EQUIPPED WOOD HEATER



Safety Tested by:
CONAM Inspection, Inc. AGTL | Natick, Massachusetts
Tested March 1988 to ANSI / UL 1482 Specifications

Emissions & Efficiency Tested by:
APEX Environmental Services, Inc. | Apex, NC 27502
Report 03.01.1994 | Tested to July 1990 Particulate Emission Standards

U.S. ENVIRONMENTAL PROTECTION AGENCY

Certified to comply with 2015 particulate emission standards.
Not approved for sale after May 15, 2020.

Under specific test conditions this catalytic equipped wood heater has been shown to deliver heat at rates ranging from 9,400 to 34,394 Btu/hr. Emissions were determined to be 3.4 g/hr. The default EPA efficiency rating for catalytic equipped heaters was 72% per the Federal Register, CFR - Title 40 - Part 60 - Subpart AAA, that was current at the time of testing. Results of CO (carbon monoxide) testing were not required nor recorded at that time. EPA validated CO and efficiency values will be published in future revisions of this manual, and on the High Valley website, as they become available.

This catalytic equipped wood heater has a manufacturer-set minimum low burn rate that must not be altered. This wood heater contains a catalytic combustor, which needs periodic inspection and replacement for proper operation. It is against federal regulations to operate this wood heater in a manner inconsistent with operating instructions in this manual, or if the catalytic element is deactivated or removed.

This catalytic equipped wood heater needs periodic inspection and repair for proper operation. Consult the maintenance section of this owner's manual for further information.

This catalytic wood heater is designed to burn natural wood only. Higher efficiencies and lower emissions generally result when burning air dried seasoned hardwoods, as compared to softwoods or to green or freshly cut hardwoods.

DO NOT BURN:

- Garbage;
- Lawn clippings or yard waste;
- Materials containing rubber, including tires;
- Materials containing plastic;
- Waste petroleum products, paints or paint thinners, or asphalt products;
- Materials containing asbestos;
- Construction or demolition debris;
- Railroad ties or pressure-treated wood;
- Manure or animal remains;
- Salt water driftwood or other previously salt water saturated materials;
- Unseasoned wood; or
- Paper products, cardboard, plywood, or particleboard. The prohibition against burning these materials does not prohibit the use of fire starters made from paper, cardboard, saw dust, wax and similar substances for the purpose of starting a fire in an affected wood heater.

Burning these materials may result in release of toxic fumes or render the heater ineffective and cause smoke.

Smoke Detectors should be installed on every floor of your home; in the living areas and especially near bedrooms. Many jurisdictions now require hard wired Smoke Detectors and/or Carbon Monoxide (CO) Detectors be installed in specific locations in single family homes. If you are not subject to such a requirement then, at a minimum, battery operated detectors should be installed. Test them regularly and install new batteries every six months. A smoke detector located in the same room as a wood heater should be installed as far away from the heater as possible to prevent accidental activation when lighting or refueling the fire. Smoke and CO detectors should be installed per the manufacturer's instructions and code requirements.

* New EPA regulations require that the efficiency of a wood heater be determined by test under laboratory conditions and expressed as a percentage using the HHV (Higher Heating Value) and/or LHV (Lower Heating Value) of cord wood to provide consumers a benchmark to use when comparing various models of wood heaters. Under the EPA Regulations all Wood Heaters will be retested by the year 2020 using the CSA B415.1-10 standard which will use weighted average of efficiencies achieved at different burn rates and will determine a CO value as part of the testing. To learn more, please visit www.highvalleystoves.com.

HIGH VALLEY STOVES BY STOLL
185 Highway 201 | Abbeville, SC 29620
www.highvalleystoves.com

This manual describes the installation, operation, and maintenance of High Valley Stoves Model 1500 catalytic equipped wood heater. This heater is certified to comply with the U.S. Environmental Protection Agency's crib wood emission limits for wood heaters sold after May 15, 2015.

Throughout this manual you will find important safety notices and information may be repeated a number of times. The repetition is intentional in an effort to reinforce safety instructions and to place them in context.

TABLE OF CONTENTS

U.S. EPA EMISSIONS & SAFETY TESTING INFORMATION	PAGE 2
GENERAL SAFETY INFORMATION & SAFETY PRECAUTIONS	Page 4
INSTALLATION PLANNING	PAGE 5
CHIMNEY PERFORMANCE	PAGE 6
CHIMNEY REQUIREMENTS & GUIDELINES	PAGE 7
CHIMNEY CLEARANCES & THIMBLE DETAILS	PAGE 8
MODEL 1500 FREESTANDING SPECIFICATIONS & CLEARANCES	PAGE 9
PRE-INSTALLATION ASSEMBLY	PAGE 10
FREESTANDING WOOD HEATER INSTALLATION	PAGE 11
FREESTANDING WOOD HEATER CONNECTION TO THE CHIMNEY	PAGE 12
MASONRY FIREPLACE INSTALLATION	PAGE 13
MODEL 1500 INSERT DIMENSIONS & SURROUND INSTALLATION	PAGE 14
PRE-OPERATION ADVISORY	PAGE 15
MODEL 1500 FEATURES & COMPONENTS	PAGE 15
OPERATION GUIDELINES	PAGE 16 & 17
TROUBLESHOOTING INFORMATION	PAGE 18
CATALYTIC INFORMATION AND THERMOMETER INSTALLATION	PAGE 19
CATALYTIC COMBUSTOR REMOVAL & CLEANING	PAGE 20
CATALYTIC COMBUSTOR DIAGNOSIS, REPLACEMENT & WARRANTY	PAGE 21
LOADING DOOR MAINTENANCE & FIREBOX PARTS	PAGE 22
CONVECTION BLOWER MAINTENANCE & PARTS	PAGE 23
APPENDIX A ~ BASICS OF WOOD COMBUSTION	PAGE 24
APPENDIX B ~ HEATING VALUES OF WOOD	PAGE 25
APPENDIX C ~ FLOOR & WALL PROTECTION	PAGE 25
WARRANTY COVERAGE	PAGE 26
OWNERS RECORD & SAFETY LABEL	PAGE 27

GENERAL SAFETY INFORMATION

Thank you for choosing a wood heater from High Valley Stoves. Safe and efficient operation of your wood heater depends greatly on proper installation as outlined in this owner's manual. If this wood heater is not properly installed, a house fire may result. To reduce the risk of fire follow all instructions, cautions, and safety notices contained herein. Installation must also meet all State and Local Code requirements and/or restrictions. Check with your local Building Official, Fire Official, or other Authority Having Jurisdiction (AHJ) regarding the need to obtain a permit prior to installing a wood heater; and whether an inspection of the installation is required upon completion. Understand that code requirements and follow-up inspection are not put in place to make the installation process more difficult. Rather they are designed to help ensure your safety. Don't take shortcuts, use or allow makeshift methods, or other compromises in the installation. Safety is paramount and the key to enjoying your new wood heater. Installation by an experienced professional installer who has the specialized knowledge, tools, and equipment to complete the installation safely is strongly recommended. Look for an installer who is certified by the The National Fireplace Institute (NFI) as a Woodstove Specialist or Master Hearth Professional (MHP) to have demonstrated their mastery of the knowledge required in all phases of safe woodstove installation, and of best current industry practices. Be sure to contact your insurance company to inquire whether they have additional requirements.

SAFETY PRECAUTIONS

BURN SOLID WOOD FUEL ONLY. This wood heater is designed and approved for the burning of cord wood fuel only. Burning any type of fuel other than cord wood in this wood heater is against all safety testing and will void all warranties.

DO NOT USE CHEMICALS OR FLUIDS TO START THE FIRE. Never use gasoline, gasoline-type lantern fuel, kerosene, charcoal lighter fluid, or similar liquids to start or "freshen up" a fire in this wood heater. Keep all such liquids well away from the heater at all times. Storing these or other flammable liquids near a wood heater could cause a fire.

DO NOT BURN GARBAGE OR FLAMMABLE FLUIDS SUCH AS GASOLINE, NAPHTHA OR ENGINE OIL. Cord wood is the only fuel approved for use in this wood heater.

DO NOT CONNECT THIS UNIT TO A CHIMNEY FLUE SERVICING ANOTHER APPLIANCE.

DO NOT CONNECT A WOOD HEATER TO, OR USE IN CONJUNCTION WITH, ANY AIR DISTRIBUTION DUCTWORK UNLESS SPECIFICALLY APPROVED FOR SUCH INSTALLATIONS.

DO NOT OPERATE IN AN EXTREME MANNER AS TO OVER-FIRE THE WOOD HEATER. If any part of the wood heater, the chimney, or the chimney connector glows, you are over-firing. If over-firing occurs, close all combustion air controls immediately. Over-firing and/or attempts to achieve heat output rates that exceed heater design specifications can result in permanent damage to the heater, and to the catalytic combustor, and may cause a fire.

HOT WHILE IN OPERATION. KEEP CHILDREN, CLOTHING, AND FURNITURE WELL AWAY. CONTACT MAY CAUSE SKIN BURNS. Observe all minimum clearances as listed in this manual. Maintain a 36" area around the wood heater to be kept free of combustible materials including furniture and window treatments. **DO NOT** allow unattended children in the area of an operating wood heater.

BURN DIRECTLY ON FIRE BRICKS. Do not use grates, andirons, or other methods to support fuel.

FUEL STORAGE. Store bulk cord wood covered in a well ventilated area to ensure that the wood fuel is as dry as possible. Do not store wood fuel within wood heater minimum clearances or within the space needed for loading the heater or for ash removal.

ASH DISPOSAL. Ashes should be placed in a steel container with a tight-fitting lid and moved outdoors immediately. The closed container of ashes should be placed on a non-combustible floor or on the ground, well away from all combustible materials, pending final disposal. If the ashes are disposed of by burial in soil or otherwise locally dispersed, they should be retained in the closed container until all cinders have thoroughly cooled. Other waste shall not be placed in this container.

CREOSOTE FORMATION & REMOVAL.: Inspect chimney connector and chimney twice monthly, and clean if necessary. Creosote accumulation in the connector pipe, chimney, or flue lining can create an extremely hot fire if ignited.

INSTALLATION PLANNING

Your new High Valley wood heater has been designed to give you years of clean, efficient service. Take time to consider carefully where your new wood heater will be installed in your home. If you are planning to use an existing chimney and/or hearth, many of the decisions have been made for you. Consult with your High Valley dealer before committing to a final location and take full advantage of their experience. Consider how you plan to use your wood heater, your expectations, and the physical layout of your home. Once the wood heater has been installed it would require significant effort and expense to change its location. Perhaps, after considering all factors, you may come to the conclusion that the location of an existing chimney may not be the best place for your new wood heater. Evaluate all of your options fully before making a final decision.

LOCATION: The wood heater should be located in a place where it will be convenient to fuel and maintain the fire, but well away from human traffic flow, and clear of hallways and doors. It must be possible to maintain the minimum clearances to combustibles which were determined by safety testing. See **Page 9**. Ensure that furniture, window treatments (draperies, curtains, etc.), wood materials including wood fuel, and any other combustible materials will be no closer than 36" to the wood heater. If children reside in the home, or visit regularly, consider how the area immediately around the heater can be closed off to keep the children safely away from hot surfaces. Consult your High Valley dealer for advice on safety gates and other safety products.

HEATING CONSIDERATIONS: Ideally the wood heater will be centrally located in the area that you wish to heat. A wood heater is an excellent area heater or space heater. Properly sized and operated it will heat the area where it is located and heated air will naturally move throughout the home. Keep in mind that a wood heater does not have the advantage of a distribution system to deliver the heat around your home like a central heating boiler or furnace. Don't expect the type of even heat distribution that a central heating system can deliver. If your goal is to heat a family room, an addition, or a portion of the main house, the heater should be sized and operated to create a warm, comfortable space with the surplus heat allowed to travel around the home on natural convection (air) currents. A large wood heater with the capacity to heat a home will typically overheat the area where it is located unless the home is constructed with an open floor plan. If heating a typical partitioned home with wood as a primary heat source is truly the goal, then it would be wise to consider installing a number of smaller sized wood heaters throughout the space to be heated rather than a single large wood heater. The number would depend on the size and layout of the home. Installing your wood heater in an uninsulated basement is not recommended. Much of the heat produced will be lost to the uninsulated walls of the basement. Never cut holes or vents in a ceiling/floor in an attempt to get warm air to rise to the rooms above. You will be compromising a firebreak in your home and could, should a fire ensue, jeopardize your homeowner's insurance coverage. Contact your local Building Official, Fire Official, or other Authority Having Jurisdiction for guidance.

CHIMNEY LOCATION: Once the best physical location for your wood heater from a heating perspective is agreed upon, the feasibility of providing a safe and effective chimney in that location must be considered. If the chimney is to run up through the ceiling and/or the roof then the space above must be clear. The layout and location of floor joists and/or roof rafters must be ascertained. Most factory-built chimney components are designed to fit into standard construction without the need for cutting and boxing frame members. A factory-built chimney can also exit through the sidewall of the house and up the side of the home. Another alternative would be to construct a new masonry chimney specifically for the wood heater. In any case, the wood heater must not be vented into a chimney flue serving any other appliance. Once again, it is strongly recommended that the chimney installation be performed by a certified professional installer who is thoroughly familiar with the requirements of modern wood heaters.

Your High Valley Model 1500 is approved for installation into either a masonry chimney or a Type HT factory-built chimney listed to UL-103-HT or ULC-S629 standards. A masonry chimney is a permanent installation requiring a load bearing footing to support the mass of the chimney. Factory-built chimneys offer flexible installation options and use proprietary support systems for through-the-roof or sidewall installation. A properly constructed chimney that provides adequate draft is essential for the safe and efficient operation of your wood heater. More specific information about draft and various chimney installations and material will follow, but lets begin at the beginning. Look back to a time when fireplaces, woodstoves, and later, solid fuel central heating were relied on as the only source of heat in cold weather. Proper chimney construction and location could spell the difference between keeping warm in the winter and not. Those chimneys had to work. Life revolved around the fireplace and, later, the cook stove and parlor stove. The chimney was typically built in the center of the home where it helped warm the home and it, in turn, was kept warm by the home. The central location ensured that the chimney would exit near the peak of the roof and therefore be as tall as possible. Our ancestors knew from experience that a tall, warm chimney would draft better and was less likely to be affected by wind and weather. The same principals apply today.

CHIMNEY PERFORMANCE

Chimneys that were constructed in homes built before the advent of oil and gas-fired central heating systems were invariably constructed within the walls of the home, typically centrally located, and exited the roof at or near the ridge. The principals that applied then apply today. A chimney is best located within the envelope of the home to keep it warm, and it should be installed as close to the peak of the roof as possible. If you have a modern fireplace that was constructed with the chimney outside the home, exposed to the cold, and with a relatively short chimney, it may not be your best choice for use with a modern, efficient wood heater. As central heating became prevalent, fireplaces and their chimneys were moved outside the walls of the home to conserve floor space. If they didn't draft well it was not considered a major problem because the central heating system kept the home warm.

DRAFT: The Environmental Protection Agency defines draft this way: "Draft is the force which moves air from the appliance up through the chimney." Simply stated, heated air (wood heater exhaust or any heated gas for that matter) becomes more buoyant and tends to rise. The hotter the gasses contained in a chimney flue are, compared to the temperature of the air outside, the greater the draft should be. There are many variables and the scientific explanation can become complicated. (There are books and scientific papers written for those who would like to know more.) Suffice to say that you need it. Without adequate draft your wood heater cannot burn efficiently nor vent smoke properly. The draft of the chimney provides the suction that pulls air into the wood heater to support combustion. A wood heater provided with adequate draft cannot leak smoke, as air is being drawn into the heater, connector pipe, and chimney. If a wood heater is leaking smoke or spills a lot of smoke during refueling, inadequate draft is most likely the culprit.

A complete explanation of all of the elements that may affect draft are beyond the scope of this manual but, briefly, some factors that contribute to a properly drafting chimney are these:

- **FLUE SIZE:** It is recommended that the flue size of the chimney be the same size as the flue outlet on the heater. Theoretically a larger chimney flue should have a greater flow capacity than a smaller flue. In practice however, the heated flue gases are diluted by the extra air in the larger flue and cool faster. Draft is decreased therefore and, if cooled too much, creosote may be deposited in the flue. The Model 1500 has an eight inch (8") flue collar and 8" factory-built HT chimney is the preferred option and is readily available. An existing masonry chimney can be more challenging, depending on the flue size. If the existing masonry chimney has a single eight inch (8") square masonry flue tile, it is only slightly larger than the 8" flue of the Model 1500, and can be an acceptable option, assuming that the masonry chimney provides adequate draft. (The cross sectional area of an 8" round flue is 50% sq. in. {Area = πr^2 or $A = \pi 4^2$ or $A = 3.14 \times 16$ } where Pi = 3.1416} The cross sectional area of an 8" square masonry flue tile is @ 64 sq. in.) However, masonry chimneys commonly have 8" x 12" (@96 sq. in.) or even 12" x 12" (@144 sq. in.) flue tiles, which would be two (2X) to three times (3X) larger than the Model 1500 flue outlet, and may draft poorly. In addition, masonry construction tends to cool more quickly with cold outside temperatures. If a new masonry chimney is being constructed, ask the mason to source 8" round flue tiles. They are available and can be insulated with vermiculite or other approved chimney insulation materials. The performance of an existing masonry chimney may be improved significantly with the installation of an insulated chimney liner that is the same size as the flue outlet of the wood heater.
- **INSULATION:** A chimney flue that is kept warm is more likely to draft well than a cold chimney. Keeping the chimney within the walls of the home is the best solution if space allows. If the chimney must be constructed outside the home, then insulating the chimney is strongly recommended. Factory-built HT chimneys are packed with insulating material and can be further protected by installing them inside an insulated chimney chase (enclosure) outside the home. Masonry chimneys may require an insulated flue liner to provide adequate draft in all seasons. Consider that when it is cold (20 degrees for example) outside the home, the air inside the flue of an outdoor chimney will be essentially the same temperature. When lighting the fire it will be necessary to provide enough heat to overcome that column of cold air acting like a plug in the chimney flue. Even after the wood heater has been ignited and is burning, a cold chimney can still have a negative effect on draft. Hot flue gasses cool more quickly in a chimney exposed to the elements; perhaps to the point where the draft becomes inadequate to maintain an efficient fire.
- **HEIGHT:** A tall chimney is more likely to draft well than a short chimney. The taller column of heated gas creates a greater temperature and pressure differential with the outside atmosphere and better draft is the result. As above, the flue size and insulation also play significant roles in the process. A minimum chimney height of @ ten feet (10') and a maximum height of @ thirty feet (30'), measured from the top of the wood heater, is recommended. Locating the chimney where it will project above the ridge of the roof, rather than near the eaves of the home, will net the tallest chimney height practical for your home. External elements like tall trees, hills, tall buildings, and the like can affect draft when the wind is blowing from a particular direction. Locating a short chimney at the eaves of the home may result in draft problems when the wind blows across your own roof ridge. Height alone is not the only factor to consider when specifying a chimney but, in general, taller is better.

CHIMNEY REQUIREMENTS

Your High Valley Model 1500 must be connected to either a factory-built Type HT chimney or to a masonry chimney with a flue liner of a construction that meets all current code requirements. If the wood heater is to be connected to an existing chimney, have the chimney inspected prior to installing the wood heater by an NFI certified hearth installer, a CSIA chimney sweep, or a qualified mason in the case of a masonry chimney. The chimney must prove to be sound and serviceable and to meet all applicable codes. An existing factory-built chimney must be Type HT, listed to UL-103-HT or ULC-S629 standards. An existing masonry chimney must have a clay tile liner or approved stainless steel insulated liner. The wall thimble or pass-through construction should be inspected to ensure it conforms to current NFPA 211 guidelines. The flue size must not be less than the flue collar or greater than three times (3X) the cross-section of the flue collar. NOTE: An oversize masonry chimney may not prove to provide adequate draft and may require the installation of an insulated liner approved to UL 1777 to function satisfactorily.

If a new chimney is to be constructed to vent the wood heater we strongly advise that the chimney be professionally installed. Factory-built chimney must be Type HT-2100°F tested to the UL 103 standard and/or ULC S629 standard. An eight inch (8") diameter factory-built chimney is preferred. All components of the factory-built chimney must be from the same manufacturer and be of the same type to ensure proper connection of components. All chimney components needed for the installation including but not limited to wall pass-throughs, tees and tee supports, ceiling supports, insulation shields, fire stops, roof support packages, roof flashings, chimney caps, etc. must be installed exactly to the manufacturer's instructions. Installation specification and clearances may vary from manufacturer to manufacturer and must be carefully adhered to according to the individual manufacturer's instructions.

If a new masonry chimney is to be constructed, the use of a professional masonry contractor is strongly recommended. Specialized knowledge is needed to ensure proper construction and support for a masonry chimney. The chimney must be constructed in accordance with the latest edition of NFPA standard 211 and must conform to all applicable state and local codes. Wall thimble construction and clearances to combustibles must meet NFPA 211 guidelines. A permit and inspection may be required by the local Building Official, Fire Official, or other Authority Having Jurisdiction. An eight inch (8") round or 8" x 8" square flue tile is required. The flue tiles must be mortared together with the approved material and provided with an air space as required by NFPA 211 and applicable codes. It is recommended that the masonry flue tiles be well insulated with a material approved for the purpose.

CHIMNEY GUIDELINES

The following information about chimney construction and requirements is intended for reference only. The use of a professional installer is strongly recommended. Specific installation instructions and/or requirements must conform to the chimney manufacturer's instructions and/or applicable building codes. Seek the advice of your High Valley Dealer and/or the local Authority Having Jurisdiction as to local code, permitting, and inspection requirements.

CHIMNEY HEIGHT

- The top of the chimney must be at least two feet (2' or 0.6m) taller than the highest point of the roof or any part of the roof or other structure within ten feet (10' or 3m) measured horizontally from the chimney termination.
- The chimney must be at least three feet (3' or 0.9m) taller than the high side of the roof penetration.

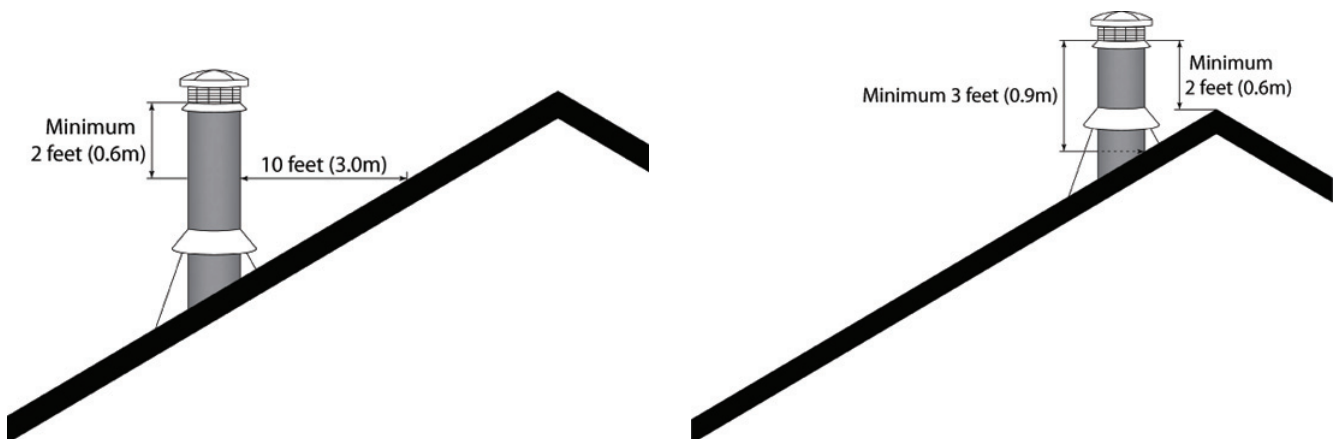

CHIMNEY CLEARANCES & THIMBLE DETAILS

CHIMNEY CLEARANCES

- Special care must be exercised to ensure that all chimney clearances to combustibles meet current standards.
- Existing chimneys should be inspected to ensure that clearances to combustibles are in compliance.
- Factory-built chimney clearances are defined in the manufacturer's installation instructions.
- Masonry chimney clearances to combustibles are described in the current NFPA standard 211.
- Clearances to combustibles may vary for indoor and outdoor installations.

CHIMNEY THIMBLE DETAILS

- Special construction techniques are required to ensure safe connection to a chimney through a combustible wall.
- Refer to the current version of NFPA standard 211 and obtain the approval of the local Authority Having Jurisdiction.

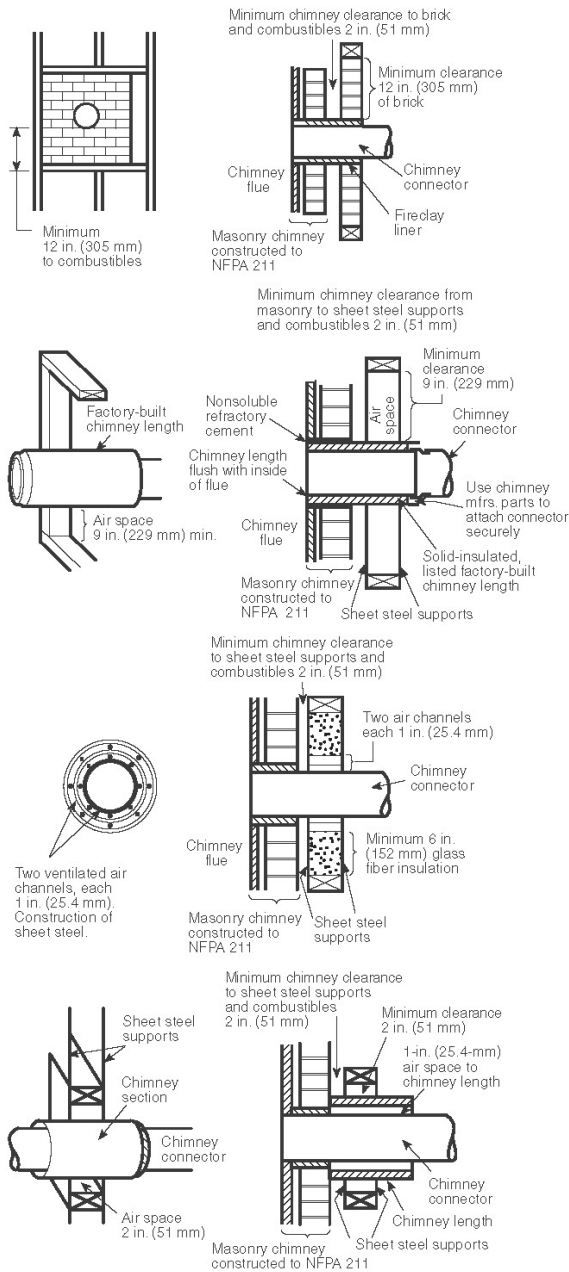

- Minimum 3.5 inch (90mm) thick brick masonry wall framed into combustible wall with a minimum of 12 inch (305mm) brick separation from clay liner to combustibles. Fireclay liner (ASTM C 315, Standard Specification for Clay Fire Linings, or equivalent), minimum $\frac{5}{8}$ inch (16mm) wall thickness, shall run from outer surface of brick wall to, but not beyond, the inner surface of chimney flue liner and shall be firmly cemented in place.
- Solid-insulated, listed factory-built chimney length of the same inside diameter as the chimney connector and having 1 inch (25.4mm) or more of insulation with a minimum 9 inch (229mm) air space between the outer wall of the chimney length and combustibles. The inner end of the chimney length shall be flush with the inside of the masonry chimney flue and shall be sealed to the flue and to the brick masonry penetration with non-water-soluble refractory cement. Supports shall be securely fastened to wall surfaces on all sides. Fasteners between supports and the chimney length shall not penetrate the chimney liner.
- Sheet steel chimney connector, minimum 24 gauge [0.024 inch (0.61 mm)] in thickness, with a ventilated thimble, minimum 24 gauge [0.024 inch (0.61mm)] in thickness, having two 1 inch (25.4mm) air channels, separated from combustibles by a minimum of 6 inches (152mm) of glass fiber insulation. Opening shall be covered, and thimble supported with a sheet steel support, minimum 24 gauge [0.024 inch (0.61mm)] in thickness. Supports shall be securely fastened to wall surfaces on all sides and shall be sized to fit and hold chimney section. Fasteners used to secure chimney section shall not penetrate chimney flue liner.
- Solid-insulated, listed factory-built chimney length with an inside diameter 2 inches (51mm) larger than the chimney connector and having 1 inch (25.4mm) or more of insulation, serving as a pass-through for a single wall sheet steel chimney connector of minimum 24 gauge [0.024 inch (0.61mm)] thickness, with a minimum 2 inch (51mm) air space between the outer wall of chimney section and combustibles. Minimum length of chimney section shall be 12 inches (305mm). Chimney section concentric with and spaced 1 inch (25.4mm) away from connector by means of sheet steel support plates on both ends of chimney section. Opening shall be covered, and chimney section supported on both sides with sheet steel supports of minimum 24 gauge [0.024 inch (0.61mm)] thickness. Supports shall be securely fastened to wall surfaces on all sides and shall be sized to fit and hold chimney section. Fasteners used to secure chimney section shall not penetrate chimney flue liner.

ADDITIONAL REQUIREMENTS:

- Insulation material used as part of wall pass-through system shall be of noncombustible material and shall have a thermal conductivity of 1.0 Btu-in./hr-ft $^{\circ}$ F (4.88 kg-cal/hr-m $^{\circ}$ C) or less.
- All clearances and thicknesses are minimums; larger clearances and thicknesses shall be permitted.
- Any material used to close up an opening for the connector shall be of noncombustible material.
- A connector to a masonry chimney, except for System B, shall extend in one continuous piece through the wall pass-through system and the chimney wall to the inner face of the flue liner, but not beyond.

MODEL 1500 FREESTANDING SPECIFICATIONS & CLEARANCES

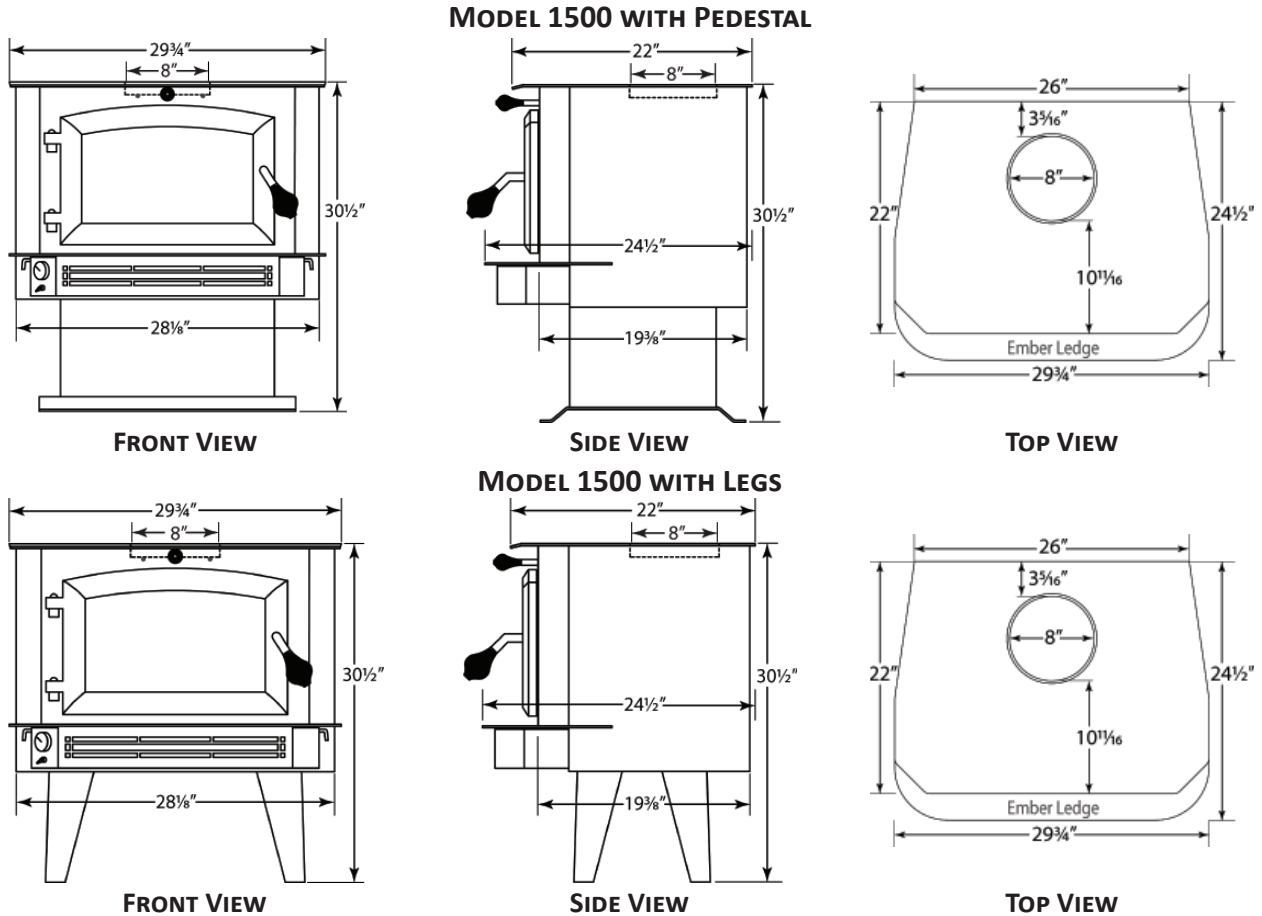

Model 1500 Over All Width: 29 3/4"	Flue Size: 8"
Model 1500 Over All Depth: 24 1/2"	Firebox Volume: 2.5 cu. ft.
Model 1500 Height with Pedestal: 30 1/2"	Firebox Dimensions: 22 1/2" wide x 16 1/2" deep
Weight: 386 lbs.	Maximum Log Length: 21"

MINIMUM CLEARANCES TO COMBUSTIBLES MEASURED FROM THE BODY OF THE WOOD HEATER

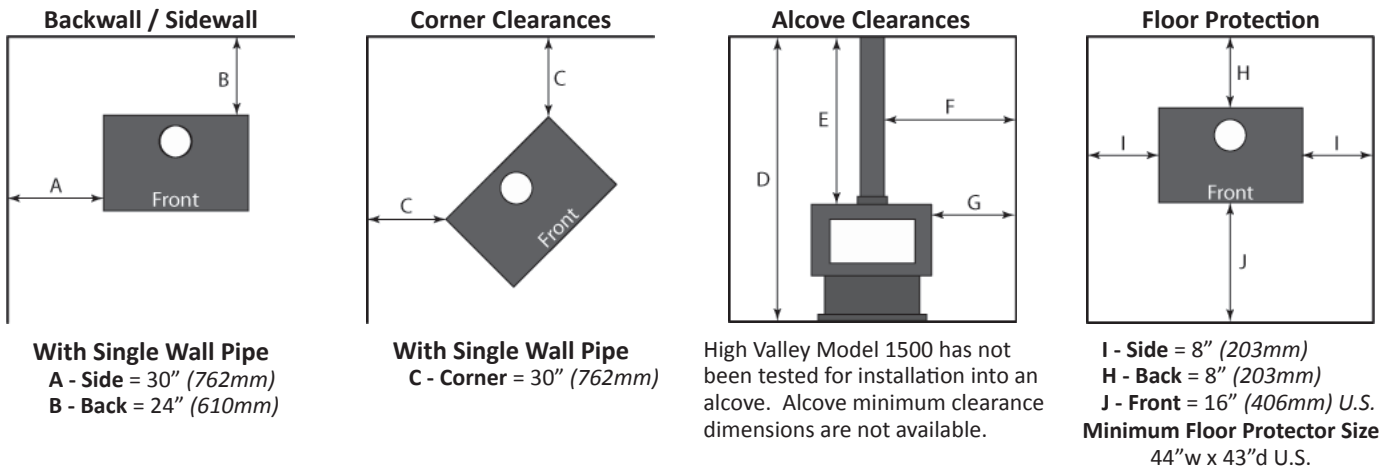

FLOOR PROTECTION:

FLOOR PROTECTION: Use UL 1618 Type 2 R = 0.45 - "3/8" Asbestos Millboard or Equivalent" with k = 0.84

NOTE: Clearances to combustible materials may be reduced using shielding methods as described in the current edition of NFPA 211 Standard for Chimneys, Fireplaces, Vents, and Solid Fuel Burning Appliances. Any reduction of clearances must be approved by the local Authority Having Jurisdiction.

PRE-INSTALLATION ASSEMBLY

CAUTION

- If this wood heater is not properly installed, a house fire may result. To reduce the risk of fire follow all instructions, cautions, and safety notices contained herein.
- Installation must also meet all State and Local Code requirements and/or restrictions. Check with your local Building Official, Fire Official, or other Authority Having Jurisdiction (AHJ) regarding the need to obtain a permit prior to installing a wood heater; and whether an inspection of the installation is required upon completion.
- Don't take shortcuts, use or allow makeshift methods, or other compromises in the installation. Safety is paramount and the key to enjoying your new wood heater.
- Installation by an experienced professional installer who has the specialized knowledge, tools, and equipment to complete the installation safely is strongly recommended. Look for an installer who is certified by the The National Fireplace Institute (NFI) as a Woodstove Specialist or Master Hearth Professional (MHP) to have demonstrated their mastery of the knowledge required in all phases of safe woodstove installation, and of best current industry practices.
- Be sure to contact your insurance company to inquire whether they have additional requirements.

INSPECTION: Your High Valley wood heater was inspected before being packaged at the factory. Chances are that your High Valley Dealer has un-boxed and assembled your wood heater prior to delivery. Your dealer has the equipment and the experience to handle heavy appliances. If you have taken delivery of your wood heater in the box, proceed as follows:

- Carefully remove the shipping materials. Use caution. The contents are heavy.
- Carefully inspect the Model 1500 and accessories, if any, for signs of damage.
- If any damage is noted or suspected please contact your High Valley Dealer for assistance.
- DO NOT proceed with installation until the wood heater has been inspected and replacement parts obtained.

INSTALLATION OF LEGS OR A PEDESTAL: If your Model 1500 was not assembled before delivery, the pedestal base or legs must be fastened securely to the body. (Disregard this step for a fireplace insert application.)

USE EXTREME CAUTION. The wood heater is very heavy. At least two strong individuals will be needed to lift the heater body for assembly. Personal injury and/or damage to the wood heater or personal property may result if the heater is handled improperly. If you have concerns about handling the heater please contact your dealer for assistance.

MATERIALS INCLUDED: Heater Body, Leg Kit or a Pedestal Base, four (4) each 3/8" - 16 x 1" bolts, Owner's Manual.

• LEG INSTALLATION:

NOTE: It is strongly recommended that Cast Iron or Steel Legs be installed by your High Valley dealer. The body of the Model 1500 must be lifted at least 12 inches (12") and supported in this position while the legs are attached. Your dealer has the material handling equipment and experience to handle the weight of the Model 1500. Laying the Model 1500 on its back to install the legs is not recommended. Leg breakage can occur as the assembled wood heater is being tipped upright. (If you opt for this method, remove the firebricks that line the firebox before tipping the body.) Carefully lift the wood heater body onto sturdy blocks or jacks capable of supporting the weight of the body.

- Assemble the four legs to the body using the 3/8 -16 x 1" bolts provided. Tighten each leg securely.
- Carefully lift the assembled heater, remove the blocking of jacks, and gently set the heater onto the legs.

CAUTION: Never slide the wood heater into position. It must be lifted or damage to the legs may result.

• PEDESTAL BASE INSTALLATION:

- Place the un-boxed pedestal on the floor close to where the wood heater will be installed. Place a piece or pieces of cardboard under the pedestal base to protect the floor while assembling the Model 1500.
- Carefully lift the Model 1500 body and set it down gently top of the pedestal; taking care that it is centered.
 - Do not drop the body onto the pedestal base. Damage to the floor or the floor protector may result.
- Align at least one of the holes in the pedestal with the corresponding threaded hole in the heater body.
 - Insert one of the 3/8 -16 x 1" bolts through the hole in the pedestal base and into the threaded hole in the bottom of the body. Tighten finger tight only at this stage. Pivot the heater body carefully on the pedestal base to align the remaining three bolt holes and fasten with the remaining bolts.
- Tighten the four (4) bolts securely using a 9/16" or 14mm wrench, an adjustable wrench, or similar tool.

FLUE COLLAR INSTALLATION: An 8" flue collar is included with the Model 1500 to provide for secure connection of the connector pipe. An 8" to 6" reducer is available as an option to the standard 8" flue collar. Consult you dealer.

The flue collar fastens with four (4) 1/4-20 bolts (provided) into four corresponding holes in the top of the wood heater. Tighten the four bolts evenly and securely. If it is anticipated that the flue collar may be removed for future service, such as in a fireplace installation, high temperature anti-sieze compound applied to the bolts will ease disassembly. In a fireplace insert installation the flue collar can be assembled to the liner first, and then fastened to the wood heater.

CONVECTION BLOWER INSTALLATION: The Convection Blower is a standard feature on the Model 1500 which helps move heated air into the home. The Convection Blower and cover are pre-mounted and wired at the factory, ready for use. If repair or replacement of the blower is required a wiring diagram is provided on **Page 23**.

FREESTANDING WOOD HEATER INSTALLATION



We suggest that our woodburning hearth products be installed and serviced by professionals who are certified in the United States by the National Fireplace Institute® (NFI) as NFI Woodburning Specialists.

If this wood heater is not properly installed, a house fire may result. To reduce the risk of fire follow all instructions, cautions, and safety notices contained in this manual.

Do not take shortcuts. Do not use or allow makeshift methods or other compromises in the installation. Safety is the key to enjoying your wood heater responsibly.

FLOOR PROTECTOR INSTALLATION

- The Model 1500 requires UL 1618 Type 2 Thermal Protection R = 0.45 - "3/8" Asbestos Millboard or Equivalent" with $k = 0.84$ or a continuous non-combustible material that meets the dimensions listed on **Page 9**. Brick or tile must be mortared and grouted to present a continuous surface, not "loose laid." If a hearth or floor protector is to be site-built, or an existing hearth is to be utilized, the condition and thermal resistance must be determined to ensure the minimum requirements are met. See Appendix - C on **Page 25**.
- Minimum floor protection must be continuous under the wood heater and 8 inches (8") to the back and each side, and sixteen inches (16") in front of the loading door. The minimum size is 44"w x 43"d in the U.S.
- Floor protection must extend under any horizontal section of connector pipe and at least two inches (2") to each side.
- It is recommended that you use a floor protector that is larger than minimum size; large enough to cover the flooring to the wall in the rear, and to provide extra non-combustible working space for a metal ash container, tools, gloves, etc.

WOOD HEATER INSTALLATION

- With the floor protection in place, carefully move the Model 1500 into position.
- Use extreme caution when lifting the Model 1500; it is **very heavy**. The use of lifting straps (furniture moving straps) by at least two, or more, strong individuals is recommended. Personal injury and/or damage to the wood heater or personal property may result if the wood heater is handled improperly. If you have concerns about handling the wood heater please contact your High Valley dealer for assistance.
 - Lift the wood heater and gently set it in place. Do not drop the wood heater onto the floor protector. Do not slide the wood heater into position. Damage to the floor protection may result. Setting the wood heater onto pieces of heavy cardboard will minimize the possibility of scratching the floor protection and allow final positioning of the wood heater. Remove the cardboard before lighting the first fire in the wood heater.
- The wood heater should be centered on the chimney if possible to allow for the shortest and most direct connection. The wood heater does not necessarily need to be centered on the floor protection as long as the minimum side protection requirement (8") is met. An asymmetrical installation may provide more usable space to one side.
- The wood heater and floor protector must be positioned to maintain at a minimum the clearances to combustibles as shown in the chart on **Page 9** of this manual and on the safety label affixed to the wood heater.
- Clearances to combustible materials may be reduced if needed by using shielding methods as described in the current edition of NFPA 211 Standard for Chimneys, Fireplaces, Vents, and Solid Fuel Burning Appliances. Any reduction of tested clearances must be approved by the local Authority Having Jurisdiction (AHJ).

CONNECTOR PIPE REQUIREMENTS

- Before connecting the wood heater to a factory-built or masonry chimney, have the chimney inspected to ensure that it is properly installed, clean, and in good repair. Have the chimney cleaned if necessary.
- Do not pass a chimney connector pipe through any combustible wall (s) or ceiling (s). Special methods are required when passing a chimney through any combustible wall, ceiling, or roof. Ensure that all chimney clearance requirements are met and all penetrations through combustible walls and/or ceilings meet manufacturer's installation requirements, NFPA 211, and/or applicable code requirements. See **Pages 8 & 9** for additional information.
- **DO NOT CONNECT THIS WOOD HEATER TO A CHIMNEY FLUE THAT IS SERVICING ANOTHER APPLIANCE.**
- Use eight inch (8") (152mm) diameter (or six inch (6") (203mm) diameter with the use of a High Valley 8" to 6" adapter P/N: FLUCOL-86) minimum 24 MSG black steel connector pipe or pipe of a greater gauge.
- Use three (3) #10 sheet metal screws to fasten each section of connector pipe together and to secure the connector pipe to the flue collar of the wood heater. The length of the screws should be long enough to penetrate both sections of pipe (@ ¼") or the flue collar and pipe (@ ½") but not overly long.
- Crimped connector pipe ends should point away from the chimney and toward the wood heater flue collar.
- Connector pipe should be kept as short and straight as possible. Extra pipe and extra elbows can impede the flow of flue gasses and may cool the flue gasses to a point that negatively affects draft.

FREESTANDING WOOD HEATER CONNECTION TO THE CHIMNEY

CONNECTOR PIPE INSTALLATION:

Making the connection of a wood heater to a chimney falls into two general categories; vertical or horizontal venting. Within those general types there can be many variations. It is beyond the scope of this manual to describe all types and configurations of chimney installation. Rather, this section focuses on the connection of the wood heater to an approved chimney.

- Any existing chimney system, masonry or factory-built, should be inspected by your High Valley dealer or a professional chimney sweep to ensure that it meets all code requirements and is in sound and serviceable condition before connecting the wood heater. Seek the advice of the local building inspector or other Authority Having Jurisdiction. Particular attention should be paid to clearances to combustible materials, ceiling and/or roof penetrations, or wall thimbles.
- New factory-built chimney systems must be installed to the manufacturer's instructions and specifications. New masonry chimneys must meet the requirements of NFPA 211. All chimneys should be inspected before use. See **Pages 7 & 8**.

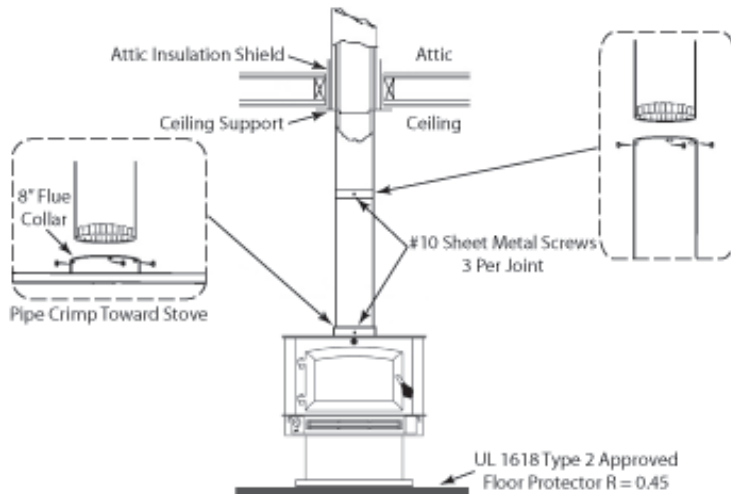

VERTICAL CONNECTOR PIPE INSTALLATION ILLUSTRATION *

VERTICAL CONNECTOR INSTALLATION

USING SINGLE WALL PIPE

- Center the wood heater flue collar directly under the chimney pipe if possible. All Clearances to combustibles must be maintained.
- Confirm that any ceiling support, roof support, fire-stops, insulation shields, etc. are installed correctly and match the brand of Type HT 2100° chimney being used.
- If the wood heater must be offset from the chimney opening, use 15° or 45° pipe elbows to make corrections for the offset.
- Crimped connector pipe ends must point downward toward the wood heater flue collar.
- Secure each pipe section to each other and the flue collar using three (3) #10 sheet-metal screws. See **Page 11**.

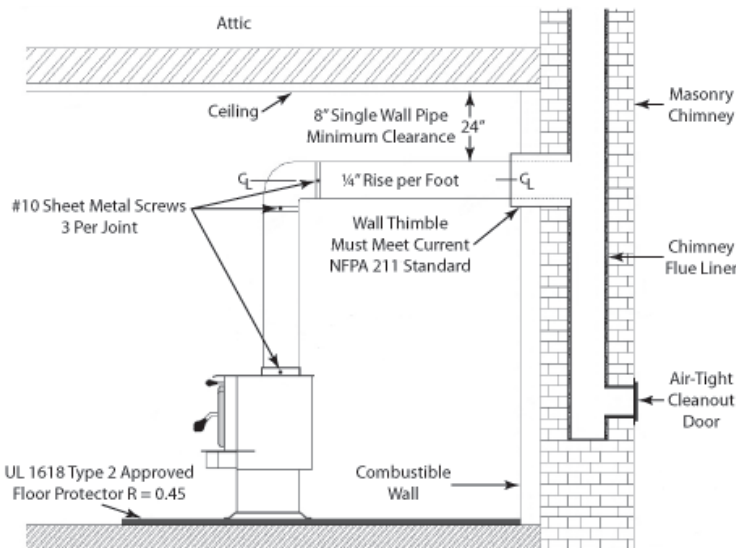

HORIZONTAL CONNECTOR PIPE INSTALLATION ILLUSTRATION *

HORIZONTAL INSTALLATION

USING SINGLE WALL PIPE

- Center the wood heater flue collar in line with the wall thimble if possible. All Clearances to combustibles must be maintained.
- Confirm that the factory-built wall pass through or masonry thimble meets manufacturer instructions and/or NFPA 211. See **Page 8**.
- Limit the 90° bends to one (1) elbow and the 90° bend where the thimble meets the flue.
- Maintain at least 24" clearance from 8" single wall connector (18" clearance from 6" single wall connector) to the ceiling.
- Floor protection must extend under horizontal section of connector pipe and at least two inches (2") to each side.
- Maintain 1/4" rise per foot in horizontal pipe.
- Crimped connector pipe ends must point toward the wood heater flue collar.
- Secure each pipe section to each other and the flue collar using three (3) #10 sheet-metal screws.

MOBILE HOME INSTALLATION:

The Model 1500 has not been safety tested, and is not approved, for installation in Mobile Homes. The design of the Model 1500 does not allow for direct connection of outside air, a HUD requirement for mobile home installation.

* **NOTE:** Installation Illustrations above are informational only. The drawings are not to scale and are not intended to accurately depict construction details nor minimum clearances to combustible materials. Refer to the latest edition of NFPA 211 for current requirements.

MODEL 1500 MASONRY FIREPLACE INSTALLATION

MINIMUM CLEARANCES TO COMBUSTIBLES MEASURED FROM THE FIREPLACE INSERT BODY

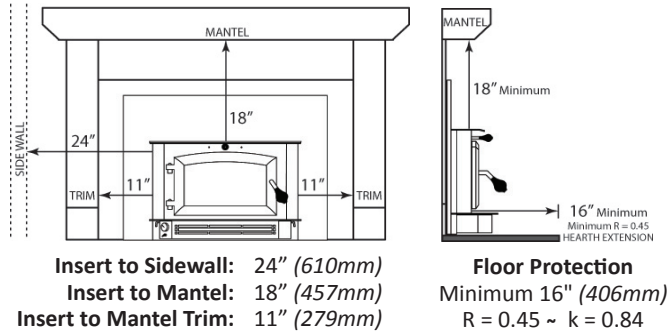

FLOOR PROTECTION:

UL 1618 Type 2 R = 0.45

"3/8" Asbestos Millboard or Equivalent" with k = 0.84

NOTE: Clearances to combustible materials may be reduced using shielding methods as described in the current edition of NFPA 211 Standard for Chimneys, Fireplaces, Vents, and Solid Fuel Burning Appliances. Any reduction of clearances must be approved by the local Authority Having Jurisdiction.

FIREPLACE INSERT INSTALLATION

The fireplace should be inspected before installing a wood burning fireplace insert to confirm that the fireplace is structurally sound and clearances to combustible construction meet all code requirements. Using a certified professional installer who has the specialized knowledge and equipment needed for proper installation is recommended.

- Have the fireplace flue cleaned before installation as needed.
- Clean the fireplace of all ashes and debris before installation.
- Clean creosote deposits from the fireplace chamber. Left-over creosote deposits may produce an odor in the home.
- The fireplace damper plate must be removed or fixed open.
 - Do not modify or damage the damper assembly to facilitate connector installation. Ovalized connector pipe is available to fit through the damper opening and stainless steel damper adapter kits are available to seal the damper opening.
 - Save the damper plate and all parts. If the insert is removed in the future, the fireplace can be returned to working order.
- Use only liner materials listed to appropriate UL standards and carefully follow all instructions provided by the manufacturer.

FULL CONNECTION

The recommended installation method is to connect the fireplace insert to a chimney liner from the insert flue to the top of the chimney. This method ensures a warmer flue and confines all by-products of combustion within the flue liner, simplifying maintenance.

- The liner may be flexible liner or rigid stainless steel pipe.
- The liner should be insulated for better performance and safety.
- A full liner system should be blocked off at or below the damper and sealed against the weather at the top.

DIRECT CONNECTION

The minimum installation requires connection from the insert flue, through the damper and smoke chamber, and well into the first chimney tile liner. Cleaning is more difficult with this type of system.

- The damper opening must be sealed.
- An air-tight cleanout must be provided into the smoke chamber.

Use extreme care when moving the fireplace insert into position. It is very heavy and can cause personal injury or property damage.

- Center the insert in the fireplace opening.
- The insert depth can be adjusted @ 3" to align the flue.
- If the fireplace is not level, or the fireplace floor is below the hearth, leveling bolts (3/8"-16) of the appropriate length (not provided) can be used to level the insert.
- Make good mechanical connection of the liner to the insert and maintain at least minimum clearances to combustible materials.

* **NOTE:** Installation Illustrations on Pages 13 & 14 are informational only. The drawings are not to scale and are not intended to accurately depict construction details nor minimum clearances to combustible materials. Refer to the latest edition of NFPA 211 for current requirements.

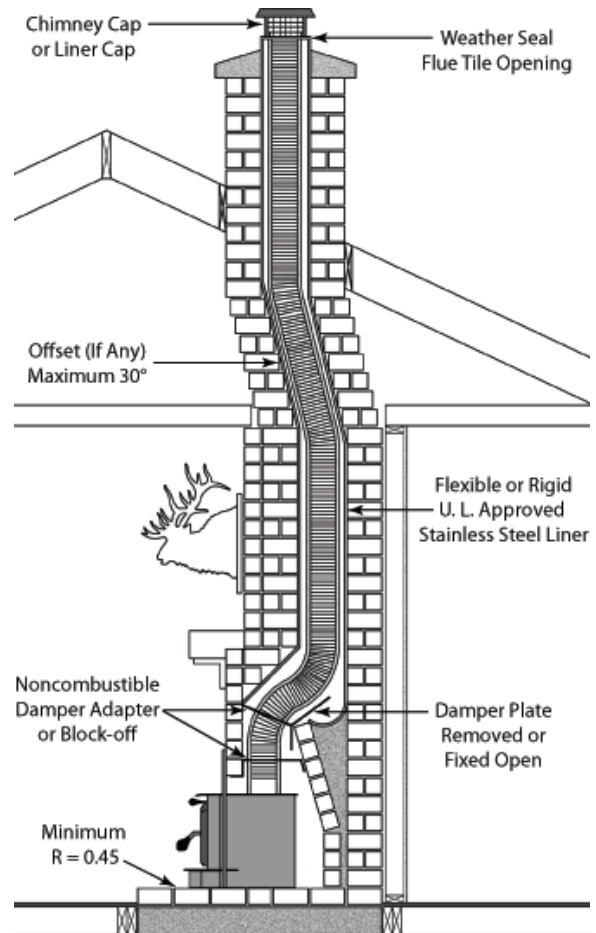

INSERT FULL-CONNECTION INSTALLATION ILLUSTRATION *

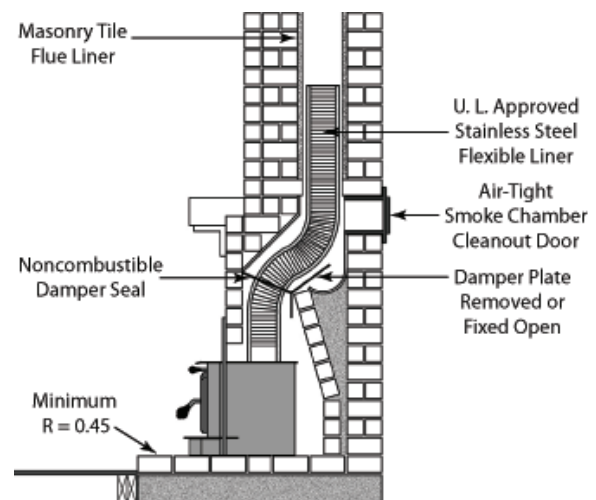

INSERT DIRECT-CONNECTION INSTALLATION ILLUSTRATION *

MODEL 1500 FIREPLACE INSERT DIMENSIONS

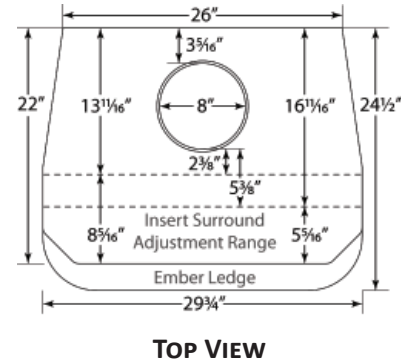
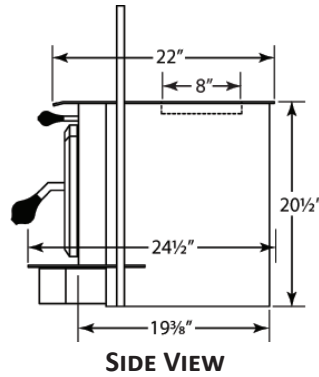
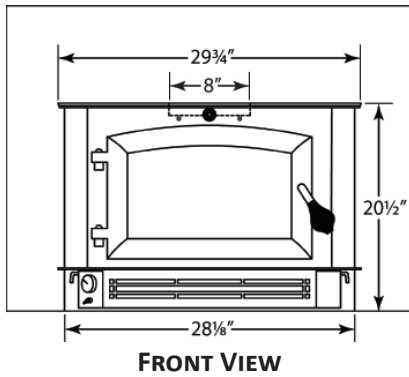

FACTORY-BUILT FIREPLACE INSTALLATION:

The Model 1500 has not been safety tested, and is not approved, for installation into Factory-Built Fireplaces.

FIREPLACE INSERT SURROUND INSTALLATION

After the fireplace insert has been installed into the fireplace, and the liner or direct-connect has been affixed to the insert flue, the Insert Surround can be installed. Ensure that the venting is installed properly and the damper sealed to prevent smoke from entering the home. Verify that all clearances to combustible materials meet or exceed those outlined in the illustration on **Page 13**. It may be advisable to wait to install the Insert Surround until after the installation has been inspected. The building inspector, or other Authority Having Jurisdiction (AHJ), may wish to view the venting and fireplace block-off.

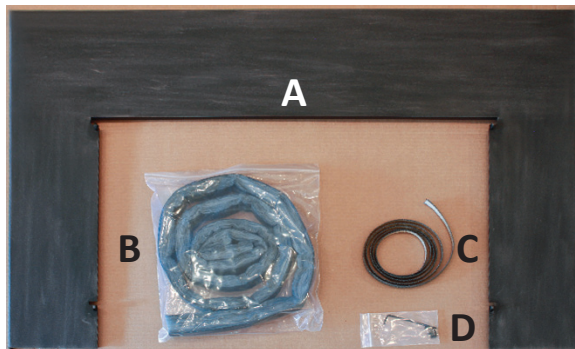

FIREPLACE INSERT SURROUND KIT



FIREPLACE INSERT SURROUND PRESSURE SCREWS

Inspect the contents of the Insert Surround shipping carton for damage and/or missing parts. Contact your High Valley dealer if necessary to report discrepancies. The package should contain:

- A. Insert Surround in the size, style, and color of your choice.
- B. A roll of self-adhesive Fiberglass Insulation..
- C. A roll of self-adhesive Fiberglass gasket material.
- D. Hardware Kit containing 4 cap-screws and a 1/8" Allen wrench.

- Cut three (3) pieces of fiberglass insulation (B) to length to fit the top and sides of the Surround.
 - Remove the paper backing and adhere the insulation to the back of the Surround. (The insulation need not be at the very edges of the Surround, but must frame the fireplace opening.)
- Cut three (3) pieces of gasket material (C) to length to fit the flanges on the inside top and side edges of the Surround.
 - Remove the paper tape and adhere the gasketing to the inside surface of the flanges (facing the insert body).
- Start the four pressure screws into the tabs in the Surround.
 - Do not let the cap-screw threads project through the tabs to prevent marring the insert finish.

Check that the Insert is centered, side to side, in the fireplace opening. The front edge of the Insert top should be no more than 8⁵/₁₆" , and no less than 5⁵/₁₆" , from the face of the fireplace.

- Carefully slide the Insert Surround onto the Fireplace Insert.
 - Do not twist or force the Surround onto the insert. Take care not to mar the Fireplace Insert or Surround finish.
- Hold the Insert Surround firmly against the fireplace face and tighten the four pressure screws evenly. Do not over-tighten.

PRE-OPERATION ADVISORY



CAUTION: HOT WHILE IN OPERATION!

GLASS AND METAL SURFACES ARE VERY HOT WHILE THE WOOD HEATER IS BURNING.

CONTACT MAY CAUSE SKIN BURNS.

KEEP CHILDREN, CLOTHING, FURNITURE, AND FLAMMABLE MATERIALS WELL AWAY.

ENSURE THAT CHILDREN AND ADULTS ARE AWARE OF THE DANGER OF BURNS.

CHILDREN MUST BE CAREFULLY SUPERVISED AT ALL TIMES.

A SAFETY BARRIER SHOULD SURROUND THE WOOD HEATER TO KEEP CHILDREN AWAY.

ALWAYS USE SAFE BURNING PRACTICES:

BURN SOLID WOOD FUEL ONLY.

This wood heater is designed and approved for the burning of cord wood fuel only. Never burn any type of coal in this heater. Burning any type of fuel other than cord wood in this wood heater is against all safety testing and will void all warranties.

DO NOT USE CHEMICALS OR FLUIDS TO START THE FIRE.

Never use gasoline, gasoline-type lantern fuel, kerosene, charcoal lighter fluid, or similar liquids to start or "freshen up" a fire in this wood heater. Keep all such liquids well away from the heater at all times. Storing these or other flammable liquids near a wood heater could cause a fire.

BURN DIRECTLY ON FIREBRICKS.

Do not use grates, andirons, or other methods to support or elevate fuel.

DO NOT OPERATE IN AN EXTREME MANNER AS TO OVER-FIRE THE WOOD HEATER.

If any part of the wood heater, the chimney, or the chimney connector glows, you are over-firing. If over-firing occurs, close all combustion air controls immediately. Over-firing can cause damage to the wood heater and may cause a fire.

NOTICE: Before lighting the wood heater for the first time ensure that any inspection required has been completed and passed by the local Building Inspector, Fire Official, or other Authority Having Jurisdiction (AHJ).

Smoke and CO detectors should be installed on every floor of your home. A smoke detector that is installed in the same room as the wood heater should be located as far away from the wood heater as possible. See **Page 2**. Many states have requirements mandating the installation of smoke and CO detectors. Those regulations must take precedence.

Be sure you have notified your homeowner's insurance company that a wood heater has been installed in your home. Inquire whether they require their own inspection.

It is recommended that a "Type A B C" fire extinguisher be kept in close proximity to the wood heater in the event that hot embers should escape the firebox during the loading of fuel and/or the removal of ashes. Please use all due care when loading or servicing the wood heater.

- **Never throw water on a burning wood heater.**
- Thermal shock could break the ceramic glass, exacerbating the problem.
- Hot steam could increase the risk of burns or scalding.

MODEL 1500 FEATURES & COMPONENTS

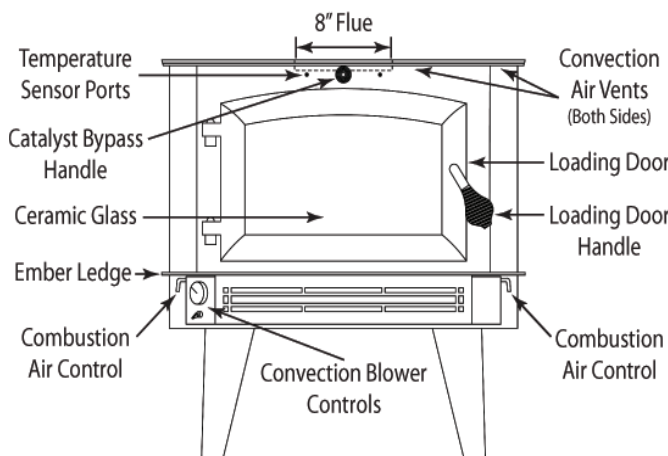

TEMPERATURE SENSOR PORTS: For the Catalytic Monitor.

CATALYTIC BYPASS HANDLE: Pull out to open the bypass for loading; push in to engage the catalytic combustors.

LOADING DOOR: Allows access to the firebox for loading.

CERAMIC GLASS: Ceramic material withstands high temperatures and allows a view of the fire.

DOOR HANDLE: Rotate to latch/unlatch the loading door.

EMBER LEDGE: Designed to catch ash and embers.

COMBUSTION AIR CONTROLS: Regulate the amount of air fed to the fire to adjust the burn rate and temperature. Pull-out to open and push-in to close. Open both controls for start-up and close to adjust the burn rate as desired.

CONVECTION BLOWER CONTROLS: Turn the Convection Blower on and off and adjust the blower speed.

ATTENTION: Your new wood heater has been painted with high temperature (1200°) stove paint. During the first few firings the heater may give off slight smoke, odors and/or vapors while the paint and oils used in manufacturing cure. These odors may be irritating to susceptible individuals. Open the windows in the room where the heater is installed while the paint cures.

ATTENTION: Any tags or stickers must be removed and optional plated loading doors and/or trim must be cleaned with ammonia free glass cleaner and a soft rag BEFORE lighting the wood heater for the first time. Failure to clean the glass or plated finish properly to remove any fingerprints or oils may permanently mar the finish. Never attempt to clean the door finish or door glass when hot.

OPERATION GUIDELINES

CAUTION: Before lighting your catalytic equipped wood heater please read and/or re-read the safety information on **Pages 2, 4 & 15**, and elsewhere throughout this manual. Ensure that the wood heater has been installed according to the instructions given in this manual, to all applicable codes, and has been inspected as required. Always use safe burning and operating practices, and exercise extreme caution when fueling and maintaining the wood heater. Failure to follow these precautions may result in burns or a fire.

LIGHTING A FIRE: Take time to test the draft conditions in the chimney before loading the firebox with kindling.

- Fully open (pull-out) the Bypass Damper & both Combustion Air Controls located under the Ember Ledge.
- Carefully open the Loading Door.
- Crumple one or two pieces of black & white newspaper into a ball, light them at the back of the firebox under the open bypass damper, and close the loading door.
 - If smoke from the burning paper is drawn up the chimney then proceed with building the fire.
 - If smoke has filled the firebox but does not seem to be venting, the chimney may be cold. Warming the chimney may take a few attempts. Open the loading door very slightly and see if extra air helps. **Never** leave the room with the loading door open. Continued operation with the door ajar can cause dangerous overheating and may damage the Catalytic Combustor.
 - In the fall or spring of the year the outside temperature may not be cold enough to establish adequate draft. Wait for a colder day and try again.

NOTE: In a well insulated home draft may be affected negatively. Consult your dealer. See **Page 18**.

- Once draft is established, begin building the fire.
 - Build the fire directly on the firebrick floor. Never use andirons, fire-dogs, grates, etc. to elevate the fire. Use only clean, uncontaminated wood.
 - Traditionally tightly twisted sheets of B&W newsprint are placed at the back of the firebox with dry softwood kindling (½ to 1" diameter) on top, followed by finely split (1½" to 2") dry wood, and then small logs.
 - The "top-down" lighting technique is recommended as an alternative. Simply invert the order of the kindling. Place the layer of small logs across the firebox with the finely split dry wood arranged in a grid on top of the logs and dry kindling wood as the next layer. Alternate the direction of each layer of wood and leave air spaces between the pieces of wood. Use twisted newsprint or catalytic-safe firestarters to ignite the kindling at the **top** of the pile. This method has been found to produce less smoke and emissions during startup.
 - Once the kindling has fully ignited open the Loading Door slowly, and add larger pieces of dry firewood.
 - When the new wood has ignited monitor the Catalytic Combustor temperature and when it reaches activation temperatures, close the Bypass Damper.
 - Control the burn rate using the Air Control Dampers. Actual setting will depend on chimney draft. For a long, slow burn try setting the Air Controls @ 25% open.

FUEL: Always burn dry, well seasoned wood; preferably hardwood. Don't use color newsprint, painted, or pressure treated wood. No other solid or liquid fuels may be used.

STAGES OF COMBUSTION: See **Page 24**.

KINDLING STAGE: During the first stage of combustion keep the Bypass Damper and the Air Controls open to help drive off moisture from the wood load. Wait until the Combustor has reached activation temperatures of 500°F or more before closing the Bypass Damper. The time needed during this stage will depend on the moisture in the wood.

GAS VAPORIZATION & IGNITION STAGE: During the second stage of combustion the Combustor should be activated and the Bypass Damper fully closed. The smoke and volatile gasses burn in the presence of the catalyst at temperatures over 1100°F. Adjust the Air Control openings between 25% and 75% open for the desired burn rate and heat output.

CHARCOAL BURNING: During the final stage of combustion the air can be set to extend burn time. Allow enough combustion air to keep the catalyst activated. This catalytic wood heater has a manufacturer-set minimum low burn rate. **It is against federal regulations to alter this setting.**

CONTINUOUS BURNING: To maintain a continuous fire, fuel must be added while the charcoal bed is hot enough to kindle the fresh wood. Establish a regular routine and develop good habits for operating the wood heater.

- **Always wear heat resistant "woodstove" gloves.** Protect yourself from accidentally touching hot surfaces or ceramic glass when refueling and/or servicing your wood heater.
- **Fully open the Bypass Damper and Air Controls before opening the Loading Door.** Opening both the Bypass Damper and Air Control allows the air pressure in the firebox to equalize with room air pressure and unburned volatile gasses to vent up the chimney.
- **Have fresh cord wood logs ready at hand.** Minimize the amount of time that the Loading Door remains open.
- **Unlatch the Loading Door and pause.** If the draft is weak opening the Loading Door too quickly allows oxygen-rich room air to combine with unburned volatile gasses in the firebox and may cause "back-puffing" or a flash-back.
- **Open the Loading Door slowly.** Pulling the Loading Door open aggressively can pull smoke into the room.
- **Load fresh logs carefully.** Load wood that is cut to the correct length and split to a manageable size into the wood heater with care. Fill the firebox but don't overload it. Don't slam, jam, or force logs into the firebox. Damage to the Firebrick and/or the Catalytic Combustor may result.
- **Close & Latch the Loading Door carefully.** Don't use the Loading Door as a battering ram to force unwieldy logs into the firebox. Damage to the ceramic glass can result.
- **Allow the Catalytic Combustor time to fully activate (500°F to 650°F) before closing the Bypass Damper.** If it is necessary to keep the Loading Door slightly ajar to freshen the fire, **never** leave the room while the door is unlatched.
- **Reset the Air Controls.**

OVER-FIRING: Never operate the wood heater in an extreme manner. If any part of the wood heater, the chimney, or the chimney connector glows, you are over-firing. A chimney with a very good draft may draw in too much combustion air, even with the Air Controls in a closed position. If the fire seems uncontrollable, consult your dealer. A hand damper installed in the connector pipe will allow for manual control under high draft conditions.

OPERATION GUIDELINES

CONVECTION BLOWER OPERATION: A Convection Blower is a standard feature of the Model 1500. The Convection Blower increases the delivery of heated air into the home. The Convection Blower is equipped with a Thermal Switch (snap disk), which turns the blower on as the heater warms up and off as it cools, and a Variable Speed Switch. Additional instructions are on **Page 23**.

- Set the Toggle Switch to "Therm" to allow the snap disk to turn the blower on and off automatically.
- Set the Toggle Switch to "Manual" to bypass the snap disk.
- Rotate the Variable Speed Control clockwise to turn the blower On and increase speed; counterclockwise to reduce speed or to turn the blower Off.
- Match the Convection Blower speed to the burn rate.

CERAMIC GLASS: The Model 1500 is equipped with a clear window which allows monitoring the condition of the fire without the need to open the Loading Door. The transparent ceramic material has been safety tested for impact and thermal resistance, however it can be damaged if it is abused. Inspect the ceramic glass frequently for signs of damage. Never operate the wood heater with damaged, cracked, or broken ceramic glass. See **Page 22**.

Creosote deposits will build up on the window, especially when burning low fires. The deposits may burn off with a hot fire. **Never** use oven cleaners, harsh cleaners containing ammonia, or abrasive cleaners that may cause scratches that can develop into cracks. Harsh chemicals can also permanently damage the catalyst. A simple and cost effective solution is to use damp (not wet) black & white newspaper to remove light staining. To remove heavier deposits, dip the newsprint (or a damp cloth) in a small amount of cold wood ash. Special glass cleaners for woodstoves, formulated to dissolve creosote, are also available. Check that they are labeled as safe for use with catalytic equipped wood heaters.

ASH DISPOSAL: Remove ashes once they get 2" to 3" deep, or deep enough to impede the air inlet located beneath the Loading Door opening. Remove ashes when the fire is extinguished or burned down to embers at the end of the charcoal stage of combustion. Use a steel rake to gather unburned charcoal or embers to one side and leave them in the firebox to be consumed as fuel. Remove spent ash only, leaving @ ½" to 1" of ash and hot coals in the firebox to insulate the ember bed and ignite fresh fuel. Again, try to avoid shoveling up hot coals or embers with the spent ash. Embers can stay hot for days insulated in ashes. Use a steel shovel to carefully remove the spent ashes into a steel container with a tight-fitting lid and move the container outdoors immediately. The closed container of ashes should be placed on a non-combustible surface or on bare ground, well away from any building and all combustible materials, pending final disposal. If the ashes are to be disposed of by burial in soil or otherwise locally dispersed, they should be retained in the closed container until all embers have thoroughly cooled. No other waste of any kind shall be placed in this container.

Some ashes may spill while removing them from the firebox. Ashes can be vacuumed up once they are proved to be completely cool, but be advised that fine ash can pass through the vacuum and into the home. Special vacuums, equipped with heat resistant filters and designed for ash clean-up and removal, are available through your dealer.

SMOKE OPACITY: The amount and density of smoke coming from the chimney is a visual indicator of how cleanly the wood heater is burning. Develop a habit of checking the smoke opacity regularly, and at various stages of combustion. With experience a quick glance can confirm proper operation or signal that something needs attention. Modern catalytic equipped wood heaters can burn wood very cleanly and efficiently but, ultimately, they rely on the operator to engage the Catalytic Combustor at the proper times and to adjust the combustion air properly. Timing and air settings are dependent on the draft of the chimney, the fuel being burned, and the stage of combustion. Ideally you will observe little or no smoke (0% opacity). Dense smoke indicates poor combustion. Be aware that in cold weather what looks like smoke could be moisture vapor condensing in cold air.

CREOSOTE FORMATION & REMOVAL: When wood is burned slowly, it produces tar and other organic vapors which combine with moisture to form creosote. At one time it was popular to install a very large "air-tight" woodstove, load it full of wood, and reduce the combustion air; perfect conditions for producing creosote. Modern catalytic equipped wood heaters, properly operated and maintained, burn off the smoke and creosote that older stoves produced, but the same elements are present. Tars and vapors, combined with moisture, can condense in the chimney at temperatures below @ 250°F. The resulting creosote can accumulate, clinging tightly to the flue liner and, if ignited, can create a very hot and dangerous chimney fire.

Creosote producing tars and vapors are burned at temperatures over 1100°F in the presence of the Catalytic Combustor. The Combustor will consume the smoke and creosote producing tars if it is properly activated and supplied with sufficient combustion air. Even still, in a relatively cool chimney, especially an exterior masonry chimney, the exhaust gasses can cool before they exit the flue and some creosote will be produced. The chimney connector and chimney should be inspected at least once every two months during the heating season, or more frequently as needed, to determine if creosote build-up has occurred. Contact your High Valley dealer or local chimney sweep if you are uncertain how to inspect the venting system. Always have the chimney cleaned at the end of the burning season or before resuming operation.

IN CASE OF A CHIMNEY FIRE: If your wood heater is operated properly to maintain clean, efficient combustion, connected to a good chimney, burning good, dry wood, and inspected regularly, a chimney fire should be an unlikely occurrence. If a chimney fire does occur it can be dangerous and frightening. Chimney fires are often accompanied by a loud rushing sound and, at times, banging noises within the chimney. ***Should a chimney fire occur, alert everyone in the home and leave the building immediately.*** Contact the fire department. If it appears safe to reenter the home close the Air Control and manual damper (if so equipped) wearing a heat resistant glove, to cut off air to the fire. Do not throw water on the wood heater. Thermal shock could break the ceramic glass causing smoke and/or ember spillage, or otherwise damage the wood heater. Have the chimney inspected and cleaned or repaired as necessary before resuming operation of the wood heater.

TROUBLESHOOTING INFORMATION

Wood heater performance issues are most often related to poorly seasoned or wet fuel, poor chimney performance, and/or maintenance. Wood heaters are manually operated and, as such, depend on the operator to follow good burning practices and to use properly seasoned cord wood of the best quality available. With experience the operator will learn to quickly spot changes in performance that may indicate the need for chimney cleaning or other maintenance. Chronic draft or smoke leakage problems should be discussed with your High Valley dealer or a professional chimney sweep and resolved. (Refer to Chimney Performance on **Page 6**.) Use well seasoned hardwood and keep it dry and protected from rain and snow with an appropriate cover. Refer to Appendices A & B on **Pages 24 & 25**.

PROBLEM	POSSIBLE CAUSE	POSSIBLE SOLUTION
THE FIRE IS SLOW TO START OR SMOULDERS.	The Bypass Damper is closed	Open the Bypass Damper fully for starting and loading.
	Air Controls aren't full open	Open (push-in) both Air Controls fully for startup.
	The chimney is cold	Use extra paper or other to warm the chimney before lighting.
	The kindling is not dry	Use enough fully dry softwood kindling to establish a coal bed.
	It is too warm outside	Wait for colder weather before lighting the fire.
	The hand damper is closed	Open the hand damper fully (if so equipped).
	The chimney is obstructed	Have the chimney, connector pipe, and cap cleaned.
THE FIRE IS LAZY, SMOKES EXCESSIVELY, IS SLOW TO IGNITE FULLY, OR DOESN'T HEAT AS EXPECTED.	See all of the above	Use enough kindling to establish a hot fire before loading logs.
	Green or wet wood	Use well seasoned wood that is not wet or covered with snow.
	Bypass Damper closed early	Allow the Catalytic Combustor to activate fully (500°F to 600°F).
	The Air Controls are closed	Allow the fire to become fully established before adjusting.
	Negative house pressure	Open a window. Make-up air supply may be needed.
SMOKE COMES OUT OF THE LOADING DOOR.	The Bypass Damper is closed	Open the Bypass Damper before opening the Loading Door.
	The Air Controls are closed	Open the Air Controls before unlatching the Loading Door.
	Door opened too quickly	Unlatch the Loading Door, pause, then open the door slowly.
SMOKE LEAKAGE WITH BYPASS DAMPER CLOSED.	Bypass Damper closed early	Allow the Catalytic Combustor to activate fully (500°F to 600°F).
	Catalytic obstructed	The Catalytic Combustor elements may need cleaning.
TOO MUCH HEAT; THE FIRE CANNOT BE CONTROLLED PROPERLY.	Too much combustion air	Close the Start-up Air Control and use the Primary Control.
	Loading Door unlatched	Close and latch the Loading Door securely.
	Worn Loading Door gasket	Replace the Loading Door gasket.

SMOKE IN THE HOME: Always operate the wood heater according to the guidelines on **Page 16 & 17**. You must develop and use good wood burning habits; always open the Bypass Damper and Air Controls before opening the Loading Door, and always open the Loading Door slowly to avoid pulling smoke from the firebox into the home. A modern wood heater, properly installed and connected to a good chimney which provides adequate draft, should not leak smoke into the home. Air is drawn **into** the wood heater, and **into** any small gaps in the connector pipe, by negative pressure (draft). If smoke is leaking into the home from the wood heater or the connector pipe there is inadequate draft or the chimney is blocked in some way. A smoke alarm or CO detector sounding will signal smoke leakage, and they should be installed throughout your home. See **Page 2**. A whiff of smoke will also alert you to the fact that there is inadequate draft. By-products of wood combustion contain carbon dioxide, carbon monoxide, tars, water vapor, etc., but the distinctive aroma of wood smoke always accompanies them. If you are smelling wood smoke on a regular basis, not associated with lighting or loading, or your CO detector is activated, **have the problem investigated and addressed**. Carbon Monoxide (CO) is particularly dangerous. Atmospheric conditions, tall structures, wind pressures, etc. can negatively affect draft on occasion, but a system that consistently leaks smoke into the home needs to be corrected. Draft is measured with a manometer, which accurately measures negative pressure in "inches of water column," to eliminate guesswork. The difference of a few hundredths of an inch of water column can spell the difference between poor performance and clean, efficient burning. Your High Valley dealer or a chimney professional, using experience and all of the tools available to them, should be able to diagnose the problem and recommend solutions.

Negative pressure in the home can overcome natural draft and cause smoke leakage. Today's homes are constructed to be much tighter and better insulated than older homes. Those older homes tended to "breathe" as fresh air was drawn in through myriad cracks to replace the air that rose up the chimney. Today well designed homes are equipped with "replacement air" systems to bring fresh air into the home. Without replacement air, tight homes can inhibit chimney draft and the flow of the chimney may be reversed when a vented appliance, such as a kitchen hood or a clothes dryer, is turned on. Tight homes and house pressures are complicated subjects, but they can be analyzed (also with manometers) and corrected. Fresh air may need to be brought into the room with the wood heater to help relieve negative house pressure conditions.

CATALYTIC INFORMATION AND THERMOMETER INSTALLATION

CATALYTIC TECHNOLOGY: The catalytic combustor technology used in the Model 1500 is similar in many ways to the catalytic converters used on automobiles equipped with internal combustion engines. Both use a noble metal catalyst and, in the presence of the catalyst, the by-products of combustion (in this case wood smoke) ignite at lower temperatures than they would normally. Catalytic combustors begin with a base (substrate) of ceramic material. The ceramic is extruded into a honeycomb shape, to maximize the surface area within the combustor, and then fired to make it rigid, durable, and resistant to high temperatures. The hardened substrate is prepared with a porous base coat, to enhance bonding and increase the surface area, and finally a coating of a noble metal catalyst, such as platinum, palladium, or other, is applied. By definition the catalyst is not consumed, and does not undergo any lasting chemical change, in the chemical reaction it increases. Theoretically the noble metal catalyst could last indefinitely. In fact, over time some elements in wood smoke tend to bond to the noble metal, reducing its effectiveness, and friction from smoke and ash gradually wear or "flatten" the catalyst coating.

The useful life of a catalytic combustor is estimated to be @12,000 hours, barring damage from impact or abuse. At that stage the catalyst is expected to be @75% effective. The combustor will take longer to activate or "light off" and there will be a noticeable drop in heat output. The number of years service you can expect from catalytic combustors will depend on where you live and how you use your wood heater. A serious wood burner, living up north, may expect to get three to four years service, while a casual burner in a more temperate climate may get ten years or more. In any climate, the key to maximum combustor life rests with the operator. At the risk of redundancy; burning only well seasoned cord wood is the best advice.

If you are new to catalytic wood heaters, follow the instructions found in this manual and develop good burning habits. It should not take long to develop your wood burning skills. Developing a rhythm for loading fresh fuel and learning the best time to engage the catalyst comes with repetition. In fact, it may be easier for someone who is unfamiliar with wood heaters to develop a routine than an experienced wood burner who has operated other types of wood heaters. The experienced user may need to unlearn, or change, their burning routine or habits. Regardless of experience, rest assured it is not difficult. Burning good, well seasoned cord wood is the main ingredient for success. Never burn painted, contaminated, or pressure treated wood; or any other prohibited materials listed on **Page 2**. Take full advantage of the long burning capability of your catalytic equipped wood heater. A catalytic equipped wood heater works best with a comfortably full load of cord wood in the firebox. (*But don't "jam" the firebox full.*) Allow the catalytic combustors to activate, close the Bypass Damper, set the Combustion Air for a low to medium fire, enjoy the warmth until the fire has burned down to a good bed of coals, and reload.

CATALYTIC THERMOMETER INSTALLATION: A probe style thermometer is provided with the Model 1500. The thermometer is used to monitor the operating temperatures of the catalytic combustor elements. Two mounting or "sampling" holes are provided on the front of the Model 1500, located on either side of the Catalytic Bypass Handle. The choice of which sampling hole to use is personal preference. Either location works equally well. If you tend to operate the Bypass Damper with your right hand, the thermometer may be best located in the left side sampling hole and vice versa. To install the Catalytic Thermometer, pry one of the metal plugs out of the sampling hole of your choice with a flat bladed screwdriver or a similar tool. Install the bushing that is included with the Catalytic Thermometer into the ¼" sampling hole. The bushing should fit snugly into the sampling hole. Insert the Catalytic Thermometer probe fully into the bushing until the thermometer dial rests against the face of the Model 1500. The probe should fit easily into the bushing and should not need to be forced.

Properly positioned, the tip of the thermometer probe is now reading temperatures inside the firebox and within ½" of the catalytic combustors. In this position the Catalytic Thermometer can accurately measure the temperatures being generated by the combustors. Please note that the Catalytic Thermometer is a bimetallic design, not an "instant-read" thermometer. Allow a few minutes for the reading to stabilize. Likewise, the thermometer records temperatures between 0°F and 2000°F on a relatively small scale. The readings are intended to show operating ranges, not minor degree variations.

CATALYTIC THERMOMETER OPERATION: The Catalytic Thermometer is your best indicator of catalytic combustor performance and condition. The catalytic combustors must reach 500°F or more in order for them to activate or "light-off." Be patient; it may take 30 minutes or more to reach these temperatures from a cold start.

- Once thermometer reads between 500°F and 600°F, close the Bypass Damper to engage the catalytic combustors.
- Continue to monitor the thermometer. If the catalytic combustors have activated, the temperature should continue to increase to 1000°F to 1400°F. This is the best and most efficient operating range. Adjust the combustion air accordingly.
- If temperatures are reading 1400°F or more, reduce the combustion air setting to improve efficiency and prevent damage to the combustors and/or the wood heater.

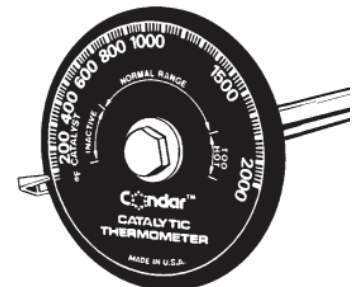

Catalytic Probe Thermometer

DIAGNOSTIC TOOL: The Catalytic Thermometer is a useful diagnostic tool. If you have closed the Catalytic Bypass but the temperature does not continue to rise on the Catalytic Thermometer, the bypass was closed before the combustors were activated. If higher temperatures than normal are needed to activate the catalytic combustors, the combustors may need cleaning or may be reaching the end of their service life. If the catalytic combustors will not "light-off" at any temperature the combustors may be plugged with fly ash or creosote. Follow the instructions on **Page 20** to clean the combustors.

MAINTENANCE: The Catalytic Thermometer requires little or no service. According to the manufacturer, a buildup of material on the probe is normal and does not affect the performance of the thermometer. If you do choose to clean the probe, stove glass cleaner, made for dissolving creosote on ceramic glass, should be used to gently wipe the probe.

CATALYTIC COMBUSTOR REMOVAL & CLEANING

CATALYTIC COMBUSTOR MAINTENANCE: Catalytic combustors should be inspected and cleaned at least annually, whenever the chimney is cleaned, and/or whenever decreased performance is suspected. Whether you perform routine maintenance yourself or rely on a certified professional, regular maintenance ensures maximum efficiency from your wood heater.

CATALYTIC COMBUSTOR HOUSING REMOVAL: Two catalytic combustor elements are fitted into individual cavities in the top of the Combustor Housing. The Combustor Housing is located just inside the Loading Door, secured to the top of the Firebox. The housing assembly is heavy and it is likely to be dusty and/or dirty. Wear a good dust mask and gloves. Handle the Combustor Housing with care. Rough handling or impact can easily damage the catalytic combustor elements.

The Combustor Housing is held in place with four (4) nuts and studs. Two of the nuts are visible on the front edge of the housing; the other two (2) nuts are in the same relative positions on the back of the housing, but are not readily visible. The Combustor Housing is fairly large (4" W x 20" L X 2½" H) and quite heavy. Have a helper support the housing, or cut temporary supports to length from short pieces of 2 x 4, 4 x 4, or similar. The supports should fit loosely under the housing. Do not wedge the housing tightly.

A ratchet, a 9/16" socket, and an extension are recommended for removing the nuts. Loosen the four (4) nuts evenly, but do not remove them until the housing is supported. With the Combustor Housing supported, remove the four (4) nuts. Do not attempt to remove the studs. Lower the housing and remove it from the Firebox. Be aware that the Combustor Housing may contain ashes, soot, and creosote.

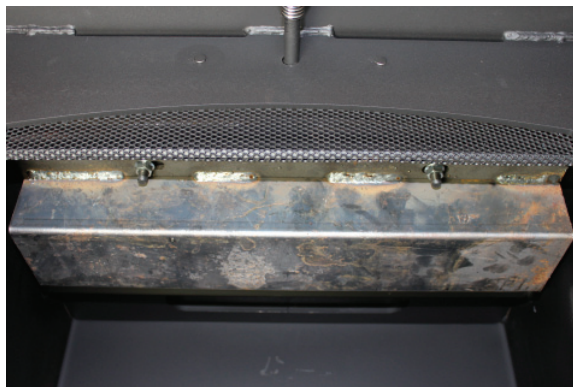

Catalytic Combustor Housing Location

INSPECTION: Handle the Combustor Housing carefully. Remove the housing to a convenient work surface that has been protected with plastic sheeting, newspaper, or the like. Continue to wear a good dust mask and gloves. The top surfaces of the catalytic combustors are now exposed in the housing. Do not tip the housing up-side-down. Do not attempt to remove the combustors from the housing at this stage. Make a careful visual inspection of the catalytic combustors. Ash and soot residue on the combustors is normal and it can be gently removed with a soft paint brush and/or a vacuum cleaner with a soft brush attachment. With the loose ash removed, continue to inspect the catalytic combustor elements. If only normal ash and soot accumulation are observed, finish cleaning the combustors following the instructions below, and replace the Catalytic Housing in the firebox. If any condition other than a normal accumulation of ash residue is observed, refer to the chart below, and additional information on **Page 21**, to help identify and correct the cause of the abnormal condition.

CONDITION	POSSIBLE CAUSE	POSSIBLE SOLUTION
ASH AND SOOT RESIDUE	Some ash & soot are normal by-products of combustion.	Gently remove ash and soot residue with a soft brush or a vacuum with a brush attachment and reinstall the combustors.
COMBUSTOR IS CLOGGED WITH ASH & SOOT	Engaging the Bypass Damper before ashes have settled.	After loading wood or removing ashes, wait for disturbed ashes to settle before closing the By-pass Damper.
COMBUSTOR IS CLOGGED WITH CREOSOTE	The Bypass Damper is closed before the combustors are activated fully.	Always monitor the temperature of the combustors to ensure that the temperature continues to rise after the bypass is closed. Do not try to scrape off creosote. Reinstall the combustors and build a hotter than normal fire. Try engaging the combustors. If the temperature rises, operate at @1400° to burn off deposits.
	Wet or unseasoned wood.	
CRACKING OR CRUMBLING OF THE CERAMIC SUBSTRATE	Thermal shock caused by moisture in fresh wood.	Allow enough time for moisture to be driven off of wet or unseasoned wood before engaging a hot activated catalyst.
	Flame impingement on the catalytic elements.	Do not overfill the firebox or build a roaring fire up close to the Catalytic Combustor Housing.
PEELING OR SCALING	Aggressive cleaning.	Do not use hard tools, stiff brushes, or compressed air to clean the catalyst and do not insert tools into the honeycomb.

CATALYTIC CLEANING: The catalytic combustor elements are held firmly in the Combustor Housing with gaskets that expand when exposed to heat. Unless the combustors are worn out or severely damaged there is no need to remove them. The gaskets lose flexibility after they have expanded and are not reusable. It is not normally necessary to clean the bottom of the catalytic combustors. Vacuum or brush out any ash residue in the bottom of the Combustor Housing. Resist inserting anything into the individual holes in the honeycomb. Even soft tools can damage or remove the catalyst coating. If a few holes are plugged with spent ash that resists vacuuming, clear the holes very carefully with a pipe cleaner as necessary. **Never** insert hard tools, probes, or brushes into the holes in the catalytic combustor. Do not blow out the combustors with compressed air. A powerful stream of air can remove the catalyst coating. In addition, most air compressors are oil lubricated and create condensation in the air tank. Air from a shop air compressor can contaminate the catalyst with oil and/or water. Once the catalytic combustors are cleaned satisfactorily of excess ash and soot, replace the Combustor Housing in the firebox.

CATALYTIC COMBUSTOR DIAGNOSIS, REPLACEMENT & WARRANTY

ABNORMAL CATALYTIC CONDITIONS: Anything more than a coating of wood ash or soot should be considered abnormal. Most of the conditions described below can be corrected or eliminated by using seasoned wood and good burning habits.

- **COMBUSTOR CLOGGED WITH HEAVY ASH ACCUMULATION:** A heavy buildup of ash that plugs the holes in the combustor's honeycomb is indicative of habitually engaging the catalytic before ashes that have been disturbed by loading fresh fuel have settled in the firebox. Allow adequate time for ashes to settle before closing the Bypass Damper.
- **COMBUSTOR CLOGGED WITH CREOSOTE:** Heavy creosote buildup on the combustors is an indicator that the Bypass Damper is too often closed before the Catalytic Combustors are fully activated or "lit-off." Use the Catalytic Thermometer to monitor combustor temperature. Don't close the Bypass until temperatures over 500°F are indicated. If the temperature of the combustors does not continue to rise, reopen the Bypass. Be patient.

Burning unseasoned wood, or wood wet from rain or snow, is an all too common cause of creosote buildup. If you must burn wet or unseasoned wood for some reason, allow plenty of time for the excess moisture to be driven off before closing the Bypass Damper. This may take considerable time. The best advice is to always burn dry, well seasoned wood.

Do not attempt to scrape creosote off the catalytic combustors; damage is sure to occur. Creosote must be burned off the combustors. Because the combustors are coated with creosote, it will take higher than normal temperatures to activate the catalyst. With the Catalytic Thermometer reading @600°F to 650°F close the Bypass Damper. If the temperature does not continue to rise, open the Bypass and allow the catalyst more time to activate. When the catalyst does activate, burn a hotter than normal fire (@1400°F) for an hour or more. Be aware that the necessity to burn off creosote and excessively hot fires will shorten the life of the combustors. Adjust your burning habits to minimize creosote buildup.

- **CRACKING OR CRUMBLING OF THE SUBSTRATE.** Thermal Shock is the primary cause of the ceramic honeycomb substrate cracking or crumbling. Thermal shock occurs when the catalytic combustors are heated or cooled too rapidly. Once again, wet or poorly seasoned wood is most often the culprit. As discussed elsewhere in this manual, moisture must be driven off wet or green wood before the fire can come up to temperature. At best the moisture being driven off as steam is @212°F. The combustor may be 500°F, 600°F, or more. If you close the Bypass Damper before excess moisture is driven off, the relatively cool steam can "shock" and wet the combustor. Allowing the combustor to get excessively hot before closing the Bypass Damper can also cause thermal shock. Using the Catalytic Thermometer to determine when to close the Bypass Damper, and burning well seasoned wood will minimize the chance of thermal shock. Note that a combustor with a crack or cracks may still function unless a section has fallen out of the combustor.

FLAME IMPINGEMENT: Flame impingement occurs when open flame penetrates the catalytic combustors. The Catalytic Combustor Housing is designed to minimize flame impingement by shielding the combustors from open flame. Still, if the firebox is overloaded with wood and a roaring fire is established, strong draft can suck flames into the combustor.

- **PEELING OR SCALING:** Aggressive cleaning with stiff brushes or hard tools can peel the catalytic layer off of the ceramic substrate. High pressure air can have the same effect. Use only soft brushes to clean you combustors.
- **CONTAMINATING THE CATALYST:** Contaminating the catalyst, often referred to as "poisoning," can cause the catalyst to fail temporarily or permanently. Refer to the EPA list of prohibited materials on **Page 2**. Never burn colored newsprint, painted, pressure treated, or chemically treated wood, or any fuel other than clean, well seasoned cord wood.

REPLACEMENT CATALYTIC COMBUSTORS: When your catalytic combustors have reached the end of their service life they must be replaced before the wood heater is put back into service. It is against Federal Regulations to operate your wood heater with the catalytic combustors deactivated or removed. Replacing worn-out or damaged catalytic combustors also makes very good economic sense. Trying to squeeze extra life out of failing combustors can increase your wood consumption by 25% to 50%. With new catalytic combustors you reduce your wood usage, get longer burn times, net more heat into your home from every load of wood, maximize heating efficiency, and minimize your impact on the environment.

Replacement catalytic combustors and heat expanding gaskets are available through your High Valley dealer. If you require assistance or additional information contact High Valley Customer Service or the manufacturer directly. See below.

INSTALLING REPLACEMENT COMBUSTORS: Remove the old combustors. It may be necessary to pry the old combustors out of the Combustor Housing. If the Combustor Housing is warped or damaged, replace the housing.

- Clean any residue from the housing with a scraper and/or a wire brush.
- Install the new catalytic combustors and new gaskets into the Combustor Housing and reinstall the housing in the firebox.
- Handle the Combustor Housing carefully. The combustor elements will be loose in the housing until the gaskets expand with exposure to heat.



CATALYTIC WARRANTY: The High Valley Model 1500 is equipped with catalytic combustors manufactured in the U.S. by Applied Ceramics of Doraville, GA. The Firecat Combustors are covered by a "Limited Lifetime Warranty" by the manufacturer.

- A copy of the warranty and a registration card are included in the materials packaged with your Model 1500.
- Warranty service is handled directly by the Applied Ceramics company at their request. Proof of purchase is required.
- If the Combustor warranty or registration card is missing from your Model 1500, please contact your High Valley dealer or High Valley Stoves customer service. For additional information on Firecat Combustors or warranty service contact:

APPLIED CERAMICS; Customer Service Department; 555 Pleasantdale Road; Doraville, GA 30340
<https://www.firecatcombustors.com> Phone: (770) 448-6888

LOADING DOOR MAINTENANCE & FIREBOX PARTS

CERAMIC GLASS: The Model 1500 Loading Door has a transparent 5mm ceramic window, sealed with a fiberglass gasket, which permits a view of the fire. The ceramic material has excellent heat resistance and strength characteristics, but it can be damaged and/or broken. Cleaning instructions can be found on **Page 17**. Inspect the ceramic glass regularly for signs of damage. Never use cleaners that contain chemicals that can damage the catalytic combustor. Some industry sources advocate the use of a razor blade scraper to remove creosote buildup. If you opt to use this method use extreme care to avoid scratching the ceramic. Monitor any scratches or defects in the ceramic glass as they can develop into cracks with exposure to heat. **Never** operate the wood heater with cracked, damaged, or broken ceramic glass. **Do not** substitute 3 mm ceramic glass, tempered glass, window glass, or similar, under any circumstances. OEM 5mm ceramic glass, cut to size and complete with a new gasket, is available through your High Valley dealer. Part Number: GLS1500

REPLACING CERAMIC GLASS: Damaged ceramic must be replaced before the wood heater can be operated safely. Use care, broken ceramic is sharp! Failure to follow these instructions could result in a fire.

- Remove the Loading Door from the wood heater.
 - Open the Loading Door to @ 90 degrees and lift it straight up.
 - Remove the hinge pins and set them aside.
- Lay the Loading Door face down on a well padded work surface.
 - Allow the Door Handle to hang over the edge of the table.
 - Remove the eight (8) screws and retainer clips.
 - Wearing gloves, remove any remaining pieces of ceramic.
- Place the replacement ceramic glass on a clean section of the padded work area.
 - Remove a short section of the paper backing that covers the gasket adhesive.
 - Center the gasket material on the edge of the replacement ceramic glass and press the gasket onto the ceramic.
 - Continue around all four sides of the ceramic.
 - Trim off any excess gasket with sharp scissors.
- Carefully set the gasketed ceramic glass into the opening.
 - Replace all glass retainers leaving the screws loose.
 - Using a crossing pattern tighten the screws in small increments.
 - The goal is to have all of the screws tightened evenly.
 - The screws should be snug but not overly tight.
- Replace the Loading Door and hinge pins removed earlier.

CAUTION: Creating pressure points with one or more overly tight screws can pinch the ceramic glass and cause it to crack or shatter.

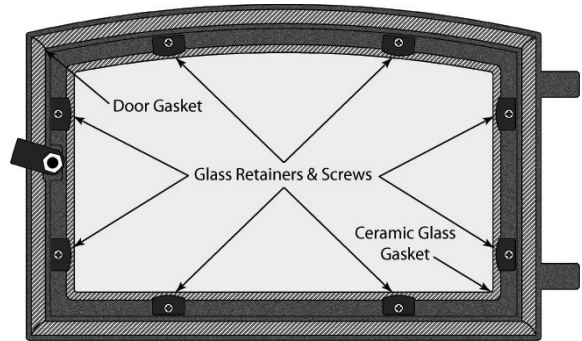

Model 1500 Glass Retainer Locations

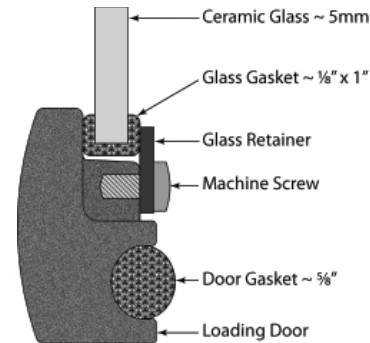

Model 1500 Loading Door Components

DOOR GASKETING: The Loading Door is equipped with 3/8" fiberglass rope gasket. Check the condition of the gasket on a regular basis for signs of wear. Over time the gasket will compress and the door may not seal tightly. Replace as necessary. Use the "dollar bill test" to check the Loading Door seal. With the wood heater completely cooled, insert a dollar bill between the door gasket and the face of the wood heater. Leave half of the bill sticking out, close and latch the door, and tug on the bill. If the bill slips out easily the gasket needs to be replaced. Repeat the test around the perimeter of the Loading Door.

A gasket kit is available from your High Valley dealer and includes silicone adhesive. Part Number: GSKDOR. Thoroughly remove all of the old silicone from the Loading Door before installing the new gasket. Silicone will not adhere to old silicone.

FIREBRICK: The floor of the firebox of the Model 1500 is lined with Firebrick for durability. The fire is burned directly on the Firebricks. **Never** burn the Model 1500 without a complete set of Firebricks installed. If one or more of the Firebricks need replacement, use the illustration at right as a guide to the correct layout when reinstalling the Firebricks.

The Model 1500 uses the following firebrick sizes:

- A: 4 1/2" W x 9" L x 1" H
- B: 4 1/2" W x 4 1/2" L x 1" H

A complete set of replacement Firebricks (P/N FIRBRK1500) is available through your High Valley dealer.

A	A	A
A	A	A
A	B	A

If Firebrick (s) must be removed for any reason, handle with care to avoid breakage. **NOTE:** A Firebrick on the floor of the Firebox which has a simple crack, and is not crumbling, does not necessarily need replacement.

Before replacing the Firebrick (s), clean the firebox thoroughly to ensure that the Firebrick (s) lay flat and fit together properly. The firebox can be swept or vacuumed once it is completely cool. Be aware that fine ash can pass through the filter of a household vacuum or shop vacuum and into the home. Special vacuums, equipped with heat resistant filters designed for fine ash clean-up and removal, are available through your dealer.

CONVECTION BLOWER MAINTENANCE & PARTS

MODEL 1500 CONVECTION BLOWER: A Convection Blower is standard on the Model 1500. The blower is installed and wired at the factory. The Convection Blower is equipped with a Variable Speed Switch, a Thermostatic Switch (also known as a Thermal-disk or Snap-disk) to turn the blower on and off automatically based on temperature, and a Toggle Switch that allows the operator to choose between automatic and manual on/off control.

POWER CORD: The Power Cord is pre-wired to exit the left side of the Convection Blower Cover. The Power Cord can be rerouted to exit on the right side of the Cover if a power outlet is more readily available on the right side of the installation. If you are uncomfortable moving the Power Cord, request that your dealer perform this step for you.

POWER OUTAGES: In the event of a power outage you may wish to use your Model 1500 as a primary heat source. If the power outage is anticipated to last more than a very short time, it is recommended that the Convection Blower be removed to allow natural convection to flow around the wood heater and deliver heated air. Continuing to use the heater with an inoperative Convection Blower may damage or shorten the life of the blower motor. **Unplug the power cord** and follow the directions below to remove the Convection Blower temporarily. Use caution when disconnecting wiring and handling the blower cover.

BLOWER WIRING: If the Convection Blower is to be disconnected for service or replacement, use the wiring diagram at right to ensure that the wiring is reconnected correctly to the blower and components.

REMOVING THE CONVECTION BLOWER COVER: **Unplug the power cord** before removing the blower cover. Use a 3/8" socket, nut driver, or wrench to remove the two (2) bolts securing the Convection Blower Cover. **Support the cover while removing the bolts.** Wiring is attached to the switches mounted on the cover. Swing the blower cover out of the way temporarily, or unplug the switch wiring to remove the cover.

SERVICE & PARTS: If the blower, thermal-disk, or a switch, fails to operate properly, contact your High Valley dealer for service or to obtain OEM replacement parts. Do not operate the Model 1500 for extended periods with an inoperative Convection Blower.

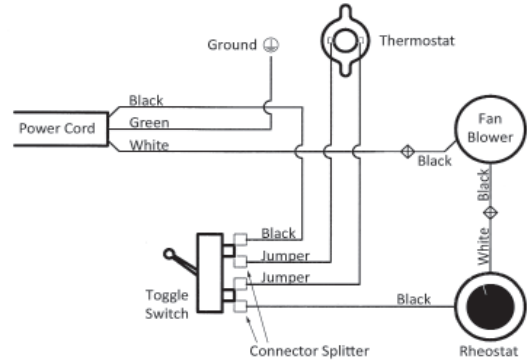

MODEL 1500 BLOWER WIRING DIAGRAM

CONVECTION BLOWER MAINTENANCE: The Convection Blower motor and bearings do not require lubrication. Adding additional lubricant will attract dust and may shorten the life of the motor. Check the blower impeller at least annually (more often as necessary) for any build-up of household dust, pet hair, or the like. Some buildup is normal and will reduce air flow through the impeller. With the **power cord unplugged** vacuum the blower impeller using a brush attachment. It may be necessary to remove the blower using a 3/8" socket, nut driver, or wrench. To make cleaning easier, unplug the two blower motor wires from the switch wiring. A soft brush, such as an old paint brush or toothbrush, can be used to reach dust buildup inside the impeller. Take care to not dislodge balancing weights (if any) from the impeller. Reinstall the Convection Blower and tighten the bolts securely. Reconnect the motor wires and reinstall the cover. Tighten the bolts securely to minimize vibration.

STOVE PAINT: Your High Valley wood heater has been painted with high temperature stove paint at the factory. Over time the paint may lighten in color with heat exposure or need touch-up. Stove Bright brand #1900 Satin Black spray paint is compatible with the standard black OEM paint. If you chose an optional Burnished finish contact your dealer for touch-up paint.

It is no doubt impractical to move the wood heater outside for painting. Open windows and doors for good ventilation before applying paint indoors. Protect all exposed surfaces and furnishings with drop cloths and/or plastic sheeting. Mask any areas not to be painted, including trim and ceramic glass. Apply light coats and follow all instructions and precautions on the spray can. Allow the stove paint to dry thoroughly before lighting a fire. The fresh high-temperature paint produces an acrid odor as it cures which may be irritating to susceptible individuals. Open windows and doors as needed for good ventilation during the curing process. If you are at all uncomfortable with painting indoors, contact your dealer for advice or assistance.

PARTS: Use only OEM replacement parts or approved supplies. A partial list of replacements parts is included below. Contact your High Valley dealer or High Valley Stoves customer service for additional information about replacement parts.

MODEL 1500 REPLACEMENT PARTS LIST

Part Number	Nomenclature	Part Number	Nomenclature
CATPRO	Catalytic Probe Thermometer	BLO1500	Blower, 75 CFM, Model 1500
CATUNI	Catalytic Element, Model 1500 (2 required)	SWIRHEO	Switch, Rheostat, Blower Speed Control
CATHOU	Catalytic Housing, Model 1500	SWITHERM	Switch, Thermal-Disk, 110°F-On / 90°F-Off
GSKCAT	Gasket for 2 Catalytic Elements (approx. 4 ft.)	SWITOG	Switch, Toggle, Blower On/Off
GLS1500	Glass, Ceramic with Gasket, Model 1500	POWCOR	Power Cord, Blower, All Models
GLSHAR	Retainer Clips & Screws for Ceramic Glass	FLUCOL-8	Flue Collar, 8", Model 1500
GSKGLS	Gasket, Fiberglass Tape, Glass, 1/8" x 1"	FLUCOL-86	Flue Collar, 8" to 6" Reducer, Model 1500
GSKDOR	Gasket, Door, 5/8" with RTV Silicone	HANDOR	Door Handle (spring not included)
FIRBRK	Firebrick, Replacement (individual brick)	SPRBYP	Spring, Catalytic Bypass Handle, Painted
FIRBRK1500	Firebrick Set, Complete, Model 1500	SPRDOR	Spring, Door Handle, Painted
PAINTSTOVE	Paint, Spray Can, Hi-Temp, Black		

APPENDIX A ~ BASICS OF WOOD COMBUSTION

Before lighting the first fire in your new wood heater, please read the following information outlining the basic elements of clean wood combustion. Space is limited here, but much has been written on the subject and is available elsewhere.

THE COMBUSTION TRIANGLE: Air, Fuel, and Heat (Ignition) are required to establish and support combustion whether wood, coal, wood pellets, gas, oil, etc. is the fuel being burned. The correct proportion of air and fuel will vary, but the three basic ingredients are essentially the same.

IGNITION: Ignition in a wood heater is straightforward. Typically it involves a match, paper, and kindling wood. Enough heat must be generated and sustained to get the cord wood burning (@ 350°C to 500°C**). For comparison matches are estimated to burn at 600°C to 800°C; a standard butane lighter is somewhat hotter at @ 800°C to 1100°C, paper will ignite at @225°C to 250°C and dry soft wood kindling at @350°C. You light the paper with a match to ignite the kindling and, finally, the cord wood.

NOTE: There are any number of "firestarters" on the market. They light easily with a match and eliminate the need for newspaper. Look for clean burning firestarters that are approved for use with catalytic combustors. **Never use any flammable liquid (s) to start or "freshen" the fire.**

FUEL: The Model 1500 is designed and approved for use with solid natural wood. Use of any other fuel may create excessive emissions and will void the warranty.

The cord wood that you will burn depends to a large degree on what species of trees are abundant where you live. Transporting hardwood from its source to an area where hardwood is scarce would be cost prohibitive. If you live where only softwood species are available, then that is what you will likely use for fuel. In fact all cord wood, regardless of species, has approximately the same potential BTU's* in each pound of wood. A pound of softwood has the same potential @ 8600 BTU's (kiln dry) per pound as a pound of hardwood. "Hardwood" is denser than "softwood", varies in specific gravity, and is therefore heavier by volume; and, of course, wood is sold by volume, not by the pound. A cord of hardwood will take up the same space as a cord of softwood but it will be heavier and contain more potential BTU's.

NOTE: The common unit for the sale or purchase of firewood is the cord. One cord equals 128 cubic feet (4' high x 4' wide x 8' long). Because cord wood is irregularly shaped it would be impossible to achieve a solid 128 cu. ft. block of wood. Wood is supposed to be "well stacked" in a proper cord but that is a subjective measure. 85% wood and 15% air space is commonly accepted as the proper ratio but some sources cite 70% wood and 30% air space. That represents significant difference of @ 109 cu. ft. to @ 90 cu. ft. of usable wood.

Along with density, the other major variable in wood fuel is moisture content. Unseasoned or "Green" wood will contain 50% water or more. Good "air-dried" cord wood is about 20% moisture. At 20% moisture the available BTU's will be @ 6200 to 7000 per pound not 8600. At 50% moisture "green" wood will have only @ 4000 BTU's per pound or less. It follows that cord wood needs to be well seasoned. It may take 9 months for soft woods and up to 24 months for hard woods to air dry thoroughly.

CONCLUSION: Clean, efficient combustion in your wood heater depends on burning well seasoned, good quality fuel. Buying "seasoned" wood in the burning season is expensive and often disappointing. The best advice is to get "green" wood in early spring and air dry it yourself. If you don't cut your own wood, find a reputable, reliable wood seller. Well seasoned wood typically exhibits dark cut ends with radial cracks, but splitting a "dry" log and testing it with a meter eliminates speculation. Home moisture meters have become affordable and readily available. Follow the instructions that come with the meter. Stack your wood off the ground in a well ventilated area, preferably under cover or with a tarp over the top of the stack. More information on wood and wood species see Appendix - B on **Page 25**.

AIR: The other leg of the combustion triangle is air. The air needed to support combustion is drawn into the firebox by the draft of your chimney. See **Page 6**. Final air delivery and metering required much research and engineering to ensure clean combustion but, the good news is, you regulate the combustion air with basic push-pull controls. As long as your chimney drafts well, air control is simplified. It is against federal regulations to alter the air control settings or controls in any way.

STAGES OF COMBUSTION: Put the three elements of the Combustion Triangle together in your wood heater and you will have started a fire. The chemical and physical processes taking place in that fire are complex, and scientific papers on the subject are lengthy and detailed. Three major stages are worth noting and will help the operator understand how to achieve the cleanest burning fire.

STAGE ONE: Kindling & Moisture Evaporation:

Kindling the fire has been covered above under Ignition. Provide enough heat to the wood for a long enough time and it will begin to burn. Before the fire can reach full heating potential moisture in the wood must be evaporated. This is why dry fuel is so important. More than 1000 BTU of potential heat will be needed to drive off each pound of water. Until the water present in the wood is boiled off the fire will be relatively cool, heat from the coal bed will be used up, and flue gas temperatures will be reduced. Burning green wood wastes a lot of energy.

STAGE TWO: Gas Vaporization & Ignition:

After moisture is driven off, the temperature of the fire builds and various hydrocarbons and other elements begin to vaporize. At temperatures of 500°F or more the Catalytic Combustor will activate or "light-off." The Combustor is fueled by the volatile gasses which will ignite at lower temperatures in the presence of the catalyst. Temperatures in the range of 1100°F to 1400°F are achieved and more heat is released to heat the home.

STAGE THREE: Charcoal Burning:

After flammable gasses have been burned off, only charcoal remains. Charcoal burns cleanly at @ 1100°F in the presence of oxygen. Adjust the Air Control as needed to extend the fire. If a continuous fire is desired, add fresh fuel while the charcoal bed is still hot enough to kindle the new wood.

*A British Thermal Unit (BTU) is a measure of the amount of energy (heat) required to raise one pound of water by 1°F at sea level.

**The temperatures are given in Celsius and the temperature ranges are approximate as the values vary from source to source.

APPENDICES B & C

APPENDIX B ~ HEATING VALUES OF WOOD: Natural cord wood does not come with a specification sheet like the building materials described in Appendix C. Manufactured products can be made to strict, repeatable tolerances. Natural wood, on the other hand, varies considerably depending on where it grows, the climate, the mineral composition of the soil, and more. Even still, considerable research and scientific data is available on different varieties of wood. Added to the variations in the wood itself is the fact that fire wood is sold by volume; most typically by the cord. As discussed in Appendix A, a cord measures 4' wide X 4' high X 8' long or 128 cubic feet. Beyond those basic facts it gets less scientific.

The amount of burnable wood that will be available in a given cord can vary greatly on how it is cut, whether it is split, the sizes of the whole or split logs, and the skill (or perhaps the integrity) of the person stacking the wood. A bit of country wisdom avers that well stacked wood will have spaces large enough for a mouse to crawl through but not large enough for the cat chasing him. Well stacked wood should be @ 85% wood and 15% air space. The air spaces are necessary to ensure proper drying. There is some debate among experienced wood burners whether the bark side of split logs should be up (to shed water) or down (to promote evaporation). Bark up or down the wood must be well seasoned (@ 20% moisture) to be considered good firewood. Burning green wood is inefficient and disappointing; cutting the BTU values given below approximately in half.

Below is an abbreviated chart that gives some approximate weight and BTU values for various species of wood. More comprehensive lists are available on line, but a word or two of caution. The statistics can vary widely depending on the source or, more likely, on the point they are trying to make. The numbers can be easily manipulated by changing assumptions. If a cord of wood is assumed to have 30% air space then the estimated available BTU's will be considerably less. Likewise, assuming that a pound of wood at 20% moisture contains say 8000 available BTU will net an appealing, inaccurate number. In researching data we found the variations considerable.

Use the numbers below as a point of comparison between species available to you, not as a score card. The best advice is to find an honest wood vendor and rely on them to deliver a full cord of the best wood available. Buy your wood well ahead of the burning season, dry it well and keep it dry, and enjoy clean efficient wood heat.

WOOD SPECIES	LBS. PER CORD	BTU PER CORD
American Elm	@ 3000 lbs.	@ 20,000,000
Apple	@ 3800 lbs.	@ 27,000,000
Cherry	@ 2925 lbs.	@ 20,500,000
Hemlock	@ 2700 lbs.	@ 18,000,000
Hickory	@ 4200 lbs.	@ 27,000,000
Red Oak	@ 3500 lbs.	@ 24,500,000
Shagbark Hickory	@ 4325 lbs.	@ 27,500,000
Sugar Maple	@ 3750 lbs.	@ 24,000,000
Tamarack	@ 3250 lbs.	@ 21,000,000
White Ash	@ 3500 lbs.	@ 24,000,000
White Birch	@ 3200 lbs.	@ 20,000,000
White Cedar	@ 1915 lbs.	@ 12,500,000
White Oak	@ 4200 lbs.	@ 29,000,000
White Pine	@ 2250 lbs.	@ 15,000,000
Willow	@ 2100 lbs.	@ 14,500,000

All values are approximate and for comparison only.

APPENDIX C ~ FLOOR & WALL PROTECTION: UL Standard 1618; the Standard for Wall Protectors, Floor Protectors, and Hearth Extensions, was adopted as a standard in 2011. UL-1618 categorizes floor and wall protectors as Type 1 or Type 2 protection. A seemingly minor change in UL 1618 calls for the actual thermal properties of floor protection to be specified in R-value in place of k-value. In fact, that change makes it one step simpler to calculate thermal protection if it becomes necessary.

- Type 1: Ember Protection = No thermal value
- Type 2: Thermal Protection = R-value specified

Type 1 Ember Protection is deemed to be a continuous non-combustible material extending under the appliance and to the front, sides, and back in the size specified. Any thermal value a Type 1 protector may have is disregarded under UL-1618. Type 2 Thermal Protection provides thermal resistance in addition to ember protection. Thermal value is determined by laboratory test. UL-1618 calls for thermal requirements to be expressed as R-values rather than as k-values which were used in the past.

If a hearth or floor protection is to be built on-site, or there is an existing hearth already in place, then the thermal resistance must be calculated. This is where having thermal requirements expressed as an R-value vs. k-value simplifies calculations. R-values can be added together.

- R-value is a unit of measure of Thermal Resistance. It is commonly known as the measure of insulation value. As with insulation, the higher the number, the better.
- k-value is a unit of measure of Thermal Conductivity. k-value is the opposite (inverse) of R-value in that the smaller the k-value the greater the resistance.

Where R-values for different materials can be added together to determine the total R-value of composite layers of materials, k-values cannot. Converting k-value to R-value is relatively simple but it frequently causes confusion. (It should be noted that there are other units of measure, such as C-value, Thermal Conductance, but they are not as commonly used in hearth applications.) So, again, if only the k-value is given, then it must be converted to R-value. (Keep in mind that the k-value is given per inch of material.) To convert k-value to R-value divide 1 by the k-value of the material and *divide by the thickness of the material*. C-values can also be converted to R-values ($1 \div C\text{-value}$) and R-values can also be converted to k-value ($\text{inches} \div R$) but by staying with R-values materials can be added together.

Floor protection requirements were once commonly expressed as "3/8" of asbestos millboard $k = 0.84$ " or similar. The conversion is: $1 \div 0.84 = 1.19 \times 0.375" = 0.45$ R-value.

With the R-values known, consider this example:

A wood heater requires $R = 1.19$. If 4" common brick is the material of choice; their R-value is 0.80 (0.20 X 4"). Add 1/2" of Durock ($R = 0.26$) and the protection is still not adequate ($R = 1.06$). Add one more layer of 1/2" Durock and the floor protection is now acceptable ($R = 1.32$). (Brick, tile, etc. must be mortared in place, not loose laid.)

MATERIAL	R-VALUE	k-VALUE
Common Brick	$R = 0.20$ per inch	$k = 5.00$ per inch
Durock	$R = 0.52$ per inch	$k = 1.92$ per inch
Hardibacker	$R = 0.51$ per inch	$k = 1.95$ per inch
Micore 160	$R = 2.86$ per inch	$k = 0.86$ per inch
Marble	$R = @0.09$ per "	$k = @11$ per inch

More complete lists of material specifications and more detailed explanations of calculations can be found online.

WARRANTY COVERAGE

High Valley Stoves by Stoll warrants its High Valley brand wood heaters to be free from defects in material or workmanship, under normal use and conditions of service, to the original purchaser, for a period of seven (7) years from the date of purchase subject to the following limitations: Electrical Components (blowers, switches, etc.) are warranted against mechanical and electrical failures, under normal use and conditions of service, to the original purchaser for a period of one (1) year. High temperature ceramic glass is warranted to be free from defects in material, under normal use and conditions of service, to the original purchaser for a period of one (1) year. Damage to glass caused by impact is considered abuse and is not covered under this warranty. Catalytic Combustors are warranted by the manufacturer for a period of five (5) years. The warranty is administered by the manufacturer of catalytic combustors directly. The original purchaser should register the purchase of any High Valley wood heater equipped with a catalytic combustor with the manufacturer within 30 days of purchase using the warranty registration provided by the manufacturer of the catalytic combustor. Terms and exclusions of warranty on catalytic combustors are established by the manufacturer of the catalytic combustor and not by High Valley Stoves by Stoll. The following items are not covered under warranty: Gaskets, Paint, Damper, Damper Handles and Rod, Fireclay Bricks or castable lining, and all parts not permanently attached to the heating unit. Parts not permanently attached to the heating unit are defined as any part removable with common hand tools. If, after installation, assemblies and/or components covered under this warranty are found to be defective in materials or workmanship during the warranty period, High Valley Stoves by Stoll will, at its option, repair or replace the covered components, subject to the limitations set forth in this warranty.

HIGH VALLEY STOVES LIMITED WARRANTY CONDITIONS: This warranty is nontransferable and is extended exclusively for the benefit of the original purchaser, provided that the appliance purchase was made through an authorized High Valley dealer. The wood heater should be used within 30 days of purchase by having a fire started, the blower operated, and heat generated in the owner's home to confirm proper operation of all components. The product must be installed, operated, and maintained in compliance with the instructions set forth in the Owner's Manual supplied with the product at all times. Installation, setup, and start-up procedures are considered to be normal required activities not associated with warranty service. Issues such as adjustments or venting should be included in setup of the product. Such procedures are not covered by warranty. Any installation, construction, transportation, or other related costs or expenses arising from defective part(s), repair, replacement etc., will not be covered by this warranty, nor will High Valley Stoves by Stoll assume responsibility for them. Further, High Valley Stoves by Stoll will not be responsible for any incidental, indirect, or consequential damages. This warranty constitutes the entire warranty with respect to High Valley Stoves by Stoll and/or its products. High Valley Stoves by Stoll makes no other warranty, expressed or implied, including any warranty of merchantability, or warranty of fitness for a particular purpose.

EXCLUSIONS AND LIMITATIONS: This warranty does not cover the following: Damage caused by transportation and/or handling of the product; damage due to incorrect installation not in accordance with the Installation Instructions included with the product and any applicable national, state, and local building and fire codes, etc.; [High Valley appliances must be installed by a qualified (preferably NFI certified) installer. It is the installer's responsibility to ensure that the product is installed and operating correctly at the time of installation. Chimney components and/or other non-High Valley accessories used in conjunction with the installation of this product are not covered under this warranty.] Damage caused by improper use, which is not in accordance with the Instructions for Use and Maintenance included with the product (over firing, use of corrosive fuel, etc.); Damage caused by unauthorized modification, use, or repair; Damage caused by the use of non-High Valley spare parts or accessories; Damage caused by lack of regular maintenance and cleaning by the owner as outlined in the Operating Instructions, or due to negligence or carelessness; Damage caused by misuse, accident, neglect, or willful abuse of the product; Damage caused by the use of any type of coal in any High Valley wood heater. (The use of seasoned wood is required.); Damage due to accidental or uncontrollable environmental causes such as: intense cold, fire, lightning, voltage overload or drop, inadequate venting or ventilation, negative air pressures cause by mechanical systems such as furnaces, fans, clothes dryers, etc., and Damage due to wiring or mechanical systems not in accordance with applicable national, state, and local codes; Damage caused by rust or corrosion due to condensation, dampness, humidity, or incorrect installation; Calls for warranty service that are determined to be occasioned by lack of maintenance or factors not related to the High Valley appliance; Normal wear and tear such as paint discoloration, abrasion, worn gaskets, etc.; Repair or replacement of wear-parts which are subject to normal wear and tear during the warranty period, or parts that may require replacement in connection with normal maintenance; The installation of consumer replaceable items and installation of upgraded components; Noise resulting from the movement of motorized parts or minor expansion and contraction which is considered normal, not a defect.

THIS WARRANTY IS VOID IF: The appliance has been over-fired. Over-firing can be identified by, but not limited to, warped firebox components, discolored cast iron, discolored, bubbled, or cracked painted finishes; The appliance has been used to burn coal of any type; the appliance is subjected to prolonged periods of dampness or condensation; There is any damage to the appliance or other components due to water or weather damage which is the result of, but not limited to, improper chimney or venting installation.

LIMITATIONS OF LIABILITY: The exclusive remedy of the owner, and High Valley Stoves by Stoll's sole obligation under this warranty, and under any other warranty, express or implied, or in contract, tort or otherwise, shall be limited to repair or replacement as specified above. High Valley Stoves by Stoll assumes no liability for incidental damages or damages of any kind which may arise from the use of its products. In no event will High Valley Stoves by Stoll be held liable for any incidental, indirect, or consequential damages caused by defects in its products. The maximum amount recoverable under this warranty is limited to the purchase price of the product. This Warranty provides specific legal rights and the consumer may have other rights that vary from state to state. Some states do not allow exclusions or limitation of incidental or consequential damages, so these limitations may not apply to you. Except to the extent provided by law, High Valley Stoves by Stoll makes no express warranties on its High Valley Stoves other than the warranty specified herein. The duration of any implied warranty is limited to duration of the expressed warranty specified above.

IF WARRANTY SERVICE IS REQUIRED: If, during the warranty period, a High Valley wood heater is proved to be defective in material or workmanship, High Valley Stoves by Stoll will, at its own option, repair or replace the product as described below. Any claim for warranty service should be made to the dealer from whom this High Valley wood heater was purchased. Confer with your dealer in advance to determine any additional costs associated with a warranty service call. Service charges and/or mileage are not covered under warranty. These charges vary from retailer to retailer. Your authorized High Valley dealer will procure replacement parts and/or contact High Valley Stoves by Stoll to arrange for replacement should the appliance exhibit defects in material and workmanship which are beyond field repair. Extraordinary repairs which are deemed to require replacement must be approved by High Valley Stoves by Stoll prior to said repair or replacement. Any removal fees, transportation costs, reinstallation fees, construction costs, or any other related costs or expenses arising from replacement will not be covered by this warranty, nor will High Valley Stoves by Stoll assume responsibility for them.

OWNER'S RECORD & SAFETY LABEL

High Valley Model: **1500** Serial Number: _____
 High Valley Dealer: _____ Date of Purchase: _____
 Installed by: _____ Installation Date: _____
 Inspected by: _____ Date of Inspection: _____



CAUTION

HOT WHILE IN OPERATION. DO NOT TOUCH. CONTACT MAY CAUSE SKIN BURNS. KEEP CHILDREN AND CLOTHING AWAY. KEEP FURNISHINGS AND OTHER COMBUSTIBLE MATERIALS FAR AWAY FROM THE APPLIANCE. SEE NAMEPLATE AND INSTRUCTION MANUAL.

SAFETY WARNINGS

PREVENT CREOSOTE FIRE: Inspect the chimney connector and chimney twice monthly and clean as necessary. Under certain conditions creosote buildup may occur rapidly.

DO NOT OVER-FIRE: If the wood heater or chimney connector glow, you are over-firing.

OPERATE WITH DOOR CLOSED. Immediately replace any damaged door glass with Ceramic Type Stove Glass only.

DO NOT USE GRATE OR ELEVATE FIRE. Build wood fire directly on firebox floor.

DANGER! Risk of Electrical Shock. Disconnect power before servicing unit. (Standard Blower: 115V | .62FLA | 3000 RPM)

U.S. ENVIRONMENTAL PROTECTION AGENCY

Certified to comply with 2015 particulate emission standards.
 Not approved for sale after May 15, 2020.

FOR USE WITH SOLID WOOD FUEL ONLY.

DO NOT use any other solid or liquid fuel. Use of other fuels may damage the heater and create a dangerous condition.

This wood heater contains a catalytic combustor, which needs periodic inspection and replacement for proper operation. It is against federal regulations to operate this wood heater in a manner inconsistent with operating instructions in this manual, or if the catalytic element is deactivated or removed.

This wood heater needs periodic inspection and repair for proper operation. Consult the owner's manual for further information.

PREVENT HOUSE FIRES

Install and use only in accordance with the manufacturer's Installation and Operating Instructions. Contact your local Building or Fire Officials or other Authority Having Jurisdiction about code requirements, restrictions, and installation inspections in your area.

CHIMNEY & CONNECTOR: Use eight inch (8 in.) (203 mm) diameter minimum 24 MSG black steel connector pipe with a UL 103 HT and/or ULC629 listed factory-built "Class A" chimney suitable for use with solid fuels or a masonry chimney. Special methods are required when passing a chimney through a combustible wall, ceiling, or roof. Single wall connector pipe requires 24" clearance to vertical walls and/or horizontal ceilings. Do not pass chimney connector through a combustible wall or ceiling. See manufacturer's instructions and local buildings codes. Do not connect this solid fuel appliance to a chimney flue serving another appliance.

MINIMUM CLEARANCES TO COMBUSTIBLES MEASURED FROM THE WOOD HEATER BODY

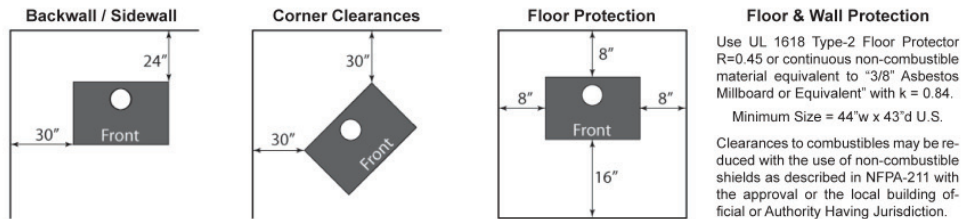

Fireplace Insert Installation Clearances

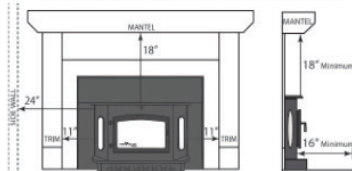

Model 1500 insert is for use in a masonry fireplace which meets all codes. High Valley Model 1500 has not been tested or approved for installation into mobile homes.

Model 1500 has not been tested or approved for installation into a zero-clearance factory built fireplace. High Valley Model 1500 has not been tested or approved for installation into an alcove.

High Valley Model 1500 insert is approved for installation into a High Valley 1500-ZC Zero-Clearance cabinet when a masonry fireplace is not available. High Valley Model 1500 has not been tested or approved to Canadian Standards for installation in Canada.

Fireplace hearth must provide thermal protection of R = 0.45 (k = 0.84) and must extend a minimum of 16 inches (16") in front of the fireplace insert face.



MODEL: **1500**

FUEL: **WOOD**

SERIAL #:

Manufactured by:
HIGH VALLEY STOVES by **STOLL**
 185 Highway 201, Abbeville, SC 29620

Tested by:
CONAM Inspection, Inc. - AGTL | Natick, MA 01760
 Tested 3/1988 to ANSI/UL 1482

DATE OF MANUFACTURE:

						2015	2016	2017	2018	2019	2020
JAN	FEB	MAR	APR	MAY	JUN	○	○	○	○	○	○
○	○	○	○	○	○	○	○	○	○	○	○

DO NOT REMOVE THIS LABEL

This facsimile of the Safety Label, which is attached to the back of your Model 1500, is provided for the convenience of the owner, the Authority Having Jurisdiction, or any other inspector, who wishes to verify the contents of the label. In some installations the label is not easily accessible. Please record the serial number off the original label for your records.

